

PFE01 壓腳提昇裝置 PFE01 Presser Foot Lifter

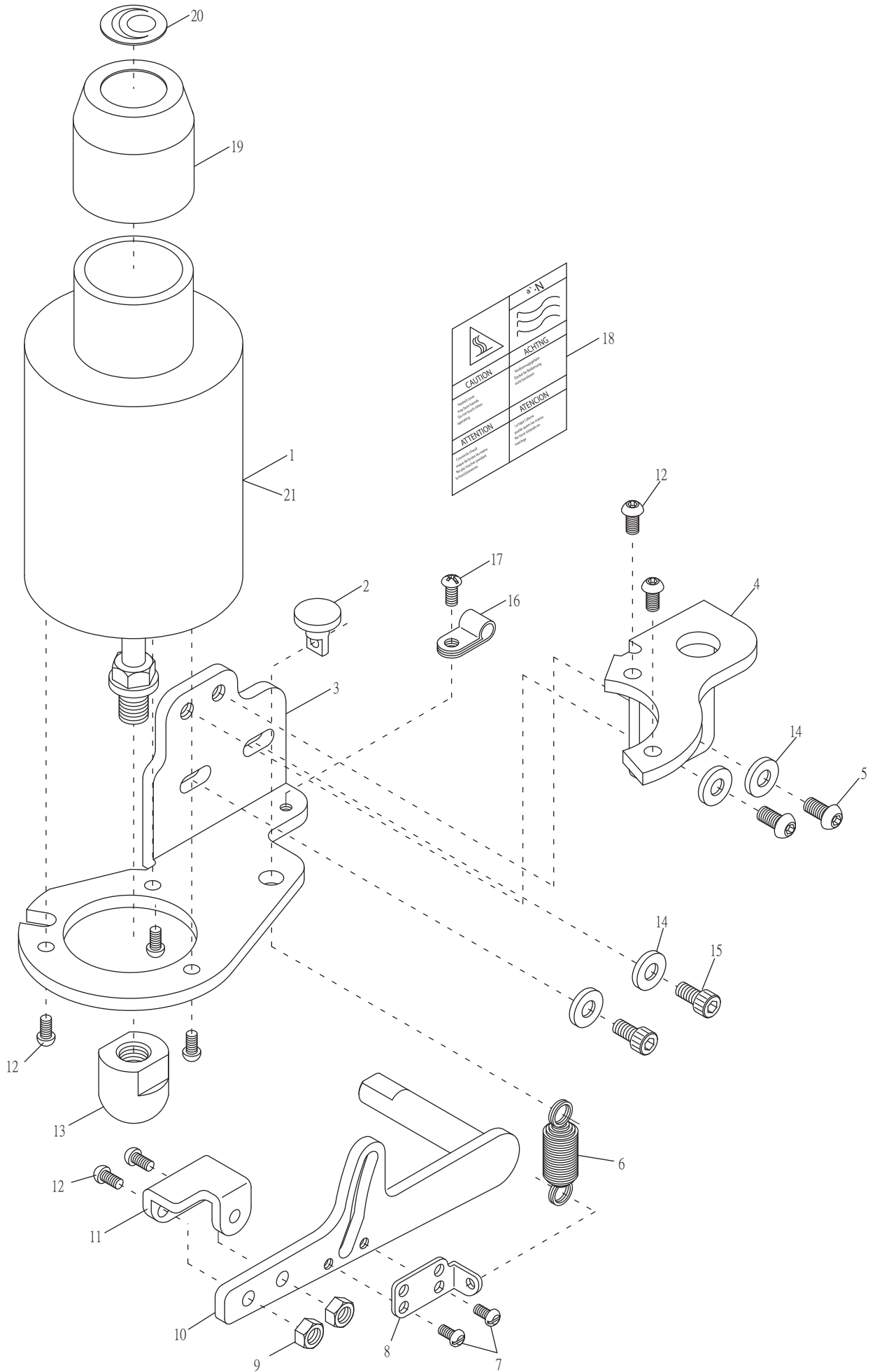

PFE01 壓腳提昇裝置 PFE01 Presser Foot Lifter

序號	物料編號	名稱	單位用量
Ref. No.	Parts Number	Description	Amt. Req.
1	4PFE0101011	磁力線圈 Presser Foot Lifter Solenoid -----	1
2	4PFE010102	接頭 Joint -----	1
3	4PFE0101031	固定座 Bracket -----	1
4	4PFE010104	固定座 Bracket -----	1
5	8MP06401211A	螺絲 Screw (CT0302 M6-1*12) -----	2
6	4PFE010106	彈簧 Spring -----	1
7	8MB85240607K	螺絲 Screw (CT0637 M3.5-0.6*6) -----	2
8	4PFE010108	固定座 Bracket -----	1
9	8MA05320408A	螺帽 Nut (CT1028 M5-0.8*4) -----	2
10	4UTC000108	揚昇臂 Lifter Arm -----	1
11	4UTC000109	輔助板 Supplementary Plate -----	1
12	8MP05321210A	螺絲 Screw (UTB0340 M5-0.8*11.5) -----	7
13	4PFE010113	套管 Clutch Sleeve -----	1
14	2100000323	墊圈 Washer(SH0323) -----	4
15	8MM06401610A	螺絲 Screw (CT0625 M6-1*16) -----	2
16	4UTD000254	線夾 Cord Clamp -----	1
17	8MC04280807A	螺絲 Screw (CT0130 M4-0.7*8) -----	1
18	4UTC000139	貼紙 Paster -----	1
19	4PFE010119	護蓋 Cover -----	1
20	66480-11	銘板 Plate -----	1
*21	4PFE1P0121	磁力線圈 Presser Foot Lifter Solenoid -----	1

* PFE1P 用(用於切線+RP之機型)