

4. UTC01電控式組件 UTC01 Electric Type Components

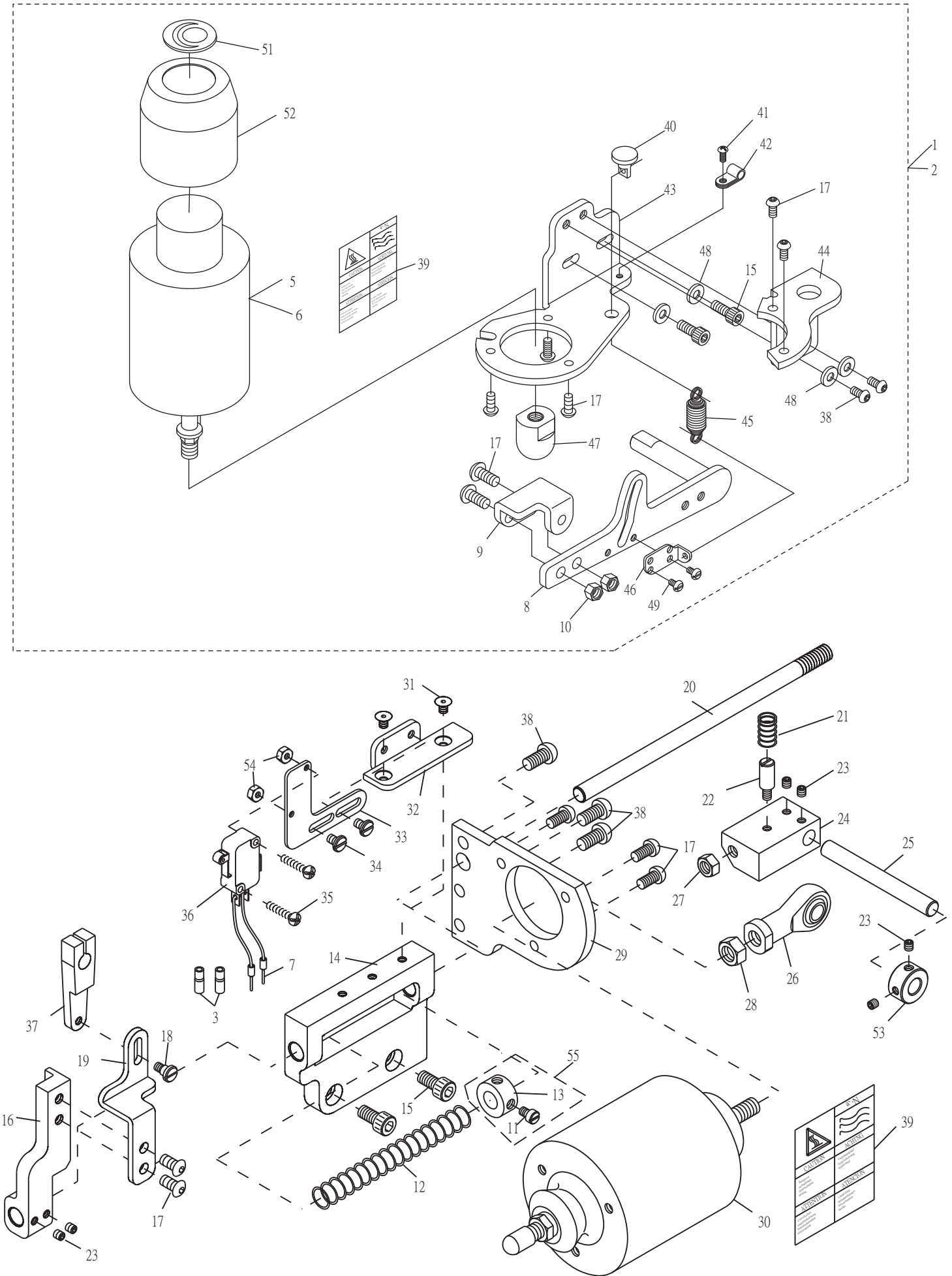

4.UTC01電控式組件 UTC01 Electric Type Components

序號 Ref. No.	物料編號 Parts Number	名稱 Description	單位用量 Amt. Req.
1	PFE01	壓腳提昇組 Presser Foot Lifter,C.Set -----	1
*2	PFE1P	壓腳提昇組 Presser Foot Lifter,C.Set -----	1
3	4UTB020228	絕緣套管 Bushing -----	2
4	-----	-----	-
5	4PFE010101	磁力線圈 Presser Foot Lifter Solenoid -----	1
*6	4PFE1P0121	磁力線圈 Presser Foot Lifter Solenoid -----	1
7	4UTB020272	公端子 Power cord -----	2
8	4UTC000108	揚昇臂 Lifter Arm -----	1
9	4UTC000109	輔助板 Supplementary Plate -----	1
10	8MA05320408A	螺帽 Nut (CT1028 M5-0.8*4)-----	2
11	8MC95300606F	螺絲 Screw (CT0823 M4.5-0.75*5.5)-----	1
12	4UTC000112	彈簧 Spring -----	1
13	4UTB010245	定位環 Collar -----	1
14	4UTB000342	空壓組件座 Trimming Cylinder Support -----	1
15	8MM06401610A	螺絲 Screw (CT0625 M6-1*16)-----	4
16	4UTB000341	連桿 Connecting Block -----	1
17	8MP05321210A	螺絲 Screw (UTB0340 M5-0.8*11.5)-----	12
18	8MB04280908G	螺樁 Stud (UTB0339 M4-0.7*4)-----	1
19	4UTB010338	連桿 Connecting Plate -----	1
20	4UTB010328	軸 Shaft -----	1
21	4UTB000321	彈簧 Spring -----	1
22	8MB04280707M	螺樁 Stud (FT0122 M4-0.7*7)-----	1
23	8MN04280400A	螺絲 Screw (CT0229 M4-0.7*4)-----	6
24	4UTB010324	承座 Plunger -----	1
25	4UTC0001251	軸 Shaft -----	1
26	4UTC000126	球軸連桿 Plunger Connecting Rod -----	1
27	8MA08500513A	螺帽 Nut (FTC10126 M8-1.25*5) -----	1
28	8MA08500613A	螺帽 Nut (RP10208 M8-1.25*6)-----	1
29	4UTC0001291	磁力線圈座 Solenoid Barcket -----	1
30	4UTC0001301	磁力線圈 Solenoid -----	1
31	8MQ04280808A	螺絲 Screw (UTB0109 M4-0.7*8)-----	2
32	4UTC000132	基板 Base -----	1
33	4UTB000333	安全開關座 Safety Switch Bracket -----	1
34	8MB04280608A	螺絲 Screw (UTB0130 M4-0.7*6)-----	2
35	8MC03201606D	螺絲 Screw (UTB03351 M3-0.5*16) -----	2
36	4UTB000336	安全開關 Safety Switch -----	1
37	4UTB010337	曲柄 Tension Release Lever -----	1
38	8MP06401211A	螺絲 Screw (UTB0302 M6-1*12)-----	5
39	4UTC000139	貼紙 Paster -----	2
40	4PFE010102	接頭 Joint -----	1
41	8MC04280807A	螺絲 Screw (CT0120 M4-0.7*8)-----	1
42	4UTD000254	線夾 Cord Clamp -----	1
43	4PFE0101031	磁力線圈固定座 Bracket -----	1
44	4PFE010104	固定座 Bracket -----	1
45	4PFE010106	彈簧 Spring -----	1
46	4PFE010108	固定座 Bracket -----	1
47	4PFE010113	套管 Clutch Sleeve -----	1
48	2100000323	墊圈 Washer (SH0323) -----	4
49	8MB85240607K	螺絲 Screw (CT0637 M3.5-0.6*6) -----	2
50	-----	-----	-
51	66480-11	銘板 Name Plate -----	1
52	4PFE010119	護蓋 Cover -----	1
53	4UTB010152	定位環 Collar -----	1
54	8MA03200306A	螺帽 Nut (FTB0111 M3-0.5*3) -----	2
55	4UTB01A0255	定位環組 Collar Asm-----	1

* 配合RP使用