

5. UTC01 鬆線機構及更換零件 UTC01 Thread Tension Components And Motor Components

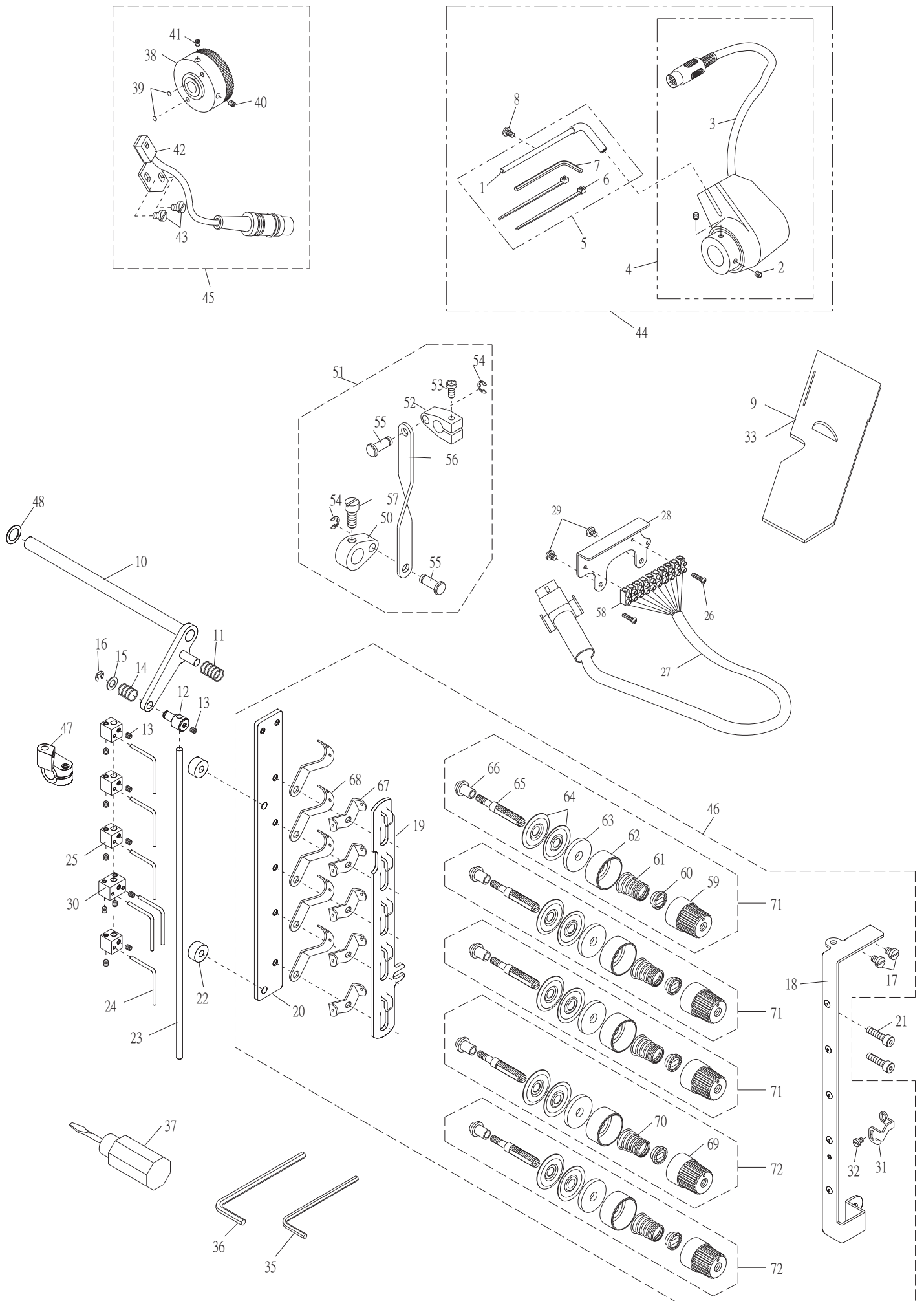

5.UTC01 鬆線機構及更換零件 UTC01 Thread Tension Components And Motor Components

| 序號 Ref. No. | 物料編號 Parts Number | 名稱 Description | 單位用量 Amt.Req. |
|----------------|----------------------|--|------------------|
| 1 | 4UTB020308 | 止動桿 Stopper ----- | 1 |
| 2 | 8MN06400600A | 螺絲 Screw (CT0244 M6-1*6) ----- | 2 |
| 3 | 4UTB020303 | 針定位器 Synchronizer ----- | 1 |
| 4 | 4UTB02A0304 | 針定位器組 Mount- on Type Synchronizer ----- | 1 |
| 5 | 4UTB02A0305 | 止動桿組 Stopper Set Asm. ----- | 1 |
| 6 | 4UTB020306 | 束線 Plastic Binding Wire ----- | 2 |
| 7 | 4UTB020307 | 六角扳手 Allen Key ----- | 1 |
| 8 | 8MC04281007A | 螺絲 Screw (CT0113 M4-0.7*10) ----- | 1 |
| *9 | 4UTB010409 | 防塵蓋 Dust Cover ----- | 1 |
| 10 | 4UTB000410 | 曲柄 Tension Release Shaft ----- | 1 |
| 11 | 4UTB000411 | 彈簧 Spring ----- | 1 |
| 12 | 4UTB000412 | 接頭 Pin ----- | 1 |
| 13 | 8MN03200300A | 螺絲 Screw (CT0115 M3-0.5*3) ----- | (see the table) |
| 14 | 4UTB000414 | 彈簧 Spring ----- | 1 |
| 15 | 2200001025 | 墊圈 Washer ----- | 1 |
| 16 | 90ER030 | E 形扣環 E Ring ----- | 1 |
| 17 | 8MB04280507K | 螺絲 Screw (FT0235 M4-0.7*5) ----- | 2 |
| 18 | 4UTB000418 | 導線 Thread Guide Eyelet----- | 1 |
| 19 | 4UTB000419 | 鬆線滑板 Release Wedge ----- | 1 |
| 20 | 4UTB000420 | 導線座 Tension Post Support ----- | 1 |
| 21 | 8MN04281607A | 螺絲 Screw (CT0724 M4-0.7*16)----- | 2 |
| 22 | 4UTB000422 | 隔環 Spacer ----- | 2 |
| 23 | 4UTB000423 | 導桿 Guide Bar ----- | 1 |
| 24 | 4UTB000424 | 鬆線桿 Release Bar ----- | (see the table) |
| 25 | 4UTB000425 | 鬆線座 Thread Pull-off Block ----- | (see the table) |
| 26 | 8MC03201006D | 螺絲 Screw (UTB0426 M3-0.5*10)----- | 2 |
| 27 | 4UTB000427 | 換向閥用控制線 Terminal Holder ----- | 1 |
| 28 | 4UTB000428 | 端子座固定架 Termianl Holder Support ----- | 1 |
| 29 | 8MB04280608A | 螺絲 Screw (UTB0130 M4-0.7*6)----- | 2 |
| 30 | 4UTB000434 | 鬆線座 Thread Pull-off Block ----- | (see the table) |
| 31 | 4UTB000435 | 導線 Thread Guide Eyelet----- | 1 |
| 32 | 8MB03200306X | 螺絲 Screw (UTB0436 M3-0.5*3) ----- | 1 |
| **33 | 4UTB010433 | 防塵蓋 Dust Cover ----- | 1 |
| 34 | ----- | ----- | - |
| 35 | 66635 | 六角扳手 Allen Key 2MM ----- | 1 |
| 36 | 66640 | 六角扳手 Allen Key 2.5MM ----- | 1 |
| 37 | 66668 | 平口起子 Screwdriver ----- | 1 |
| 38 | 4UTB000443 | 手輪 Handwheel ----- | 1 |
| 39 | 4UTB000444 | 磁鐵 Magnet ----- | 2 |
| 40 | 8MN06400800A | 螺絲 Screw (CT0549 M6-1*8) ----- | 1 |
| 41 | 8MN06401100C | 螺絲 Screw (CT0548 M6-1*11) ----- | 1 |
| 42 | 4UTB00447 | 內藏式定位器 Build-in Type Synchronizer ----- | 1 |
| 43 | 8MB04280608A | 螺絲 Screw (UTB0130 M4-0.7*6) ----- | 2 |
| ***44 | 4UTB02A0347 | 外置式定位器組 Mount- on Type Synchronizer Set----- | 1 |
| ***45 | /BS001 | 內藏式定位組 Built-in Type Synchronizer ----- | 1 |
| 46 | 4UTB00A0452 | 鬆線組 Thread Tension Mechanism ----- | 1 |
| 47 | 4UTB000451 | 結線鉤座 Looper Holder ----- | 1 |
| 48 | 4UTB010459 | 墊片 Clamp Spring Pressure Holder ----- | 1 |
| 49 | ----- | ----- | - |
| 50 | 4UTC010250 | 連桿 Lever ----- | 1 |

5. UTC01 鬆線機構及更換零件 UTC01 Thread Tension Components And Motor Components

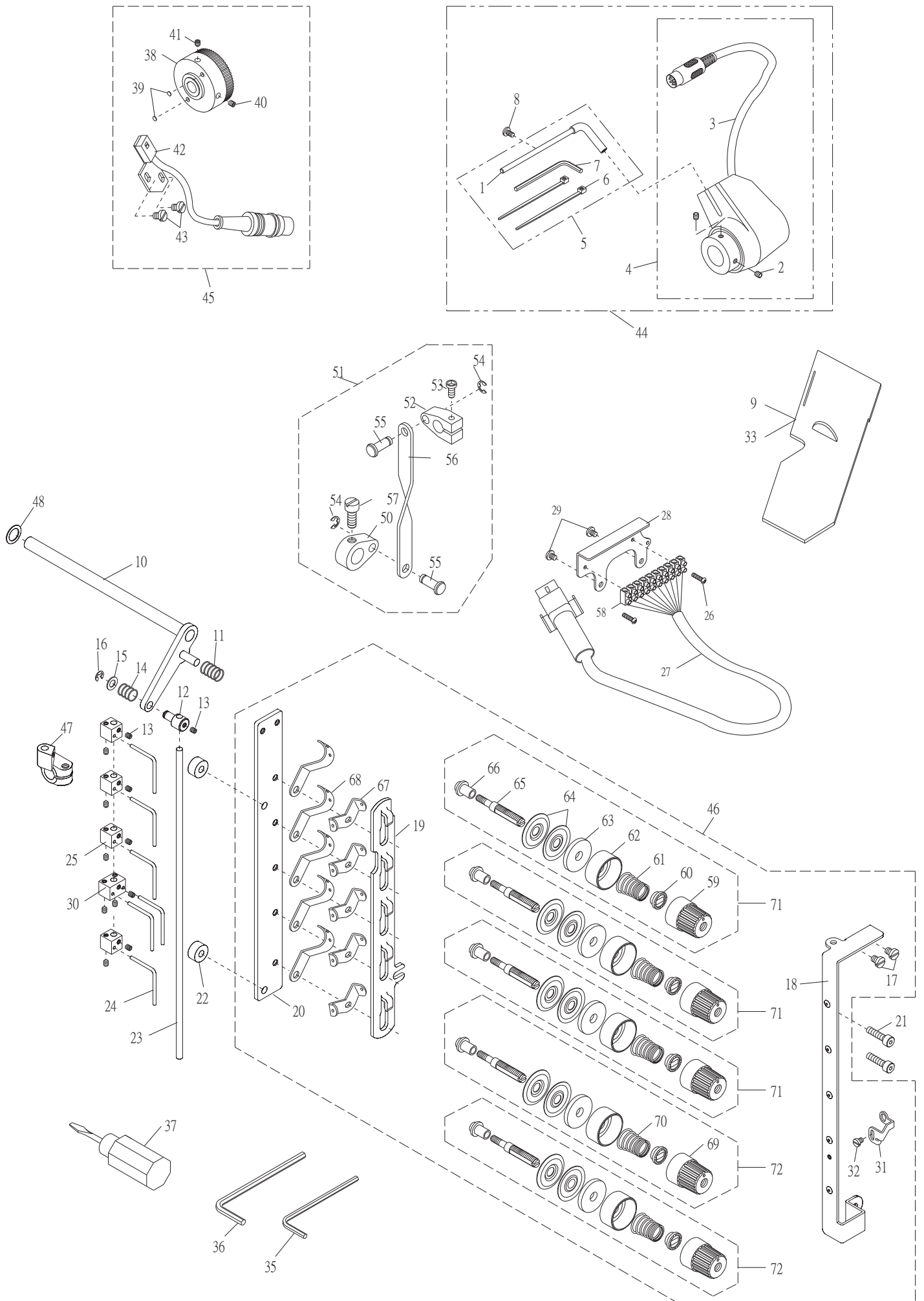

5.UTC01 鬆線機構及更換零件 UTC01 Thread Tension Components And Motor Components

| 序號 Ref. No. | 物料編號 Parts Number | 名稱 Description | 單位用量 Amt.Req. |
|----------------|----------------------|---|------------------|
| 51 | 4UTC01A0251 | 連桿組 Link Asm. ----- | 1 |
| 52 | 2200000826 | 連桿 Lever ----- | 1 |
| 53 | 8MM05321409A | 螺絲 Screw (CT0632 M5-0.8*14) ----- | 1 |
| 54 | 90ER030 | E形扣環 E Ring ----- | 2 |
| 55 | 2200000829 | 連結銷 Connecting Pin ----- | 2 |
| 56 | 2200000830 | 連桿 Link ----- | 1 |
| 57 | 8MC06401008E | 螺絲 Screw (CT0832 M6-1*10) ----- | 1 |
| 58 | 4UTB000457 | 控制線接頭 Connector----- | 1 |
| 59 | 2100001121 | 張力調整螺帽 Tension Nut (Red) (SH1121) ----- | 3 |
| 60 | 2200000303 | 套管 Bushing ----- | 5 |
| 61 | 2100001123 | 彈簧 Spring (Red) (SH1123) ----- | 3 |
| 62 | 2200000305 | 彈簧座 Spring Seat ----- | 5 |
| 63 | 2100001127 | 羊毛氈 Felt ----- | 5 |
| 64 | 2100001126 | 張力控制盤 Tension Disc ----- | 10 |
| 65 | 22000003081 | 螺樁 Stud ----- | 5 |
| 66 | 22000003091 | 隔環 Spacer ----- | 5 |
| 67 | 2200000311 | 導線 Thread Guide ----- | 5 |
| 68 | 2200000312 | 導線 Thread Guide ----- | 5 |
| 69 | 2100001121A | 張力調整螺帽 Tension Nut (Yellow) (SH1121) ----- | 2 |
| 70 | 2100041131 | 彈簧 Spring (Yellow) (SH1131) ----- | 2 |
| 71 | 231A0001922 | 張力控制組 Tension Asm. (Red) ----- | 3 |
| 72 | 220A0000315 | 張力控制組 Tension Asm. (Yellow) ----- | 2 |

| Ref. No. | 13 | 24 | 25 | 31 |
|---------------------------|--------|-------|-------|-------|
| 2 Needle without Spreader | 7pcs. | 3pcs. | 3pcs. | |
| 3 Needle without Spreader | 9pcs. | 4pcs. | 4pcs. | |
| 2 Needle with Spreader | 10pcs. | 5pcs. | 3pcs. | 1pcs. |
| 3 Needle with Spreader | 12pcs. | 6pcs. | 4pcs. | 1pcs. |

*: 40M,48M,56M用 For 40M,48M,56M

** : 64M用 For 64M

***: 選購,並須配合伺服馬達使用 <型號HVP-60,HVP-70,HVP-90>

****: To choose and purchase: These two devices should be used together with AC servo motor
<Model No:HVP-60,HVP-70,HVP-90>