



5. UTC03 / UTC07 電控式組件 Electric Type Components For UTC03 / UTC07

序號 Ref.No.	圖號 Parts No.	名稱 Description	單位用量 Amt .Req.
1	4UTC040201	磁力線圈 Solenoid -----	1
2	4UTC040202	球軸連桿 Plunger Connecting Rod -----	1
3	4UTC0201031	承座 Plunger -----	1
4	4UTC040204	連桿 Connecting Plate -----	1
5	4UTC0201091	彈簧 Spring -----	1
6	4UTC040206	軸 Shaft -----	1
7	4UTC040207	承座 Plunger -----	1
8	8MC04280807A	螺絲 Screw (CT0120 M4-0.7*8) -----	1
9	8MB05320710G	螺絲 Screw (PFE020116 M5-0.8*7) -----	1
10	4UTC0201101	承座 Plunger -----	1
11	4UTC0201111	連桿 Connecting Plate -----	1
12	66480-11	銘板 Plate -----	1
13	4UTC0201131	基板 Base -----	1
14	4UTC0201141	安全開關座 Saftey Switch Bracket -----	1
15	8MM05321409A	螺絲 Screw (CT0632 M5-0.8*14) -----	1
16	4PFE010119	護蓋 Cover -----	1
17	4UTC020171	線夾 Cord Clamp -----	1
18	8MA03200306A	螺帽 Nut (FTB0111 M3-0.5*3) -----	2
19	8MP05321210A	螺絲 Screw (UTB0340 M5-0.8*11.5) -----	5
20	4UTB010152	定位環 Collar -----	1
21	4UTC020121	曲柄 Tension Release Lever -----	1
22	8MB04280908G	螺樁 Stud (UTB0339 M4-0.7*4) -----	1
23	8MB04280507K	螺絲 Screw (FT0235 M4-0.7*5) -----	4
24	8MP05320810A	螺絲 Screw (STB0117 M5-0.8*8) -----	2
25	8MN04280400A	螺絲 Screw (CT0229 M4-0.7*4) -----	4
26	8MP06401211A	螺絲 Screw (UTB0302 M6-1*12) -----	2
27	8MM06401610A	螺絲 Screw (CT0625 M6-1*16) -----	4
28	4UTD000254	線夾 Cord Clamp -----	4
29	8MC04280807D	螺絲 Screw (CT0130 M4-0.7*8) -----	4
30	8MA08500613A	螺帽 Nut (RP0208 M8-1.25*6) -----	1
31	4UTB020212	擋片 Stopper -----	1
**32	PFE2P	壓腳提昇組 Presser Foot Lifter,C.Set -----	1
33	2200000816	彈簧 Spring -----	1
34	8MB04280607M	螺樁 Stud (UTC2-01-34 M4-0.7*5.5) -----	1
35	4UTB010245	定位環 Collar -----	1
36	8MC95300606F	螺絲 Screw (CT0823 M4.5-0.75*5) -----	1
**37	4PFE1P0121	磁力線圈 Presser Foot Lifter Solenoid -----	1
38	8MK04280507A	螺絲 Screw (WPC0106 M4-1.7*5) -----	2
39	4UTB000336	安全開關 Saftey Switch -----	1
40	8MC03201606D	螺絲 Screw (UTB03351 M3-0.5*16) -----	2
41	PFE02	壓腳提昇組 Presser Foot Lifter,C.Set -----	1
42	4PFE010101	磁力線圈 Presser Foot Lifter Solenoid -----	1
43	4PFE020102	接頭 Joint -----	1
44	4PFE020103	固定座 Bracket -----	1
45	4PFE020104	固定座 Bracket -----	1
46	2100000323	墊圈 Washer (SH0323) -----	4
47	4PFE010106	彈簧 Spring -----	1
48	8MP05321610A	螺絲 Screw (UTC02-04-74 M5-0.8*16) -----	3
49	4UTB01A0255	定位環組 Collar Asm-----	1
50	4PFE010113	套管 Clutch Sleeve -----	1

\*\*配合RP 使用

5. UTC03 / UTC07 電控式組件 Electric Type Components For UTC03 / UTC07

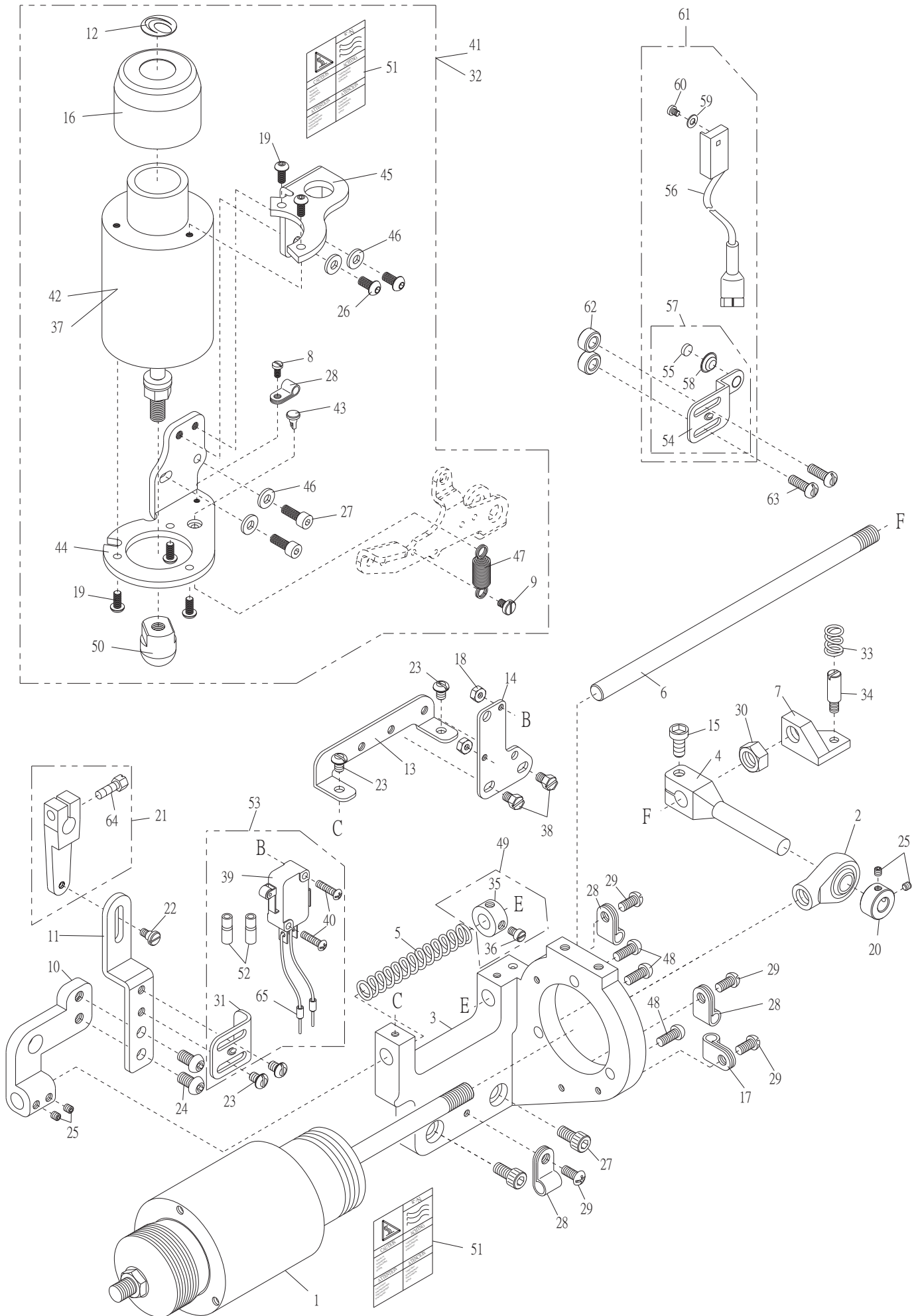

5. UTC03 / UTC07 電控式組件 Electric Type Components For UTC03 / UTC07

序號 Ref.No.	圖號 Parts No.	名稱 Description	單位用量 Amt .Req.
51	4UTC000139	貼紙 Paster -----	2
52	4UTB020228	絕緣套管 Bushing -----	2
53	4UTB02A0255	觸控支架組 One Touch Type Safety Switch SET. -----	1
*54	4UTB020259	支架 Knife Holder Bracket -----	1
*55	4UTB000444	磁鐵 Magnet -----	1
*56	4UTB020256	安全開關 Safety Switch -----	1
*57	4UTB02A0249	支架組 Knife Holder Bracket Asm.-----	1
*58	4UTB020250	銅扣 Brass Button -----	1
*59	2200001025	墊圈 Washer -----	1
*60	8SB44400507A	螺絲 Screw -----	1
*61	4UTB02A0253	磁控支架組 Magnetic Type Safety Switch SET. -----	1
*62	2200001141	隔環 Spacer -----	2
*63	8MB04281207K	螺絲 Screw (CT0239 M4-0.7*12) -----	2
64	8MK95301407A	螺絲 Screw (CT0837 M4.5-0.75*14) -----	1
65	4UTB020272	公端子 Power cord -----	2

\* 磁控支架組用 For Magnetic Type Safety Switch SET