

1. CTD9611 本體與外裝零件(一) Frame Components For CTD9611(一)

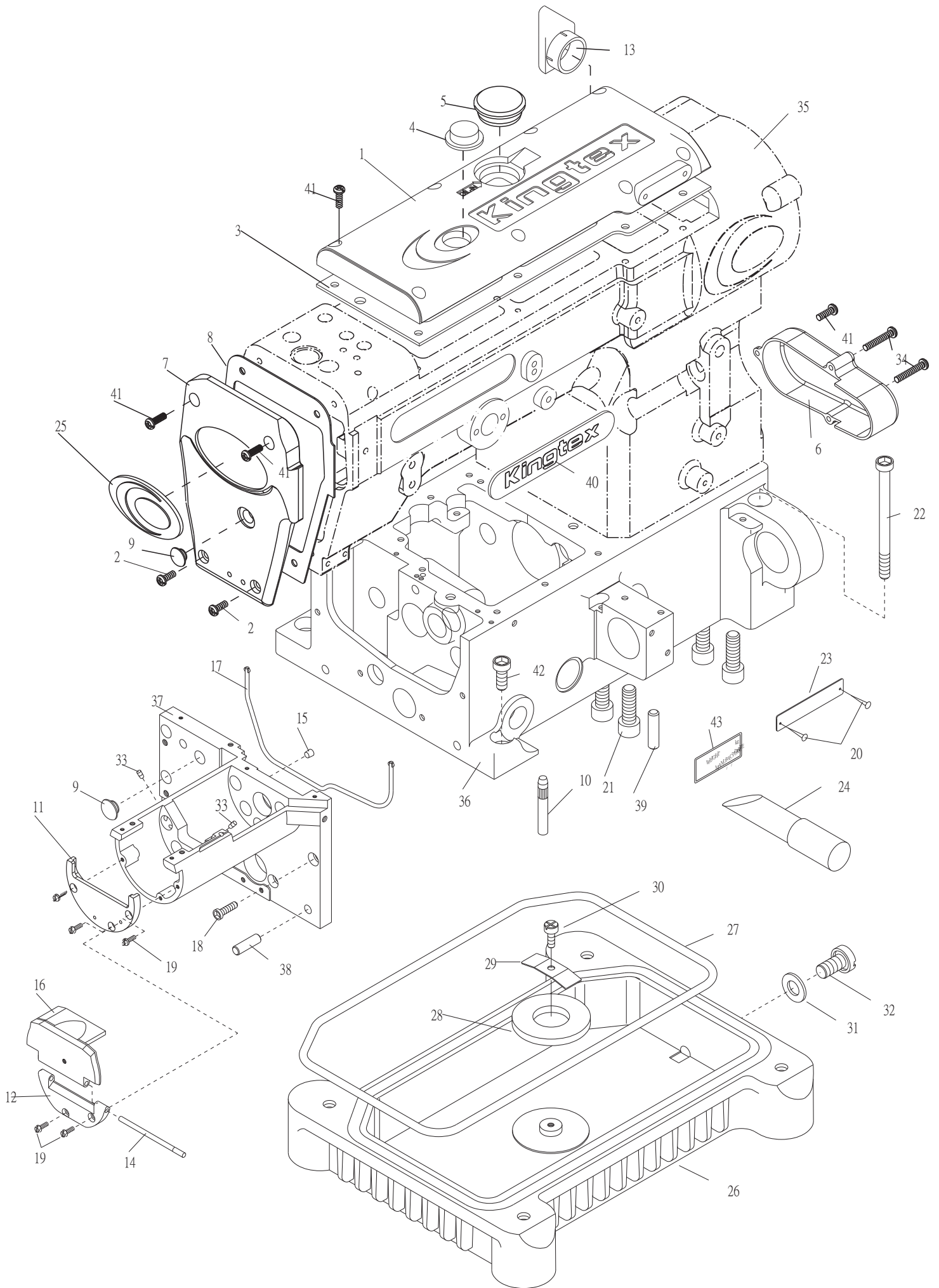

1. CTD9611 本體與外裝零件(一) Frame Components For CTD9611 (一)

序號 Ref.No.	圖號 Parts No.	名稱 Description	單位用量 Amt .Req.
1	22400001011	上軸蓋 Top Cover -----	1
2	8MC04281007D	螺絲 Screw (CT0113 M4-0.7*10) -----	2
3	22400001031	油封 Gasket -----	1
4	22400001041	油鏡 Oil Window -----	1
5	22200002551	孔塞 Plug -----	1
6	2246110106	側蓋 Side Cover -----	1
7	22400001071	針棒蓋 Needle Cover -----	1
8	2240000108	油封 Gasket -----	1
9	22000001091	孔塞 Plug -----	2
10	2200000110	下座腳樁 Supporting Bar -----	4
11	22600001111	側蓋 Side Cover -----	1
12	2260000112	絞鏈 Hinge -----	1
13	22400001131	導風管 Guid Pipe-----	1
14	2260000114	軸 Shaft -----	1
15	22000002471	孔塞 Plug -----	1
16	2260000113	下軸側蓋 Side Cover -----	1
17	2260000117	油封 Gasket -----	1
18	8MM05321409A	螺絲 Screw (CT0632 M5-0.8*14) -----	5
19	8MB03200806K	螺絲 Screw (CT0623 M3-0.5*8) -----	5
20	66620	鉚釘 Rivet -----	2
21	8MM10603016A	螺絲 Serew (CT0138 M10-1.5*30) -----	4
22	8MM08508513B	螺絲 Serew (CT960122 M8-1.25*30) -----	1
23	66480-14	機器號碼牌 Machine No. Plate -----	1
24	2260000124	油面鏡 Oil Sign Gauge-----	1
25	66484-11	銘板 Plate -----	1
26	2220000126	油盤 Oil Reservoir -----	1
27	2200000127	油封 Gasket -----	1
28	2200000128	磁鐵 Magnet -----	1
29	2200000129	壓板 Holder -----	1
30	8MC04280807D	螺絲 Screw (CT0130 M4-0.7*8) -----	1
31	2100000244	油封 Seal -----	1
32	8SM95281017A	螺樁 Stud (SH0243 3/8"-28*10) -----	1
33	2100000327	孔塞 Plug -----	2
34	8MC04283307D	螺絲 Screw (C80147 M4-0.7*33) -----	2
35	2240000135A	車頭 Frame Unit -----	1
36	2260000135B	車頭下座 From Frame Unit -----	1
37	2260000135C	前車頭下座 From Frame Unit -----	1
38	90ST0620	定位銷 Knock Pin (CT960138)-----	2
39	2200000139	定位銷 Knock Pin -----	2
40	66485-9	上車頭銘板 Plate -----	1
41	8MC04281207D	螺絲 Screw (CT0102 M4-0.7*12) -----	11
42	8MM08502013A	螺絲 Screw (CT0106 M8-1.25*20) -----	3
43	66477-4	重量貼紙 Weight Paster -----	1

2. CTD9611 本體與外裝零件(二) Frame Components For CTD9611 (二)

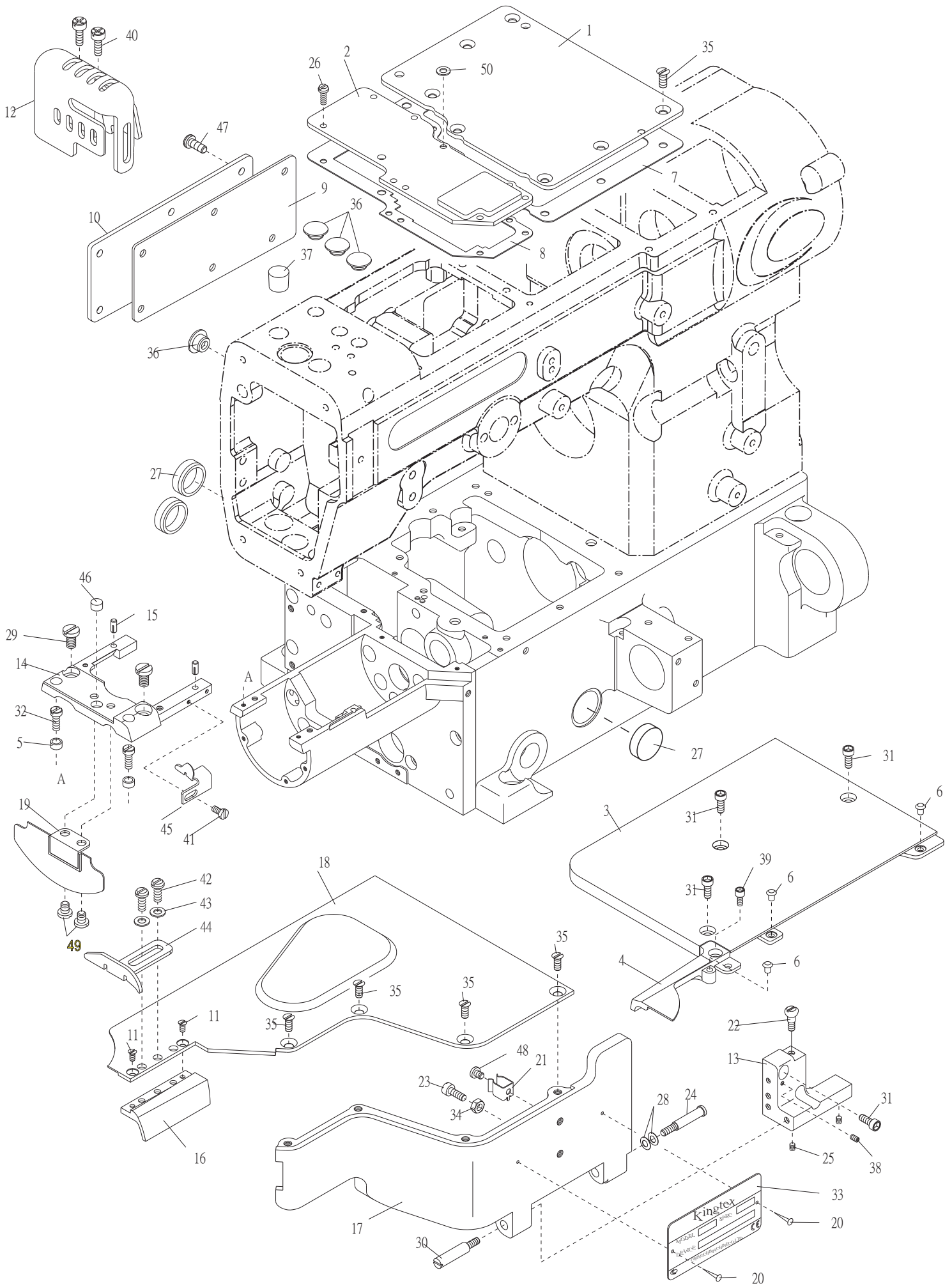

2. CTD9611 本體與外裝零件(二) Frame Components For CTD9611 (二)

序號 Ref.No.	圖號 Parts No.	名稱 Description	單位用量 Amt. Req.
1	2260000201	下軸內蓋 Lower Shaft Cover -----	1
2	2260000202	封蓋 Rear Cover -----	1
3	2260000203	下軸外蓋 Cloth Plate -----	1
4	22600002041	滑道 Guide -----	1
5	2260000205	隔環 Spacer -----	2
6	2260000206	減震橡膠 Rubber Cushion -----	3
7	2260000207	油封 Gasket -----	1
8	2260000208	油封 Gasket -----	1
9	2200000209	油封 Gasket -----	1
10	2200000210	上軸背蓋 Rear Cover -----	1
11	8ME03200506A	螺絲 Screw (CT0341 M3-0.5*4.5) -----	2
12	2270000212	針棒護蓋 Needle Bar Protector -----	1
13	2260000213	前蓋座 Front Cover Support -----	1
14	22600002141	針鉸座 Needle Plate Seat -----	1
15	2260000215	定位銷 Knock Pin -----	2
16	2260000216	活動塊 Movable Block -----	1
17	2260000217	下座前蓋 Front Cover -----	1
18	22600002181	護線蓋 Cloth Plate -----	1
19	2260000219	油封 Gasket -----	1
20	66620	鉚釘 Rivet -----	2
21	2200000121	夾簧 Latch Spring -----	1
22	8MD04281408C	螺樁 Stud (CT0222 M4-0.7*5) -----	1
23	8MB04281007K	螺絲 Screw(CT1237 M4-0.7*10) -----	1
24	8MB04284209E	螺樁 Stud (FT0244 M4-0.7*42) -----	1
25	8MN03200300A	螺絲 Screw (CT0115 M3-0.5*3) -----	2
26	8MB85240806K	螺絲 Screw (CT0635 M3.5-0.6*8) -----	7
27	22000002451	孔塞 Plug -----	3
28	2200000228	孟形墊圈 Disk Washer -----	2
29	8MB04280607A	螺絲 Screw (CT350202 M4-0.7*6) -----	2
30	8MB04280605M	螺樁 Stud (CT0230 M4-0.7*6) -----	1
31	8MM04281207A	螺絲 Screw (CT0202 M4-0.7*12) -----	5
32	8MB03200705A	螺絲 Screw (CT960232 M3-0.5*6.5) -----	2
33	66485-1	車型銘板 Model Plate -----	1
34	8MA04280307A	螺帽 Nut (CT0238 M4-0.7*3) -----	1
35	8ME04281008A	螺絲 Screw (FT0218 M4-0.7*10) -----	11
36	22000001091	孔塞 Plug -----	5
37	22000002081	孔塞 Plug -----	1
38	8MN03200500A	螺絲 Screw (STB0116 M3-0.5*5)-----	1
39	8MM85241006A	螺絲 Screw (CT960239 M3.5-0.6*10) -----	1
40	8MC04280807D	螺絲 Screw (CT0130 M4-0.7*8)-----	2
41	8MB75180505A	螺絲 Screw (CTS0218 M2.5-0.45*5) -----	1
42	8MB04280807K	螺絲 Screw (CT0215 M4-0.7*8) -----	2
43	90PW040	墊圈 Washer -----	2
44	2260110101	右導模 Fabric Guide (R)-----	1
45	2260110102	左導模 Fabric Guide (L)-----	1
46	2270000202	磁鐵 Magnet -----	1
47	8MC04281007D	螺絲 Screw (CT0113 M4-0.7*10)-----	6
48	8MC04280507D	螺絲 Screw (CT0122 M4-0.7*5) -----	1
49	8MB85240505A	螺絲 Screw (PS010106 M3.5-0.6*5) -----	2
50	2100000223	墊圈 Washer -----	1

### 3. CTD9611 導針與張力調整零件 Thread Guide And Tension Components For CTD9611

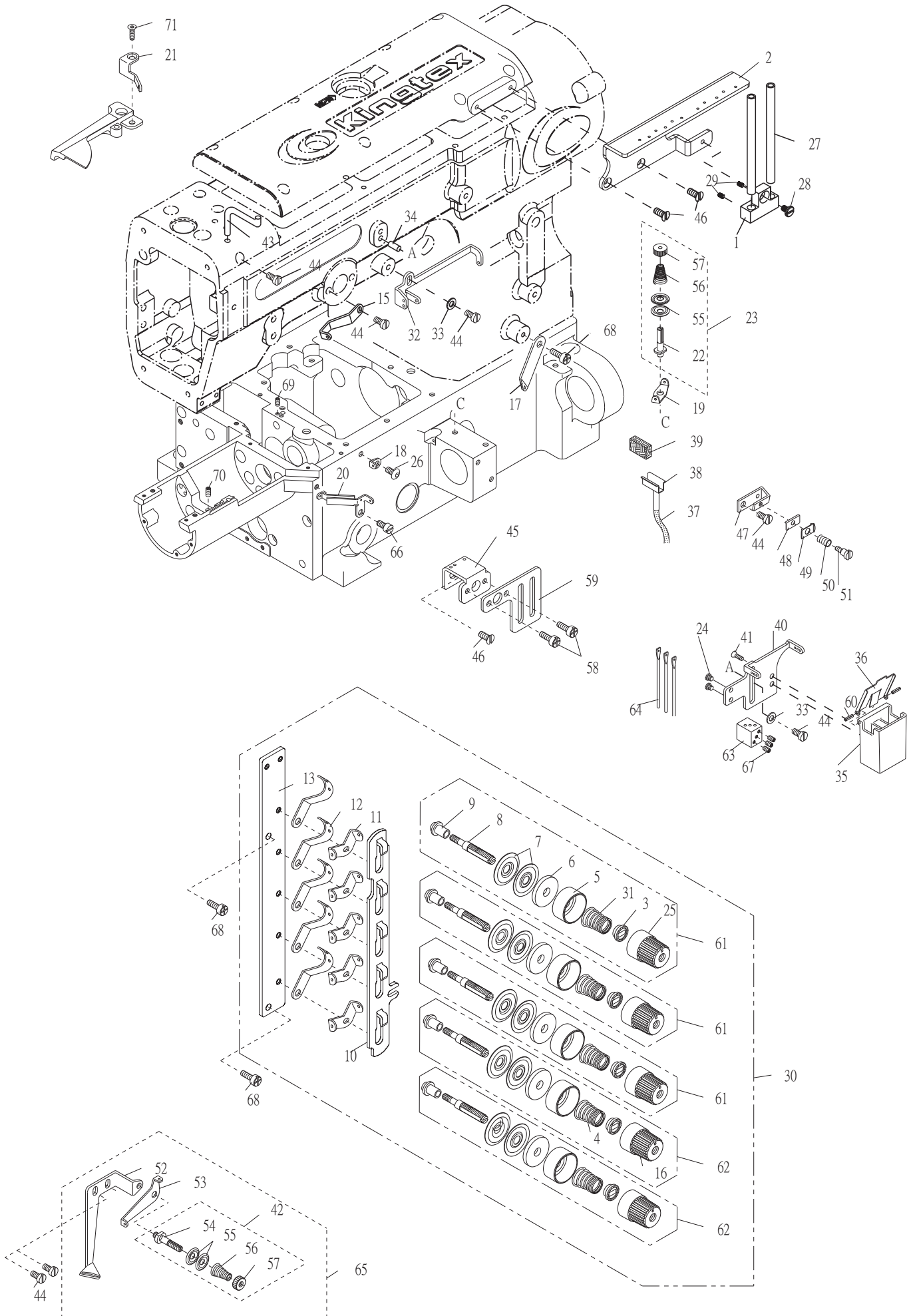

### 3. CTD9611 導針與張力調整零件 Thread Guide And Tension Components For CTD9611

序號 Ref.No.	圖號 Parts No.	名稱 Description	單位用量 Amt .Req.
1	2240000301	導線座 Thread Guide Holder -----	1
2	22400003021	導線座 Thread Guide Holder -----	1
3	2200000303	套管 Bushing -----	5
4	2100041131	彈簧 Spring ( Yellow ) ( SH1131)-----	2
5	2200000305	彈簧座 Spring Seat -----	5
6	2100001127	羊毛氈 Felt -----	5
7	2100001126	張力控制盤 Tension Disc -----	10
8	22000003081	螺樁 Stud -----	5
9	22000003091	隔環 Spacer -----	5
10	4UTB000419	鬆線滑板 Release Wedge -----	1
11	2200000311	導線 Thread Guide -----	5
12	2200000312	導線 Thread Guide -----	5
13	4UTB000420	張力控制組座 Tension Post Support -----	1
14	-----	-----	-
15	2210000317	導線 Thread Guide -----	1
16	2100001121A	張力調整螺帽 Tension Nut ( Yellow ) ( SH1121)-----	2
17	2200000317	導線 Thread Guide -----	1
18	2270000319	導線 Thread Guide -----	1
19	2260000319	導線 Thread Guide -----	1
20	2260000320	導線 Thread Guide -----	1
21	2260000321	導線 Thread Guide -----	1
22	2260000322	螺樁 Stud -----	1
23	226A0000323	張力控制組 Thread Retainer Asm -----	1
24	8MB03200405A	螺絲 Screw (FT0548 M3-0.5*4) -----	2
25	2100001121	張力調整螺帽 Tension Nut ( Red ) ( SH1121)-----	3
26	8MP04280808A	螺絲 Screw ( MT0235 M4-0.7*8) -----	1
27	2200000327	導線管 Thread Guide Pipe -----	2
28	8MB04280608A	螺絲 Screw (UTB0130 M4-0.7*6) -----	1
29	8MN03200300A	螺絲 Screw (CT0115 M3-0.5*3) -----	2
30	224A0000317	鬆線組 Therad Tension Mechanism -----	1
31	2100001123	彈簧 Spring ( Red ) ( SH1123)-----	3
32	2210000326	導線 Thread Guide -----	1
33	2100000223	墊圈 Washer -----	2
34	90ST0410	定位銷 Knock Pin -----	1
35	22000003351	油杯 Cooler Oil Tank -----	1
36	2200000336	油杯蓋 Cooler Oil Tank Cover -----	1
37	66800	油線 Oil Wick -----	1
38	2200000338	線夾 Wick Clamp -----	1
39	2200000339	羊毛氈 Felt -----	1
40	2220000340	導線 Thread Guide -----	1
41	8TE03440806A	螺絲 Screw -----	2
42	227A0000342	張力控制組 Thread Retainer Asm -----	1
43	22000003431	導線 Thread Guide -----	1
44	8MB04280807K	螺絲 Screw (CT0215 M4-0.7*8) -----	7
45	2200000345	導線 Thread Guide -----	1
46	8ME04280708A	螺絲 Screw (CT0206 M4-0.7*7) -----	3
47	2200000347	張力控制組座 Thread Retainer Support -----	1
48	2200000348	針線控制板 Thread Guide Plate -----	1
49	2200000349	針線控制壓板 Tension Control plate -----	1
50	22000003501	彈簧 Spring -----	1

### 3. CTD9611 導針與張力調整零件 Thread Guide And Tension Components For CTD9611

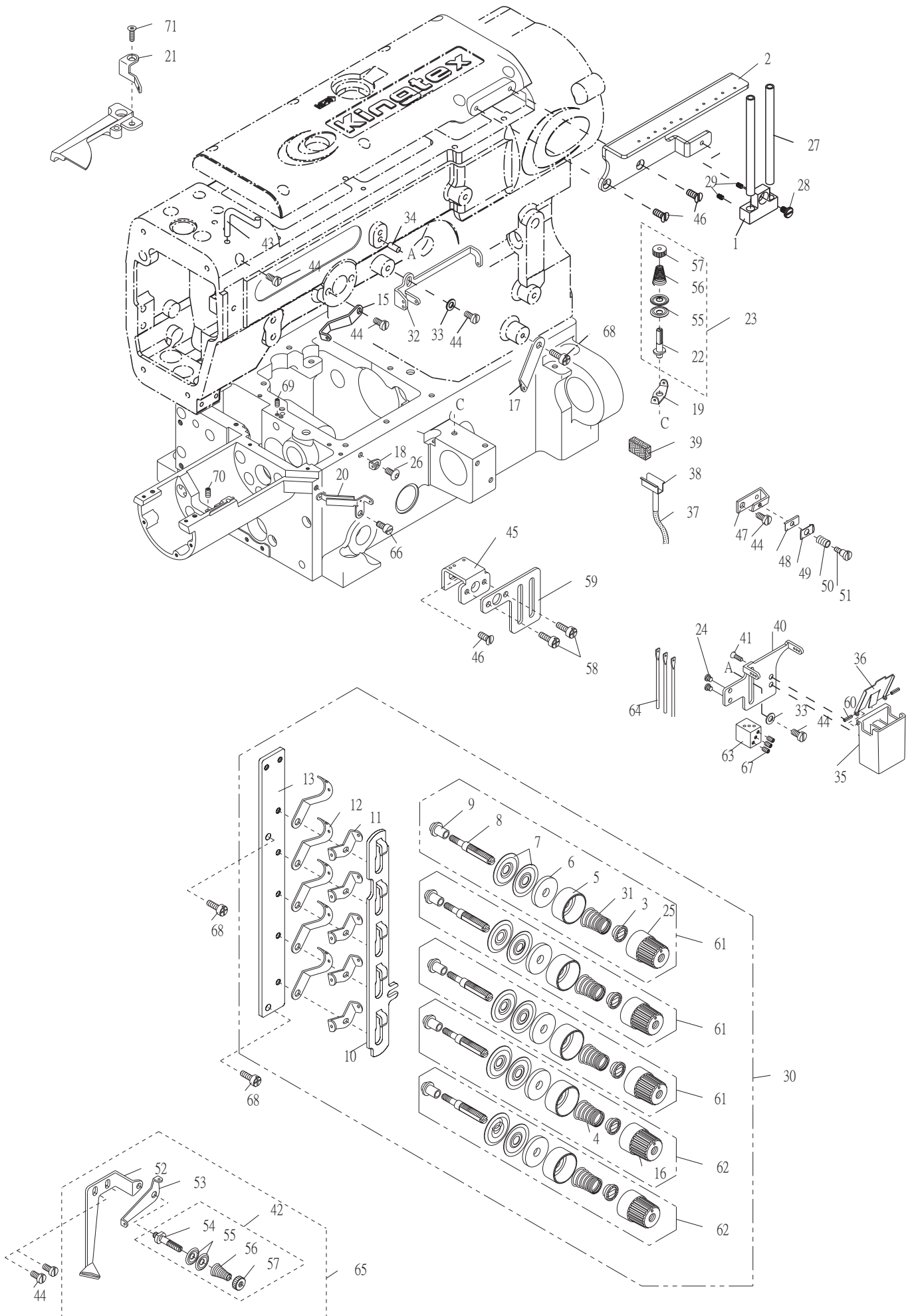

### 3. CTD9611 導針與張力調整零件 Thread Guide And Tension Components For CTD9611

序號 Ref.No.	圖號 Parts No.	名稱 Description	單位用量 Amt .Req.
51	8MC03200807G	螺樁 Stud (CT0351 M3-0.5*8) -----	1
52	2200000352	導線 Thread Guide -----	1
53	2200000353	導線 Thread Guide -----	1
54	2200000354	螺樁 Stud -----	1
55	2200000355	張力控制盤 Tension Disc -----	4
56	2200000356	彈簧 Spring -----	2
57	2200000357	螺帽 Nut -----	2
58	8MC04280507D	螺絲 Screw (CT0122 M4-0.7*5) -----	2
59	2200000359	揚線臂護線罩 Take-up Arm Protect -----	1
60	90SP0206T	彈簧銷 Spring Pin -----	2
61	23100001922	張力調整螺帽 Tension Asm. ( Red )-----	3
62	220A0000315	張力調整螺帽 Tension Asm. ( Yellow )-----	2
63	2220000363	導線桿座 Thread Guide Holder -----	1
64	2220000364	導線桿 Thread Guide -----	3
65	220A0000365	鬆線組 Therad Tension Mechanism -----	1
66	8MB04280607K	螺絲 Screw (MT0233 M4-0.7*6) -----	1
67	8MN03200300A	螺絲 Screw (CT0115 M3-0.5*3) -----	3
68	8MC04280807D	螺絲 Screw (CT0130 M4-0.7*8) -----	3
69	8MN85240300A	螺絲 Screw (UH0302 M3.5-0.6*3) -----	1
70	8MN04280400A	螺絲 Screw (CT0229 M4-0.7*4) -----	1
71	8MQ85241106A	螺絲 Screw (CT960314 M3.5-0.6*11)-----	1

4. CTD9611 軸襯與油封 Bushing And Seal For CTD9611

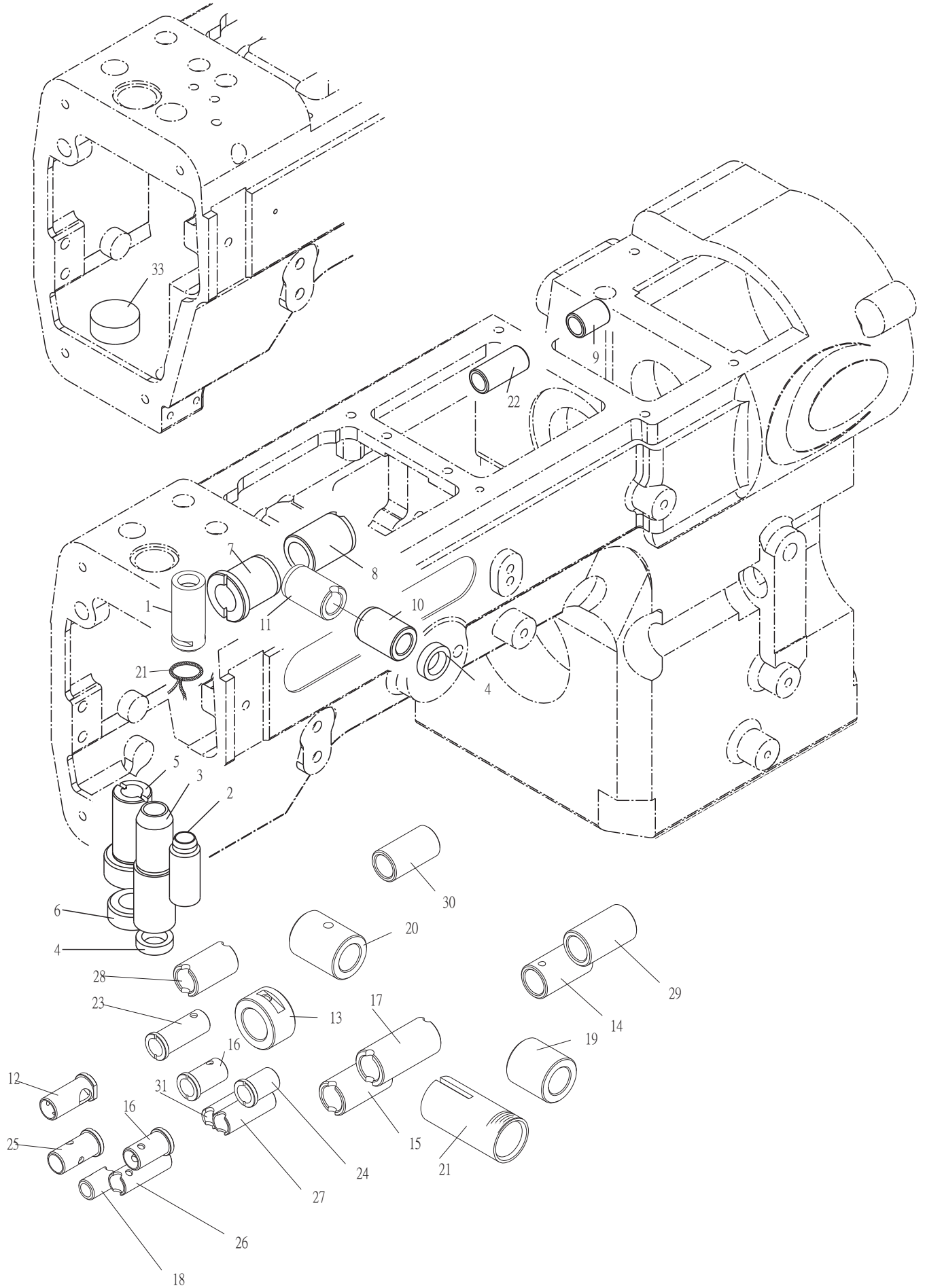

4. CTD9611 軸襯與油封Bushing And Seal For CTD9611

序號 Ref.No.	圖號 Parts No.	名稱 Description	單位用量 Amt .Req.
1	2210000401	軸襯 Bushing -----	1
2	2200000402	軸襯 Bushing -----	1
3	2200000403	軸襯 Bushing -----	1
4	2200000404	油封 Oil Seal -----	2
*5	2220000405	軸襯 Bushing -----	1
*6	2200000406	油封 Oil Seal -----	1
*7	2210000408	軸襯 Bushing -----	1
*8	2200000408	軸襯 Bushing -----	1
9	2240000409	軸襯 Bushing -----	1
10	2200000410	軸襯 Bushing -----	1
11	2200000411	軸襯 Bushing -----	1
12	2260000412	軸襯 Bushing -----	1
13	2260000413	軸襯 Bushing -----	1
14	2260000414	軸襯 Bushing -----	1
15	2260000415	軸襯 Bushing -----	1
16	2260000416	軸襯 Bushing -----	2
17	2260000417	軸襯 Bushing -----	1
18	2260000418	軸襯 Bushing -----	1
19	2200000419	軸襯 Bushing -----	1
20	2200000420	軸襯 Bushing -----	1
21	2200000421	刻線套管 Graduation Bushing -----	1
22	2240000422	軸襯 Bushing -----	1
23	2260000423	軸襯 Bushing -----	1
24	2260000424	軸襯 Bushing -----	1
25	2260000425	軸襯 Bushing -----	1
26	2260000426	軸襯 Bushing -----	1
27	2260000427	軸襯 Bushing -----	1
28	2260000428	軸襯 Bushing -----	1
29	2260000429	軸襯 Bushing -----	1
30	2260000430	軸襯 Bushing -----	1
31	2260000431	軸襯 Bushing -----	1
32	66800	油線 Oil Wick -----	1
**33	2200000422	孔塞 Plug -----	1

\*具有上飾線 With top cover thread  
 \*\*不具有上飾線 Without top cover thread

5. CTD9611 下軸與相關零件 Lower Main Shaft Components For CTD9611

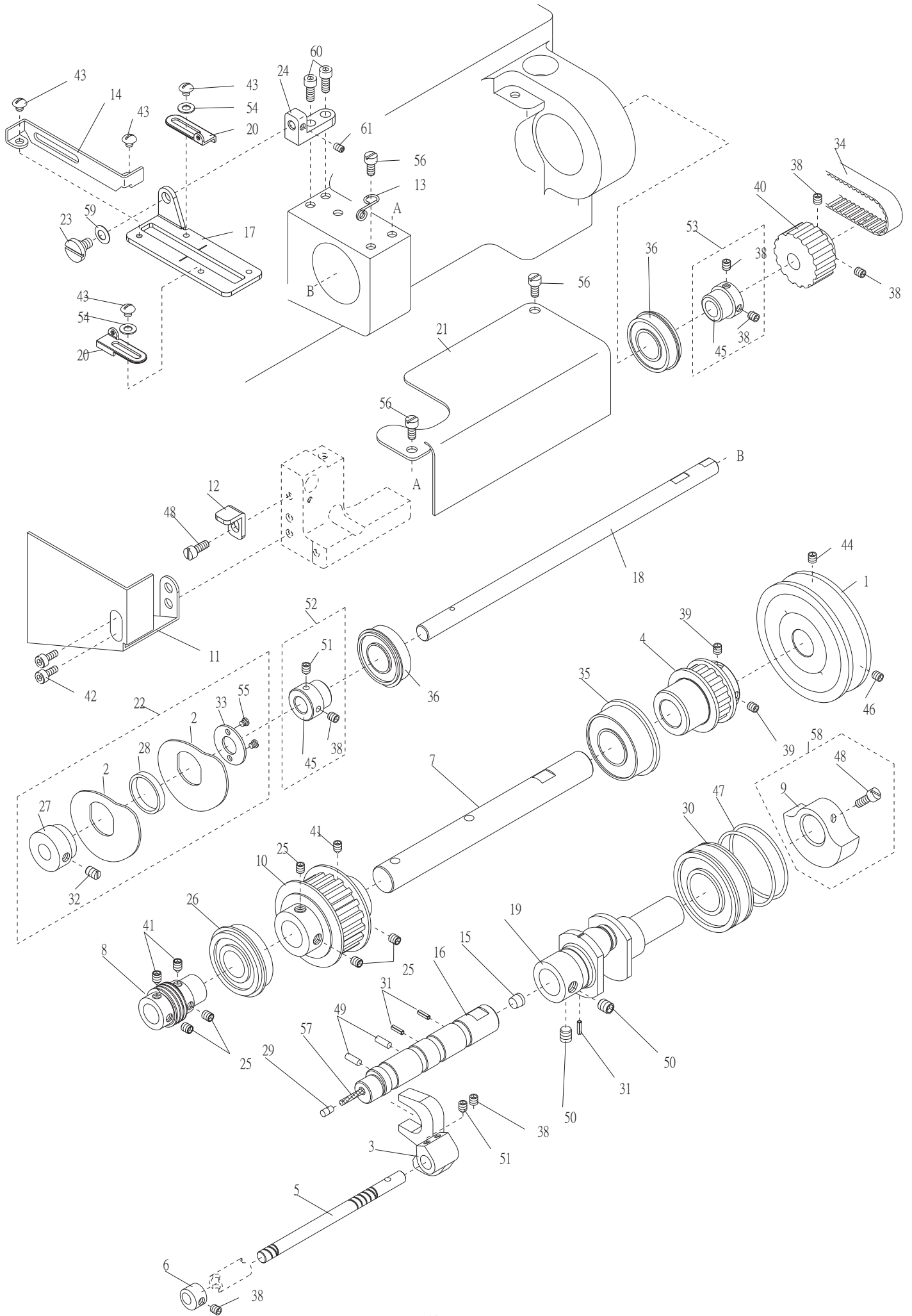

5. CTD9611 下軸與相關零件 Lower Main Shaft Components For CTD9611

序號 Ref.No.	圖號 Parts No.	名稱 Description	單位用量 Amt .Req.
1	2246110501	軸 Shaft -----	1
2	2200000502	揚線凸輪片 Looper Thread Takeup Cam -----	2
3	2260000503	曲柄 Drive Arm -----	1
4	2220000504	齒形皮帶輪 Timeing Pulley -----	1
5	2260000505	軸 Shaft -----	1
6	2260000506	定位環 Collar -----	1
7	-----	-----	-
8	2200000508	蝸桿 Warm -----	1
9	2200000509	平衡錘 Balance Weight -----	1
10	2240000505	齒形皮帶輪 Timeing Pulley -----	1
11	2260000511	凸輪護蓋 -----	1
12	22600005121	定位片 Stopper -----	1
13	22600005131	彈簧 Spring -----	1
14	2260000514	導線 Thread Guide -----	1
15	2200000515	孔塞 Plug -----	1
16	2260000516	軸 Shaft -----	1
17	22600005171	導線固定板 Thread Guide Seat -----	1
18	2260000518	軸 Shaft -----	1
19	2260000519	曲軸 Crank Shaft -----	1
20	22600005201	導線 Thread Guide -----	2
21	2260000521	護蓋 Cover -----	1
22	226A0000522	揚線凸輪組 Looper Thread Takeup Cam Asm -----	1
23	8MB04280608E	螺樁 Stud (C90542 M4-0.7*6.2)-----	1
24	2260000524	固定座 Bracket -----	1
25	8MN06400600A	螺絲 Screw (CT0244 M6-1*6) -----	5
26	90BB2047144	滾珠軸承 Ball Bearing -----	1
27	2260000527	揚線凸輪座 Holder -----	1
28	22000005221	隔環 Spacer -----	1
29	2200001029	孔塞 Plug -----	1
30	90BB2042122	滾珠軸承 Ball Bearing -----	1
31	90SP0206	彈簧銷 Pin -----	3
32	8MH05320400A	螺絲 Screw (CT0523 M5-0.8*4) -----	2
33	2220000533	壓板 Plate -----	1
34	90TB3033GT	齒形皮帶 Timeing Belt -----	1
35	90BB2552154	滾珠軸承 Ball Bearing -----	1
36	90BB152807	滾珠軸承 Ball Bearing -----	2
37	-----	-----	-
38	8MN04280400A	螺絲 Screw (CT0229 M4-0.7*4) -----	7
39	8MN05320500E	螺絲 Screw (CT0903 M5-0.8*5) -----	2
40	2220000540	齒形皮帶輪 Timeing Pulley -----	1
41	8MN06400800C	螺絲 Screw (CT0502 M6-1*8) -----	3
42	8MM04280507A	螺絲 Screw (UH0172 M4-0.7*5) -----	2
43	8MD03200306A	螺絲 Screw (CT0242 M3-0.5*3) -----	4
44	8MM04280807A	螺絲 Screw (MT0124 M4-0.7*8) -----	2
45	2270000545	套管接頭 Joint -----	2
46	8MN03200300A	螺絲 Screw (CT0115 M3-0.5*3) -----	1
47	2200000547	O形油環 O Ring -----	2
48	8MB04280807K	螺絲 Screw (CT0215 M4-0.7*8) -----	3
49	66801	油線 Oil Wick -----	2
50	8MN06400500A	螺絲 Screw (CT0513 M6-1*5) -----	2
51	8MN04280500C	螺絲 Screw (FT1222 M4-0.7*5) -----	2
52	226A0000552	套管接頭組 Joint Asm -----	1
53	222A0000553	套管接頭組 Joint Asm -----	1
54	90PW030	墊圈 Washer -----	2
55	8MB03200405A	螺絲 Screw (FT0548 M3-0.5*4) -----	2
56	8MB04280607K	螺絲 Screw (MT0233 M4-0.7*6) -----	3
57	66800	油線 Oil Wick -----	1
58	222A0000647	平衡錘組 Balance Weight Asm -----	1
59	2200000228	碟形墊圈 Disk Washer -----	1