

1.FTG4700/FTG6500/FT7200 超高速繃縫車縫製專用零件
 FTG4700/FTG6500/FT7200 Special Parts For Heavy Material Application

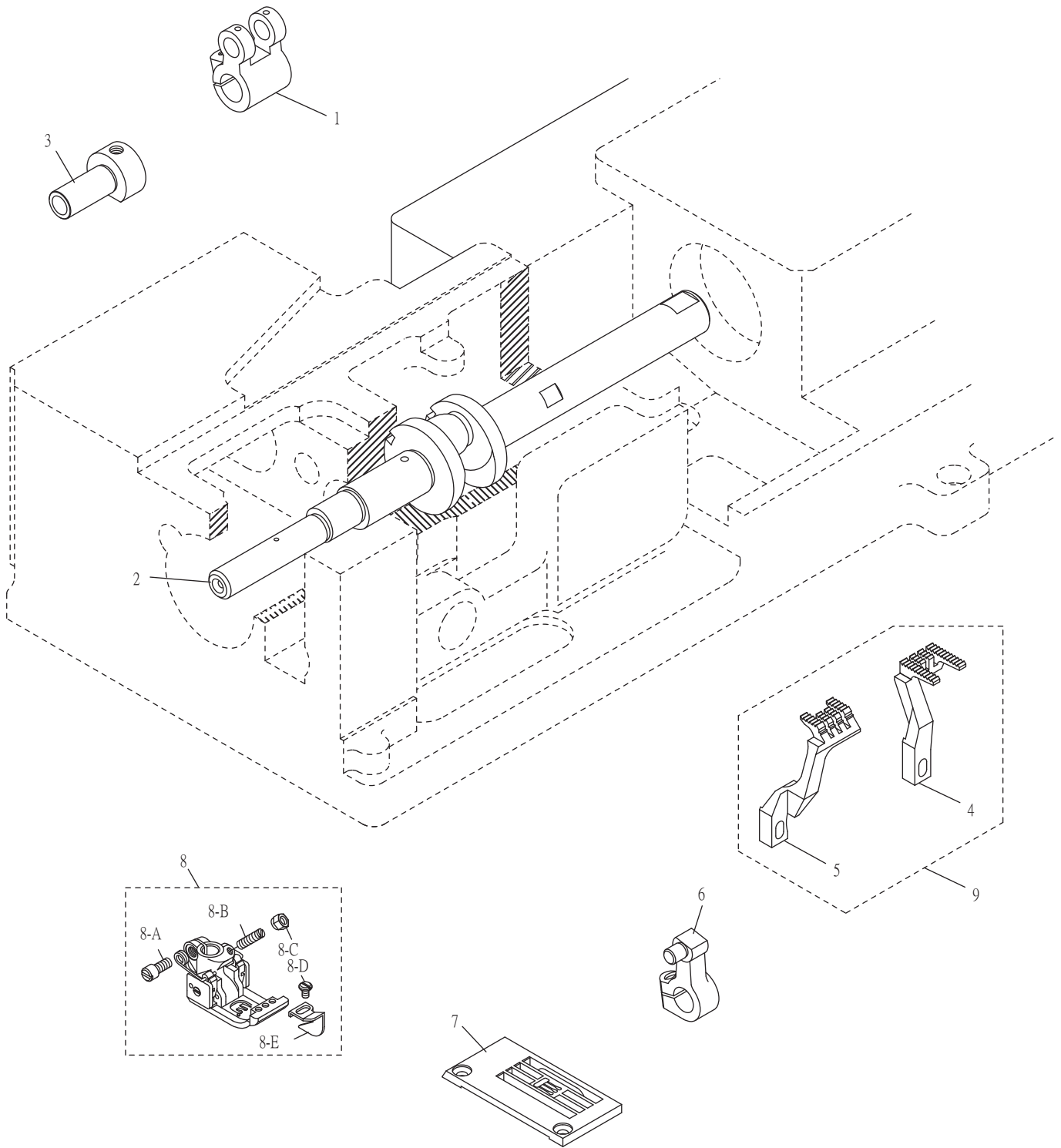

7. 針板 Needle Plate

針板針距 Needle Plate	圖 號 Parts No.
5.6	5220TP00567
6.4	5220TP00645

8. 壓腳 Press Foot

壓腳針距 Press Foot	圖 號 Parts No.
5.6	5220PF00563
6.4	5220PF00643

1.FTG4700/FTG6500/FT7200 超高速繃縫車縫製專用零件

FTG4700/FTG6500/FT7200 Special Parts For Heavy Material Application

序號	物料編號	名稱	單位用量
Ref. No.	Parts Number	Description	Amt.Req.
1	2211000101	曲柄 Shaft -----	1
2	2211000102	曲軸 Crank Shaft -----	1
3	2211000103	懸臂 Guide -----	1
4	5221FD00566	主送布齒 Main Feed Dog -----	1
5	5221DF00561	副送布齒 Diff.Feed Dog -----	1
6	2210390256	曲柄 Lever -----	1
7	-----	針板 Needle Plate -----	1
8	-----	壓腳組 Press Foot -----	1
8-A	8MC85240705A	螺絲 Screw -----	1
8-B	5221PF0956C	螺絲 Screw -----	1
8-C	5220PF0356D	螺帽 Nut -----	1
8-D	8SB24560405A	螺絲 Screw (SH04-13 3/32"-56*4) -----	1
8-E	5220PF0056L	導布定規 Curl Guard -----	1
9	5221DG0016	送布齒組 Feed Dog Asm. -----	1