

1. PA 直角車縫裝置 PA DEVICE

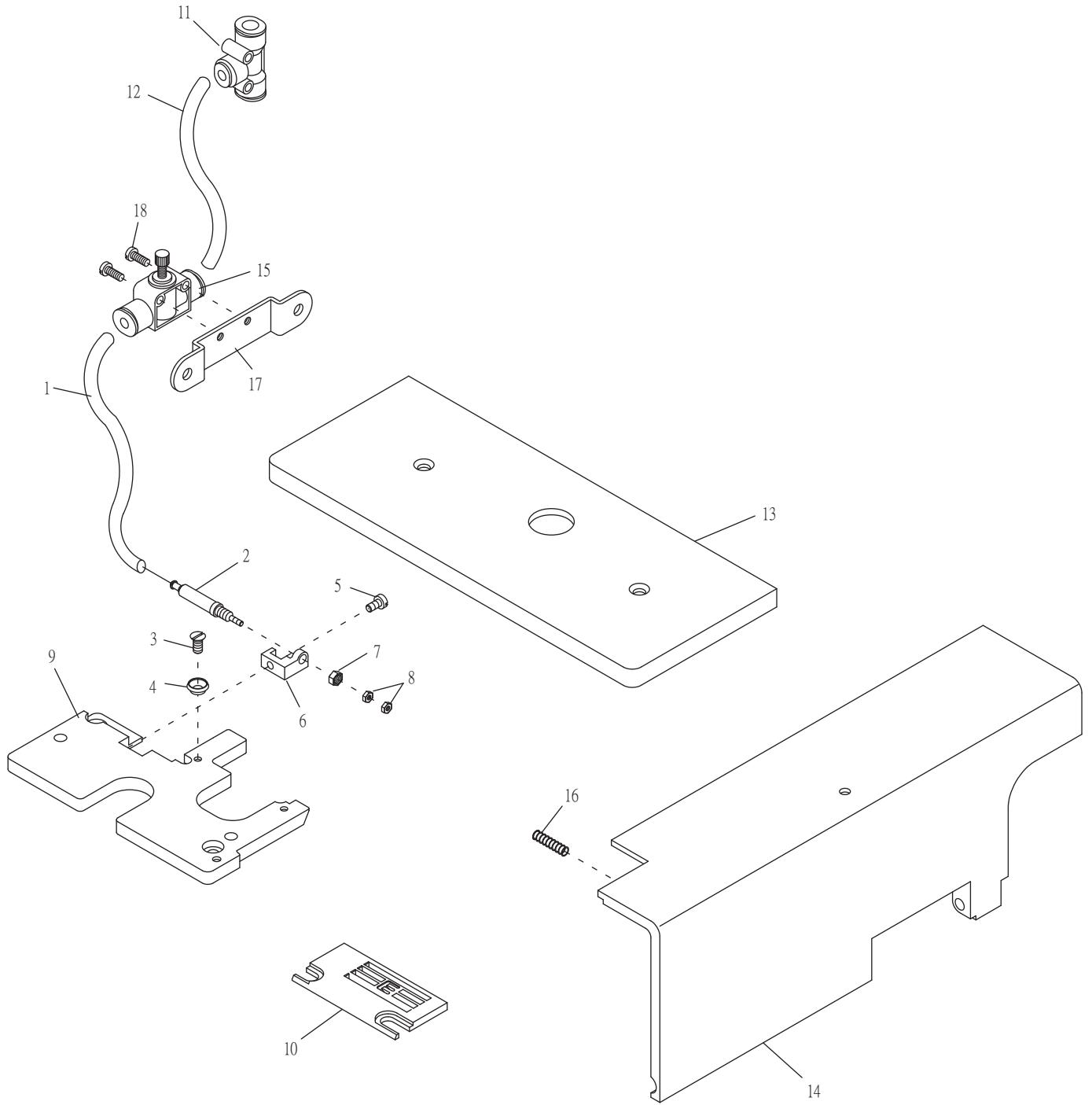

1. PA 直角車縫裝置PA DEVICE

序號	物料編號	名稱	單位用量
Ref. No.	Parts Number	Description	Amt. Req.
1	4PA0000101	空壓管 Vinyl Tube -----	1
2	4PA0000102	氣缸 Air Cylinder -----	1
3	8SE36400806A	螺絲 Screw (SH0530 9/64"-40*6) -----	2
4	4PA0000104	隔環 Spacer -----	2
5	8MB03200606K	螺絲 Screw (CT1207 M3-0.5*6) -----	1
6	4PA0000106	氣缸座 Cylinder Support -----	1
7	4PA0000107	螺帽 Nut (M4-0.7*2.4) -----	1
8	4PA0000108	螺帽 Nut (M2-0.4*1.5) -----	2
9	4PA0000109	針板座 Needle Plate Seat -----	1
10	5221TP00563	針板 Needle Plate -----	1
11	4WPC000101	T形管接頭 T Connector -----	1
12	4WPC000102	空氣管 Air Tube -----	1
13	4PA0000113	左布板 Cloth Plate -----	1
14	4PA0000114	下座前蓋 Front Cover -----	1
15	4WPC000114	節流閥 Speed Controller -----	1
16	4PA0000116	彈簧 Spring -----	1
17	4WPC000113	支架 Holder Bracket -----	1
18	8MC03201306D	螺絲 Screw (UTB0335 M3-0.5*13) -----	2

2. PA 空壓組件(A) PA Compressed Air Components (A)

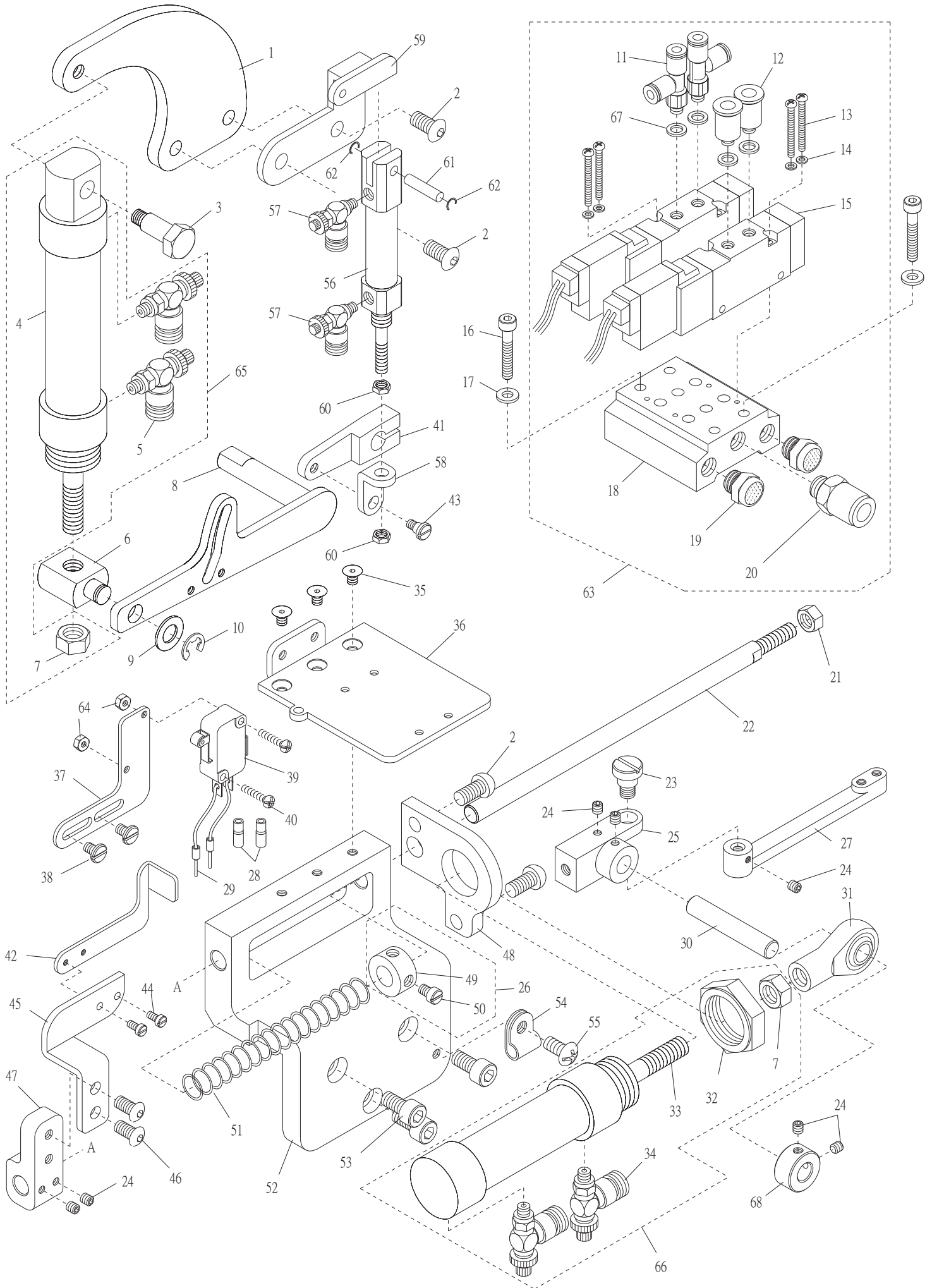

2. PA 空壓組件(A) PA Compressed Air Components (A)

序號	物料編號	名稱	單位用量
Ref. No.	Parts Number	Description	Amt. Req.
1	4UTB000301	支架 Cylinder Holder Bracket -----	1
2	8MP06401211A	螺絲 Screw (UTB0302 M6-1*12) -----	4
3	8MK06402314G	螺樁 Stud (UTB0303 M6-1*6) -----	1
4	4UTB000304	氣壓缸 Cylinder -----	1
5	4UTB000305	節流閥 Speed Controller -----	2
6	4UTB000306	氣缸接頭 Joint -----	1
7	8MA08500613A	螺帽 Nut (RP10208 M8-1.25*6) -----	2
8	4UTB000308	揚昇臂 Lifter Arm -----	1
9	2200000716	墊圈 Washer -----	1
10	90ER060	E形扣環 E Ring -----	1
11	4UTB010311	空氣管接頭 Connector -----	2
12	4UTB010312	空氣管接頭 Connector -----	2
13	4UTB010313	螺絲 Screw (UTB0313 M2.5*0.45*25)-----	4
14	4UTB010314	彈簧墊圈 Spring Washer -----	4
15	4UTB010315	換向閥 Electromagnetic Valve -----	2
16	8MM04282507B	螺絲 Screw (FT0719 M4-0.7*25) -----	2
17	90SW040	彈簧墊圈Spring Washer -----	2
18	4UTB010318	換向閥座Electromagnetic Valve Base -----	1
19	4UTG010319	消音器Silencer -----	2
20	4UTB020266	空氣管接頭Elbow Connector -----	1
21	8MA08500613A	螺帽Nut (RP0208 M8-1.25*6) -----	1
22	4UTD000222	軸Shaft -----	1
23	4UTD000223	螺樁Stud -----	1
24	8MN04280400A	螺絲Screw (CT0229 M4-0.7*4)-----	7
25	4UTD000225	承座Plunger -----	1
26	4UTB01A0255	定位環組Collar Asm-----	1
27	4UTD0002271	連結桿Connecting Rod -----	1
28	4UTB020228	絕緣套管 Bushing -----	2
29	4UTB020272	公端子 Power cord -----	2
30	4UTB0003251	軸Shaft -----	1
31	4UTD000231	球軸連桿Plunger Connecting Rod -----	1
32	8MA22600729A	螺帽Nut -----	1
33	4UTD000233	氣壓缸Cylinder -----	1
34	4UTB000344	節流閥Speed Controller -----	2
35	8MQ04280808A	螺絲Screw (UTB0109 M4-0.7*8) -----	3
36	4UTB0003321	基板Base -----	1
37	4UTD000237	安全開關座Safety Switch Bracket -----	1
38	8MB04280608A	螺絲Screw (UTB0130 M4-0.7*6) -----	2
39	4UTB000336	安全開關Safety Switch -----	1
40	8MC03201606D	螺絲Screw (UTB03351 M3-0.5*16) -----	2
41	4UTB010337	曲柄Tension Release Lever -----	1
42	4UTD000242	支架Holder Bracket -----	1
43	8MB04280908G	螺樁Stud (UTB0339 M4-0.7*8) -----	1
44	8MB03200506K	螺絲Screw (CT0525 M3-0.5*5) -----	2
45	4PA0000245	連桿Connecting Plate -----	1
46	8MP05321210A	螺絲Screw (UTB0340 M6-1*12) -----	2
47	4UTD000247	連結塊Connecting Block -----	1
48	4UTD000248	氣缸座Cylinder Barcket -----	1
49	4UTB010245	定位環Collar -----	1
50	8MC95300606F	螺絲Screw (CT0823 M4.5-0.75*5) -----	1

2. PA 空壓組件(A) PA Compressed Air Components (A)

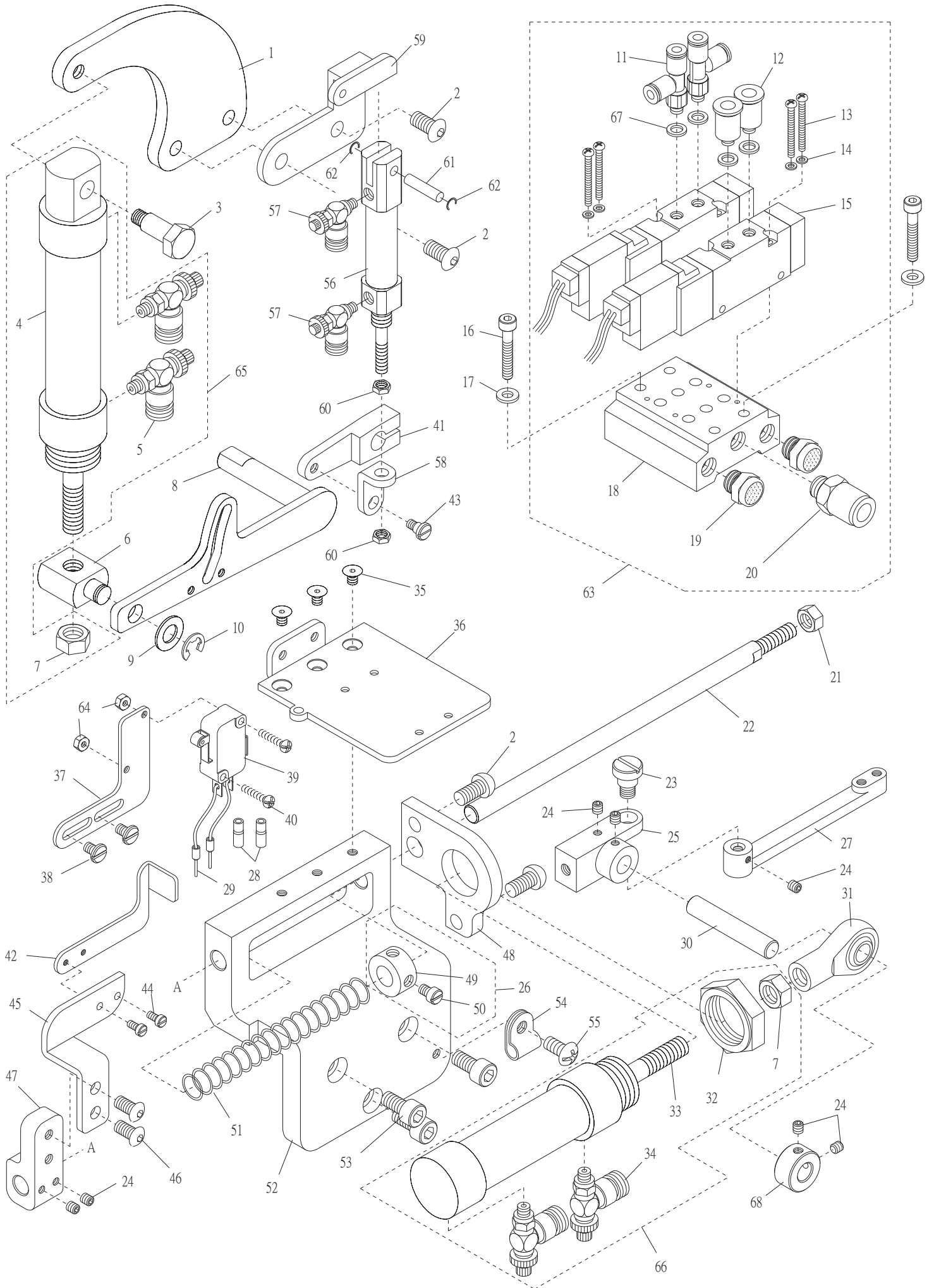

2. PA 空壓組件(A) PA Compressed Air Components (A)

序號	物料編號	名稱	單位用量
Ref. No.	Parts Number	Description	Amt.Req.
51	4UTB000346	彈簧 Spring -----	1
52	4UTD000252	空壓組件座 Trimming Cylinder Support -----	1
53	8MM06401210A	螺絲 Screw (FT1103 M6-1*12) -----	3
54	4UTD000254	線夾 Cord Clamp -----	1
55	8MC04280807D	螺絲 Screw (CT0130 M4-0.7*8) -----	1
56	4PA0000256	氣壓缸 Cyliner -----	1
57	4STB000121	節流閥 Speed Controller -----	2
58	4PA0000258	接頭 Joint -----	1
59	4PA0000259	接頭 Joint -----	1
60	8MA04280307A	螺帽 Nut -----	2
61	4PA0000261	銷 Pin -----	1
62	4PA0000262	C型扣環 C-Ring -----	2
63	4UTB01A03491	換向閥組 Electromagnetic Valve Asm -----	1
64	8MA03200306A	螺帽 Nut (FTB0111 M3-0.5*3) -----	2
65	4UTB01A0350	氣壓缸組 Cyliner Asm-----	1
66	4UTD01A0257	氣壓缸組 Cyliner Asm-----	1
67	4UTB010353	墊圈 Washer -----	4
68	4UTB010152	定位環 Collar -----	1

3. PA 空壓組件(B) PA Compressed Air Components (B)

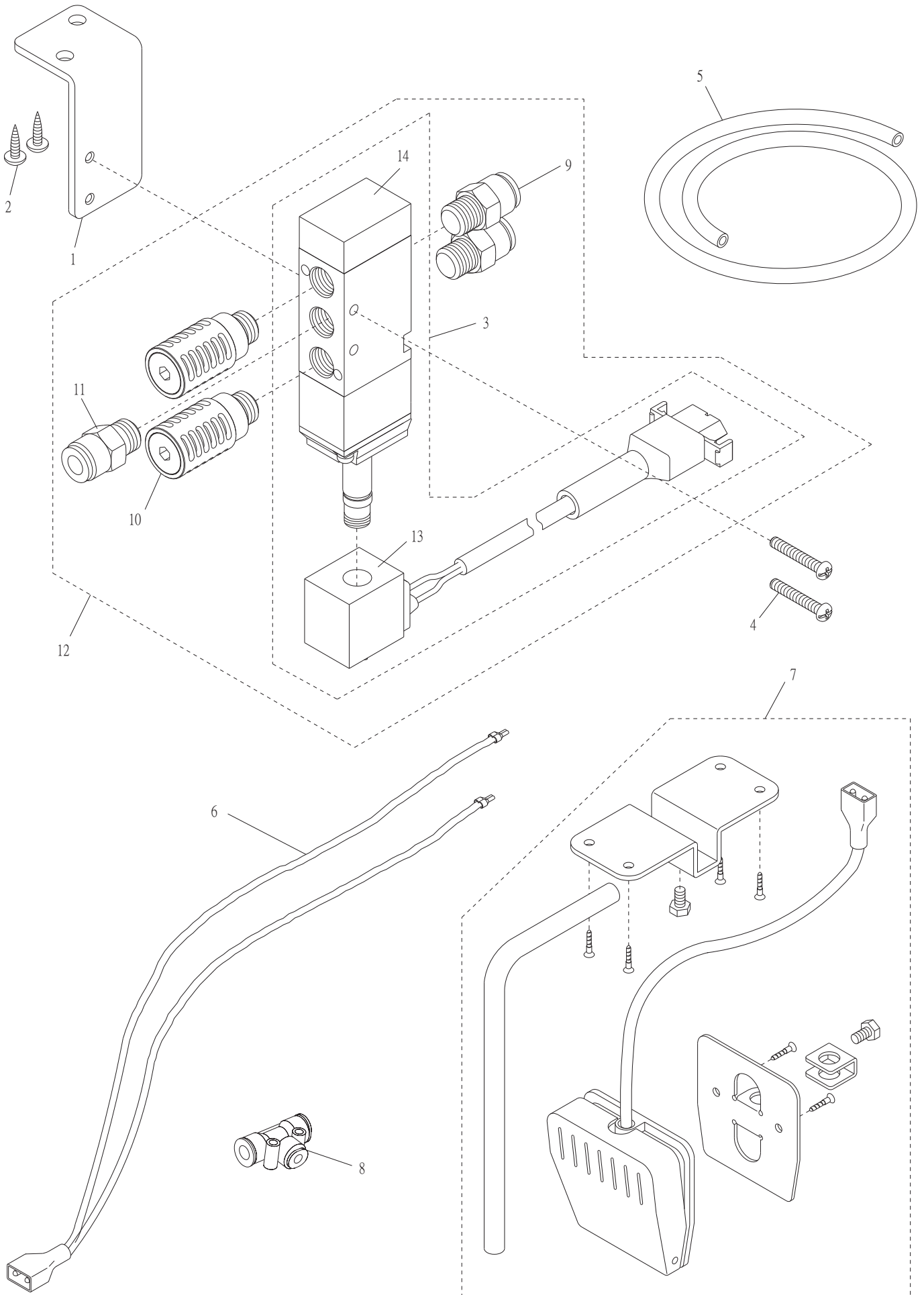

3. PA 空壓組件(B) PA Compressed Air Components (B)

序號	物料編號	名稱	單位用量
Ref. No.	Parts Number	Description	Amt.Req.
1	4TC00103011	楔片座 Wedfe Seat -----	1
2	8WD30000015B	木螺絲 Wood Screw -----	2
3	4PA000A0303	換向閥 Electromagnetic Valve -----	1
4	8MC03202006D	螺絲 Screw (FTC10304 M3-0.5*20) -----	2
5	4TC0010305	空氣管 Air Tube -----	1
6	4PA0000306	電源線 Cable -----	1
7	4TC001A0310	膝控開關組 Knee Switch, Complete Set -----	1
8	2206110226	T型管接頭 T Connector -----	1
9	4PA0000309	快速接頭 Connector -----	2
10	4PA0000310	消音器 Silencer -----	2
11	4UTB000312	快速接頭 Connector -----	1
12	4PA000A0312	換向閥組 Electromagnetic Valve Asm. -----	1
13	4PA0000314	線圈 Solenoid (DC 24V) -----	1
14	4PA0000315	換向閥 Electromagnetic Valve -----	1

4. PA 鬆線機構及更換零件 PA Thread Tension Components And Motor Components

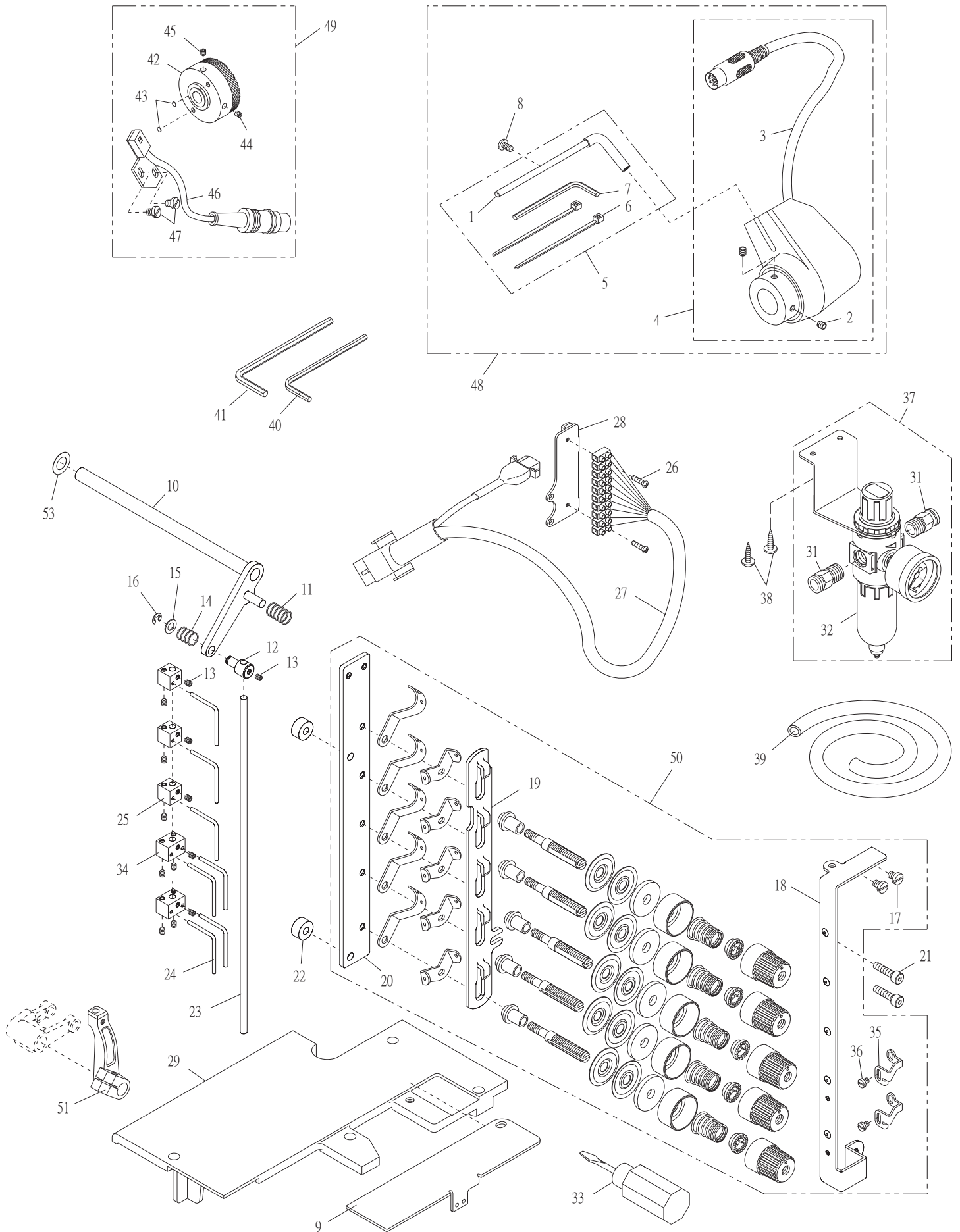

4. PA 鬆線機構及更換零件 PA Thread Tension Components And Motor Components

序號	物料編號	名稱	單位用量
Ref. No.	Parts Number	Description	Amt. Req.
1	4UTB020308	止動桿 Stopper -----	1
2	8MN06400600A	螺絲 Screw (CT0244 M6-1*6) -----	2
3	4UTB020303	針定位器 Synchronizer -----	1
4	4UTB02A0304	針定位器組 Mount- on Type Synchronizer -----	1
5	4UTB02A0305	止動桿組 Stopper Set Asm. -----	1
6	4UTB020306	束線 Plastic Binding Wire -----	2
7	4UTB020307	六角板手 Allen Key -----	1
8	8MC04281007A	螺絲 Screw (FT0217 M4-0.7*10) -----	1
9	4UTD0003091	防塵蓋 Dust Cover -----	1
10	4UTB000410	曲柄 Tension Release Shaft -----	1
11	4UTB000411	彈簧 Spring -----	1
12	4UTB000412	接頭 Pin -----	1
13	8MN03200300A	螺絲 Screw (CT0115 M3-0.5*3) -----	(see the table)
14	4UTB000414	彈簧 Spring -----	1
15	2200001025	墊圈 Washer -----	1
16	90ER030	E形扣環 E Ring -----	1
17	8MB04280507K	螺絲 Screw (FT0235 M4-0.7*5) -----	2
18	4UTB000418	導線 Thread Guide Eyelet -----	1
19	4UTB000419	鬆線滑板 Release Wedge -----	1
20	4UTB000420	導線座 Tension Post Support -----	1
21	8MM04281607A	螺絲 Screw (FT0202 M4-0.7*16) -----	2
22	4UTB000422	隔環 Spacer -----	2
23	4UTB000423	導桿 Guide Bar -----	1
24	4UTB000424	鬆線桿 Release Bar -----	(see the table)
25	4UTB000425	鬆線座 Thread Pull-off Block -----	(see the table)
26	8MC03201006D	螺絲 Screw (UTB0426 M3-0.5*10) -----	2
27	4PA0000313	中繼線 Connecting Cable -----	1
28	4UTD000328	端子座固定架 Terminal Holder Support -----	1
29	4PA00001111	封蓋 Rear Cover -----	1
30	-----	-----	-
31	4UTB010456	8mm空氣管接頭 Connector -----	2
32	4UTB0004321	調壓濾水閥 Regulator -----	1
33	66668	平口起子 Screwdriver -----	1
34	4UTB000434	鬆線座 Thread Pull-off Block -----	(see the table)
35	4UTB000435	導線 Thread Guide Eyelet -----	2
36	8MB03200306X	螺絲 Screw (UTB0436 M3-0.5*3) -----	2
37	4UTB00A04582	調壓濾水閥組 Regulator Asm.-----	1
38	8WD30000015B	木螺絲 Wood Screw -----	2
39	4UTB010430	空氣管 Air Tube -----	1
40	66635	六角板手 Allen Key 2MM -----	1
41	66640	六角板手 Allen Key 2.5MM -----	1
42	4UTD000343	手輪 Handwheel -----	1
43	4UTB000444	磁鐵 Magnet -----	2
44	8MN06400800A	螺絲 Screw (CT0549 M6-1*8) -----	1
45	8MN06401100C	螺絲 Screw (CT0548 M6-1*11) -----	1
46	4UTB000447	內藏式定位器 Built-in Type Synchronizer -----	1
47	8MB04280608A	螺絲 Screw (UTB0130 M4-0.7*6) -----	2
*48	4UTB02A0347	外置式定位器組 Mount- on Type Synchronizer Set-----	1
*49	/BS002	內藏式定位組 Built-in Type Synchronizer -----	1
50	4UTB02A0349	鬆線組 Thread Tension Mechanism-----	1

4. PA 鬆線機構及更換零件 PA Thread Tension Components And Motor Components

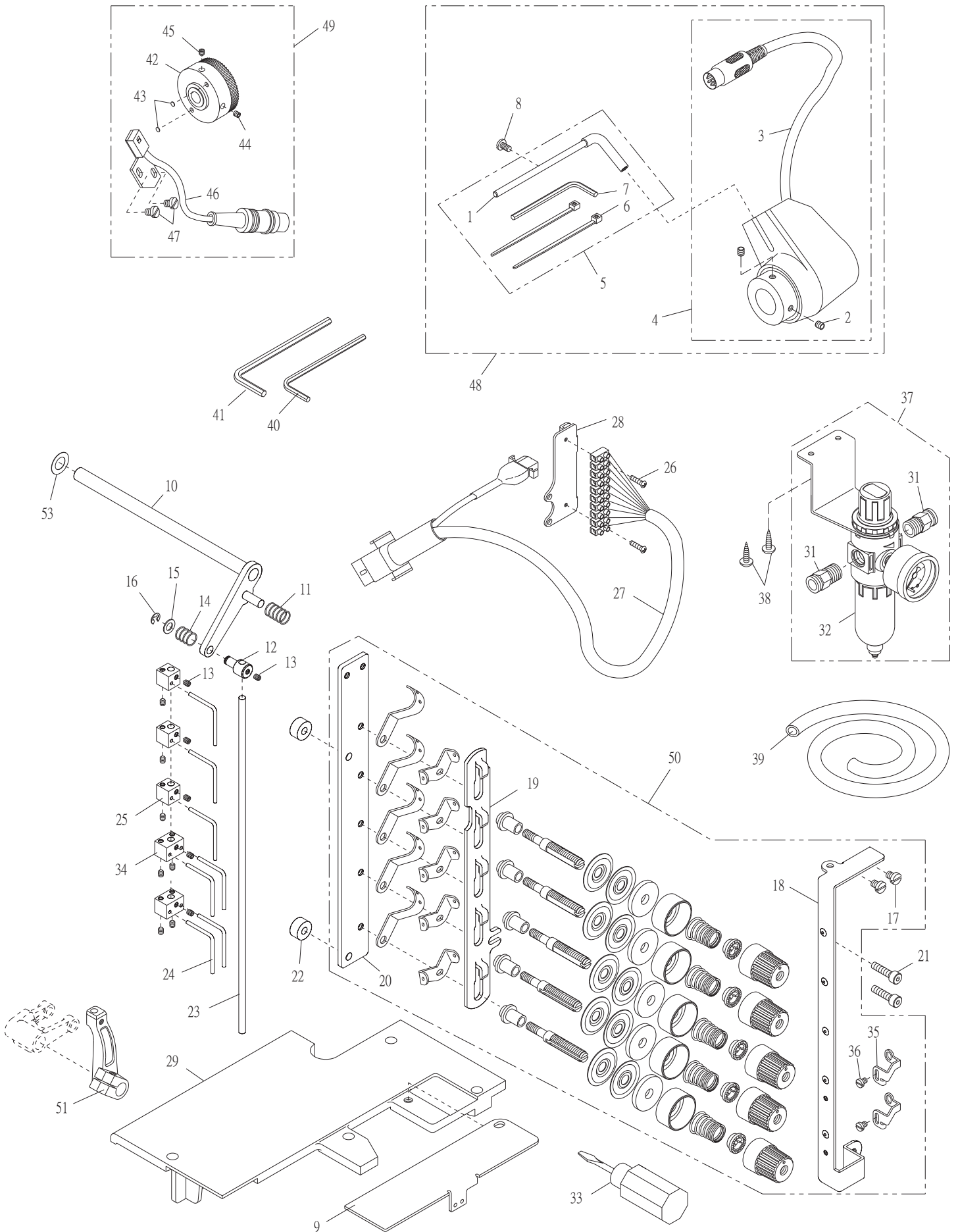

4. PA 鬆線機構及更換零件 PA Thread Tension Components And Motor Components

序號	物料編號	名稱	單位用量
Ref. No.	Parts Number	Description	Amt. Req.
51	4UTD000351	擺動臂 Rocker Arm -----	1
52	-----	-----	-
53	4UTB010459	墊圈 Washer -----	1
54	-----	-----	-

Ref. No.	13	24	25	34
2 Needle without Spreader	8pcs.	4pcs.	2pcs.	1pcs.
3 Needle without Spreader	10pcs.	5pcs.	3pcs.	1pcs.
2 Needle with Spreader	11pcs.	6pcs.	2pcs.	2pcs.
3 Needle with Spreader	13pcs.	7pcs.	3pcs.	2pcs.

- *: 選購,並須配合伺服馬達使用 <型號HVP-60,HVP-70,HVP-90>
- *: To choose and purchase: These two devices should be used together with AC servo motor <Model No:HVP-60,HVP-70,HVP-90>