

2. FT7069 / FT7069-2 上、下刀驅動機構列表

Right Hand Upper And Lower Knives Driving Mechanism Components For FT7069/FT7069-2

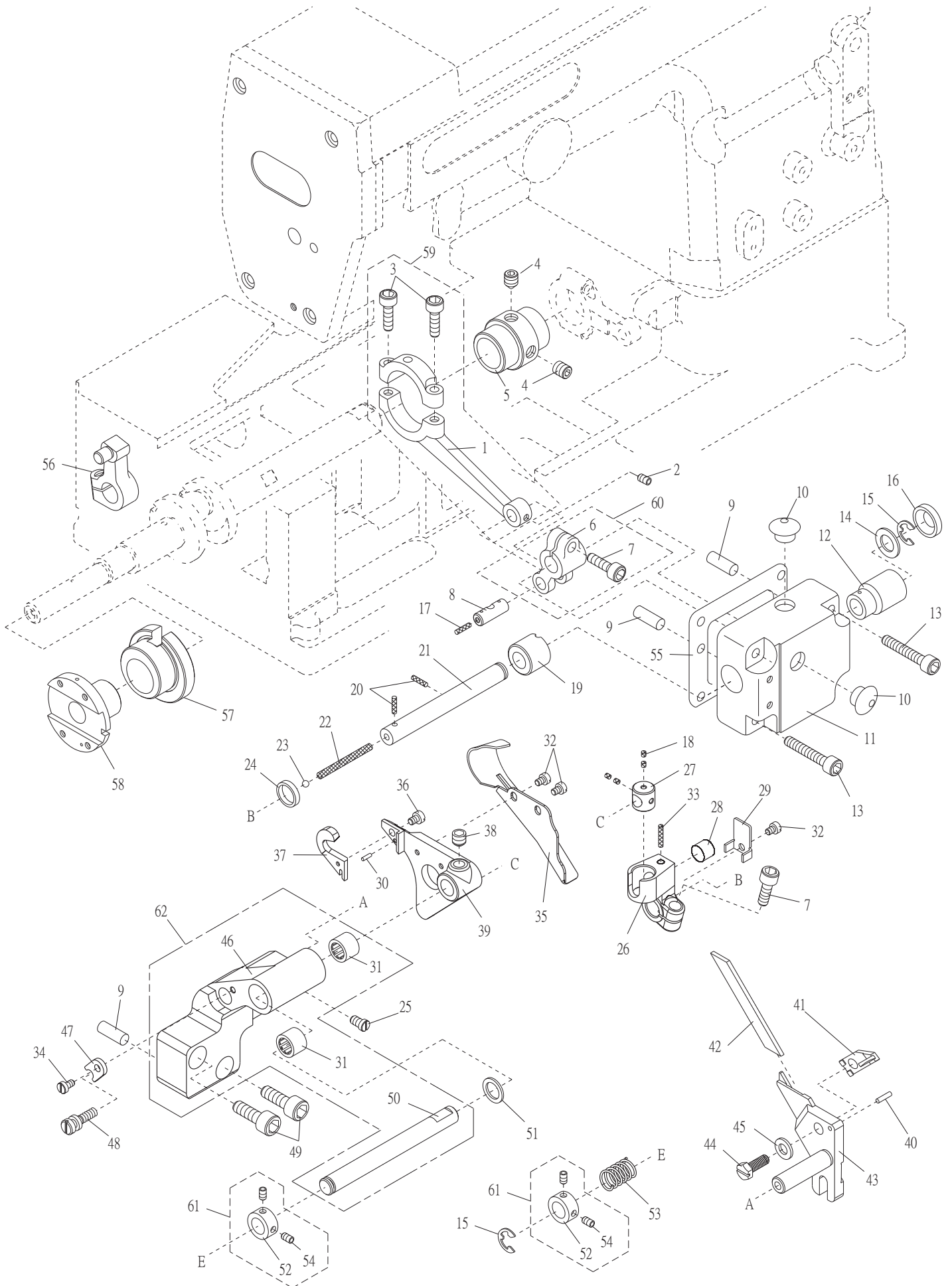

2. FT7069 / FT7069-2 上、下刀驅動機構列表

Right Hand Upper And Lower Knives Driving Mechanism Components For FT7069/FT7069-2

序號	物料編號	名稱	單位用量
Ref. No.	Parts Number	Description	Amt. Req.
1	2210090201	連桿 Connecting Rod -----	1
2	8MN03200400C	螺絲 Screw (CT1242 M3-0.5*4)-----	1
3	8MM04281407A	螺絲 Screw (FT1003 M4-0.7*14) -----	2
4	8MN05320500E	螺絲 Screw (CT0903 M5-0.8*5) -----	2
5	2210090205	偏心輪 Eccentric -----	1
6	2210090206	曲柄 Lever -----	1
7	8MM05321209A	螺絲 Screw (FT0524 M5-0.8*12) -----	2
8	2210090208	曲柄銷 Rod Pin -----	1
9	2210090209	定位銷 Knock Pin -----	3
10	22000001091	孔塞 Seal Plug -----	2
11	2210090211	軸承座 Bracket -----	1
12	2210090212	軸襯 Bushing -----	1
13	8MM04282507B	螺絲 Screw (FT0719 M4-0.7*25)-----	4
14	2210000533	墊圈 Washer -----	1
15	90ER060	E形扣環 E Ring -----	2
16	22100902161	孔塞 Plug -----	1
17	66800	油線 Oil Wick -----	4
18	66800	油線 Oil Wick -----	1
19	2210090219	軸襯 Bushing -----	1
20	66800	油線 Oil Wick -----	2
21	2210090221	軸 Shaft -----	1
22	66800	油線 Oil Wick -----	1
23	2210090223	孔塞 Plug -----	1
24	2210090224	油封 Oil Seal -----	1
25	8MB04280705K	螺絲 Screw (FT1036 M4-0.7*7)-----	1
26	2280690226	曲柄 Lever -----	1
27	2280690227	擺動軸承 Rocker Bearing-----	1
28	2280690228	羊毛氈 Felt -----	4
29	2280690229	夾簧 Latch Spring -----	1
30	90SP0105	定位銷 Knock Pin -----	1
*31	90NB0812103	滾針軸襯 Needle Bearing.-----	2
32	8MB03200405A	螺絲 Screw (FT0548 M3-0.5*4)-----	2
33	66800	油線 Oil Wick -----	1
34	8MB03200506K	螺絲 Screw (CT0525 M3-0.5*5)-----	1
35	2280690235	導布屑 Chip Guard -----	1
36	8SB32440604K	螺絲 Screw (FT70690236 1/8"-44*5.5)-----	1
37	22806902372	上刀 Upper Knife -----	1
38	8MN06400500A	螺絲 Screw (C0513 M6-1*5)-----	1
39	2280690239	上刀座 Upper Knife Holder -----	1
40	90SP0208	定位銷 Knock Pin -----	1
41	2210090241	壓板 Lower Knife Clamp -----	1
42	2210090242	下刀 Lower Knife -----	1
43	2280690243	下刀座 Lower Knife Holder -----	1
44	8SK44401207A	螺絲 Screw (FT70690244 11/64"-40*12)-----	1
45	2100000526	墊圈 Washer -----	1
*46	2280690246	下刀台 Lower Knife Holder Bracket -----	1
47	2280690247	止動片 Rotation Stopper -----	1
48	2280690248	螺樁 Stud -----	1
49	8MM06402010A	螺絲 Screw (SH0444 M6-1*20)-----	2
*50	2280690250	軸 Shaft -----	1

2. FT7069 / FT7069-2 上、下刀驅動機構列表

Right Hand Upper And Lower Knives Driving Mechanism Components For FT7069/FT7069-2

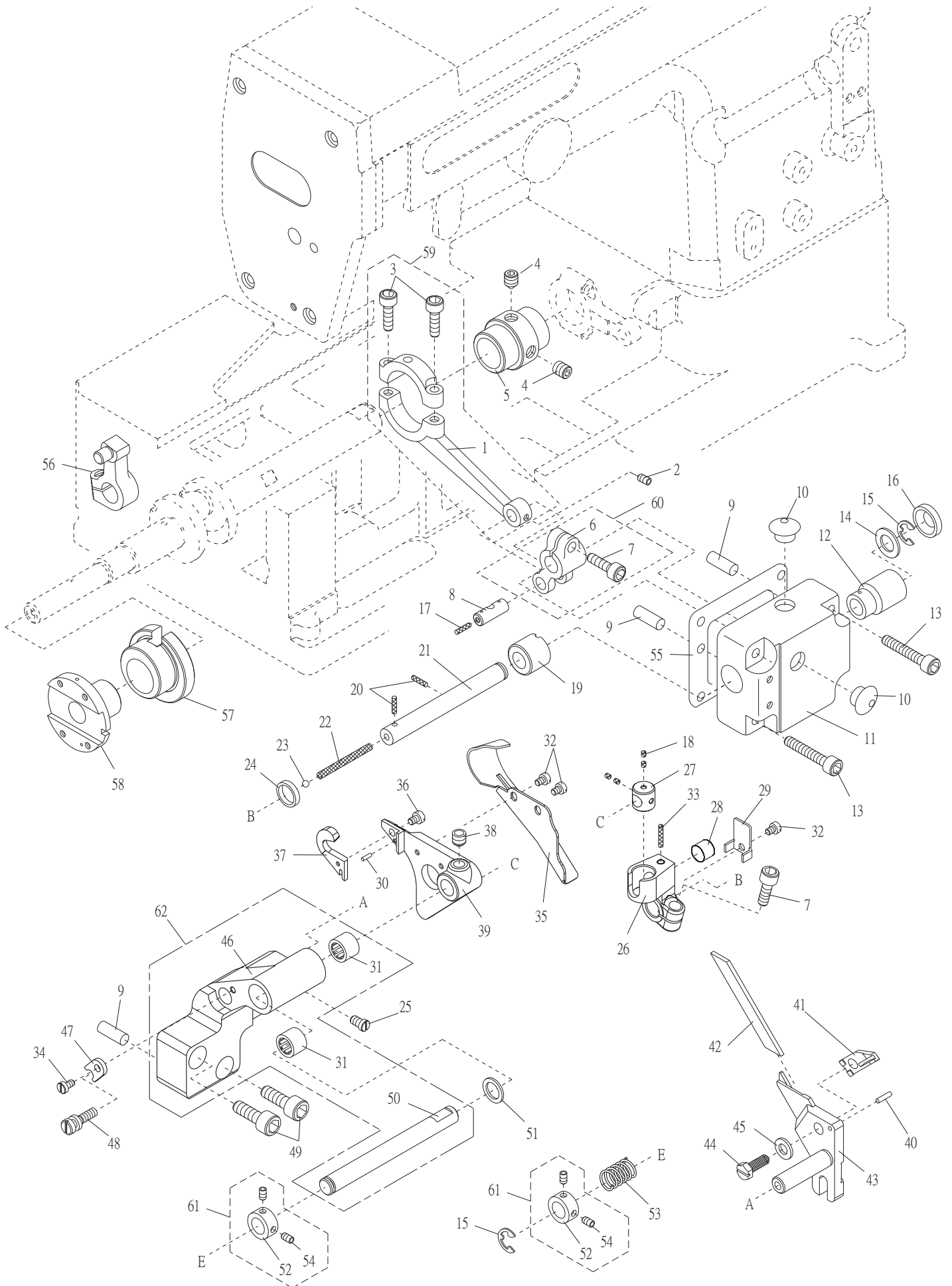

2. FT7069 / FT7069-2 上、下刀驅動機構列表

Right Hand Upper And Lower Knifes Driving Mechanism Components For FT7069/FT7069-2

序號	物料編號	名稱	單位用量
Ref. No.	Parts Number	Description	Amt. Req.
51	2280690251	墊圈 Washer -----	1
52	2210000534	定位環 Collar -----	2
53	2280690253	彈簧 Spring -----	1
54	8MN03200300A	螺絲 Screw (C0115 M3-0.5*3)-----	4
55	2210090255	油封 Gasket -----	1
56	2210390256	曲柄 Lever -----	1
57	2210600135	變距偏心輪 Regulating Eccentric (FT600135)-----	1
58	2210600136	進給偏心輪 Eccentric(FT600136) -----	1
59	221A0090256	連桿組 Connecting Rod Asm.-----	1
60	221A0090257	曲柄組 Lever Asm.-----	1
61	221A0000563	定位環組 Collar Asm. -----	2
62	228A0690262	刀台組 Bracket ASM. -----	1

* : 需整組購買 Must be sold in complete set