

3. FT7069 / FT7069-1 送鬆緊帶傳送機構列表 (A)
 Metering Device Mechanism Components (A) For FT7069 / FT7069-1

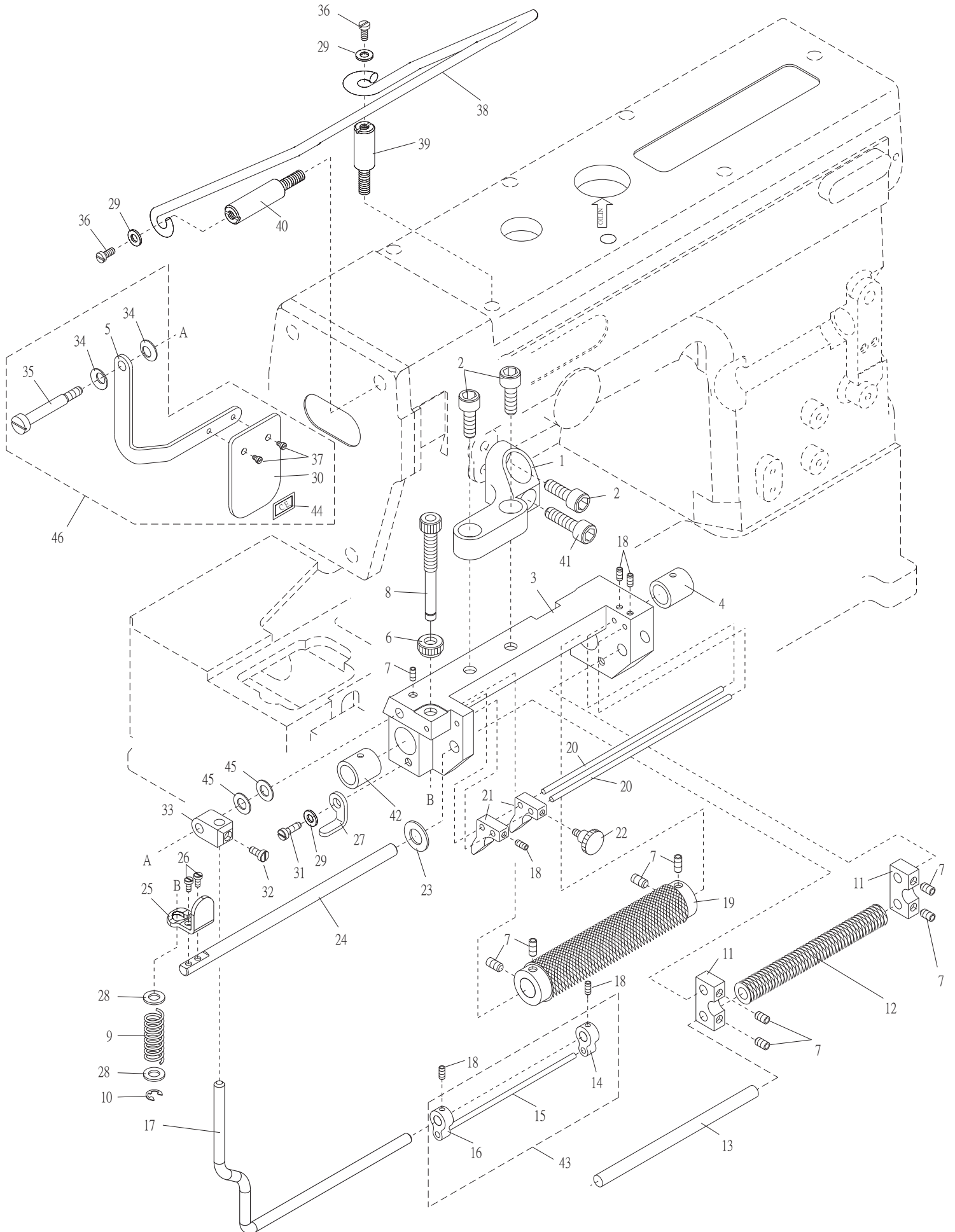

3. FT7069 / FT7069-1 送鬆緊帶傳送機構列表 (A)

Metering Device Mechanism Components (A) For FT7069 / FT7069-1

序號	物料編號	名稱	單位用量
Ref. No.	Parts Number	Description	Amt. Req.
1	2210390301	支架 Roller Holder Bracket -----	1
2	8MM06401610A	螺絲 Screw (CT0625 M6-1*16)-----	3
3	2280690303	滾輪支架 Roller Holder -----	1
4	2210090304	軸襯 Bushing -----	1
5	2210390305	護目鏡架 Safety Plate Holder -----	1
6	2280690306	調整螺帽 Adjusting Nut -----	1
7	8MN04280400A	螺絲 Screw (CT0229 M4-0.7*4)-----	9
8	2280690308	調節螺樁 Stud -----	1
9	2280690309	彈簧 Spring -----	1
10	90ER040	E型扣環 E-Ring -----	1
11	2210090311	從動滾輪臂 Arm -----	2
12	2210090312	從動滾輪 Tension Roller -----	1
13	2210090313	軸 Shaft -----	1
14	2210090314	右導模 Tape Guide(R) -----	1
15	2210090315	導模滑桿 Tape Guide Bar -----	1
16	2210090316	左導模 Tape Guide(L) -----	1
17	2280690317	導模承桿 Tape Guide Support Bar -----	1
18	8MN03200300A	螺絲 Screw (CT0115 M3-0.5*3)-----	5
19	2210090319	主動滾輪 Feeding Roller -----	1
20	2210090320	導模導桿 Tape Guide Bar -----	2
21	2280690321	導模 Tape Guide -----	2
22	2210090322	固定螺樁 Knob Screw Stud -----	1
23	2200000910	墊圈 Washer -----	1
24	2280690324	軸 Tension Link Shaft -----	1
25	2280690325	釋壓板手 Press Release -----	1
26	8MB03200606K	螺絲 Screw (CT1207 M3-0.5*6)-----	2
27	2280690327	限位片 Holder -----	1
28	2200001025	墊圈 Washer -----	2
29	2100000223	墊圈 Washer (W3)-----	3
30	2200001622	護目鏡 Safety Plate -----	1
31	8MB04281007K	螺絲 Screw (CT1237 M4-0.7*10)-----	1
32	8SB48280808A	螺絲 Screw (S0119 3/16"-28*8)-----	1
33	2210090333	接頭 Joint -----	1
34	2200000228	彈簧墊圈 Conical Spring Washer (CT0228)-----	2
35	8MB04283809E	螺樁 Stud (CT0227 M4-0.7*38)-----	1
36	8MC04281207D	螺絲 Screw(CT0102 M4-0.7*12)-----	2
37	8MB03200405A	螺絲 Screw (FT0548 M3-0.5*4)-----	2
38	4TB0000101	帶架 Tape Holder (FTB0101)-----	1
39	2210600116	螺樁 Stud (FT600116)-----	1
40	4TB0000103	螺樁 Stud (FTB0103)-----	1
41	8MM06402010A	螺絲 Screw (SH0444 M6-1*20)-----	1
42	2210390342	軸襯 Bushing -----	1
43	221A0090341	導模滑桿組 Tape Guide Bar Asm.-----	1
44	66451	貼紙 Paster -----	1
45	2200001025	墊圈 Washer -----	2
46	221A0390346	護目鏡組 Safety Plate Asm.-----	1

4. FT7069 / FT7069-1 送鬆緊帶傳送機構列表 (B)
Metering Device Mechanism Components (B) For FT7069 / FT7069-1

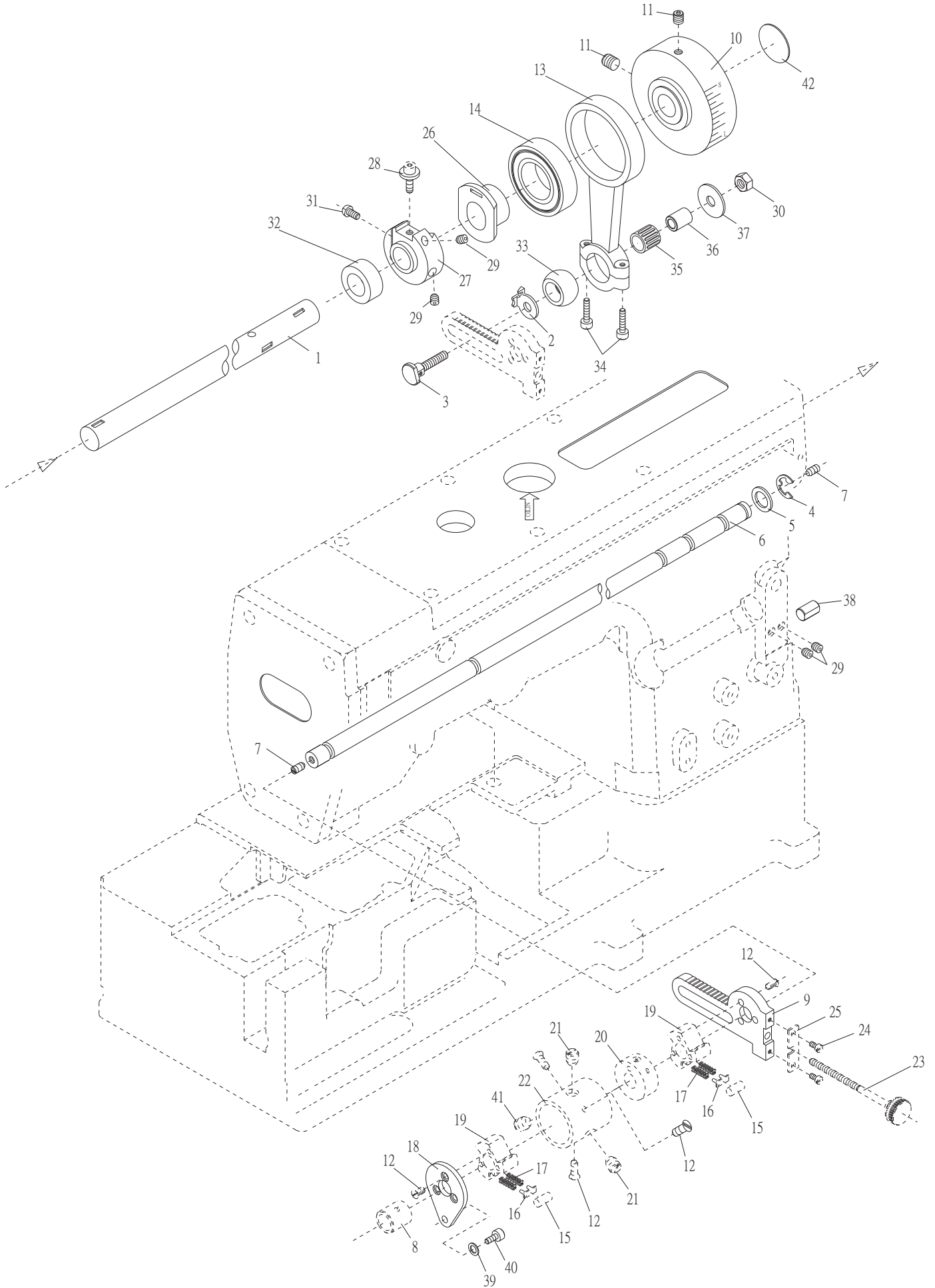

4. FT7069 / FT7069-1 送鬆緊帶傳送機構列表 (B)

Metering Device Mechanism Components (B) For FT7069 / FT7069-1

序號	物料編號	名稱	單位用量
Ref. No.	Parts Number	Description	Amt. Req.
1	2210390401	軸 Roller Shaft -----	1
2	2210390402	指標墊圈 Pointer -----	1
3	2210390403	連桿銷 Connect Pin -----	1
4	90ER080	E形扣環 E Ring -----	1
5	2210390405	墊圈 Washer -----	1
6	22806904061	軸 Shaft -----	1
7	8MN06400500A	螺絲 Screw (C0513 M6-1*5) -----	2
8	2210090408	軸襯 Bushing -----	1
9	2210390409	離合器連桿 Clutch Lever -----	1
10	2210390410	手輪 Handwheel -----	1
11	8MN06400800A	螺絲 Screw (CT0549 M6-1*8) -----	2
12	8SF36400606A	螺絲 Screw (RP0217 9/64"-40*7) -----	9
13	2210390413	連桿 Rod -----	1
14	90BB2547127	滾珠軸承 Bearing -----	1
15	4RP0010225	離合器滾柱 Clutch Roller -----	6
16	4RP0010224	滾柱承座 Clutch Roller Base -----	6
17	4RP0010223	彈簧 Clutch Spring -----	12
18	2210390418	離合器制動板 Clutch Plate -----	1
19	4RP0010221	離合器 Clutch -----	2
20	2210090420	內環 Clutch Sleeve Collar -----	1
21	8MN06400800A	螺絲 Screw (CT0549 M6-1*8) -----	2
22	2210090422	外環 Clutch Sleeve -----	1
23	2210090423	調整螺絲 Adjusting Screw -----	1
24	8MB03200606K	螺絲 Screw (CT1207 M3-0.5*6) -----	2
25	2210390425	止動片 Stopper -----	1
26	2210390426	滑塊 Upper Feed Roller Eccentric -----	1
27	4RP0010323	滑軌 Upper Feed Roller Regulator -----	1
28	2210390428	調整螺絲 Adjusting Screw -----	1
29	8MN05320500E	螺絲 Screw (CT0903 M5-0.8*5) -----	4
30	2210390430	螺帽 Nut -----	1
31	8MB04280807K	螺絲 Screw (CTS0215 M4-0.7*8) -----	1
32	2210390432	隔環 Spacer -----	1
33	2210390433	萬向肘 Ball -----	1
34	2210390434	螺絲 Screw -----	1
35	90NB101313	滾針軸承 Needle Bearing -----	1
36	2210390436	襯套 bushing -----	1
37	2210390437	墊圈 Washer -----	1
38	2210390438	懸臂軸 Shaft -----	1
39	2100000223	墊圈 Washer (W3) -----	1
40	8MM04281007A	螺絲 Screw (FT0203 M4-0.7*10) -----	1
41	8MN06400400A	螺絲 Screw (FT390441 M6-1*4) -----	1
42	66480-11	銘板 Plate -----	1