

4. UTE07 電控式組件 UTE07 Electric Type Components

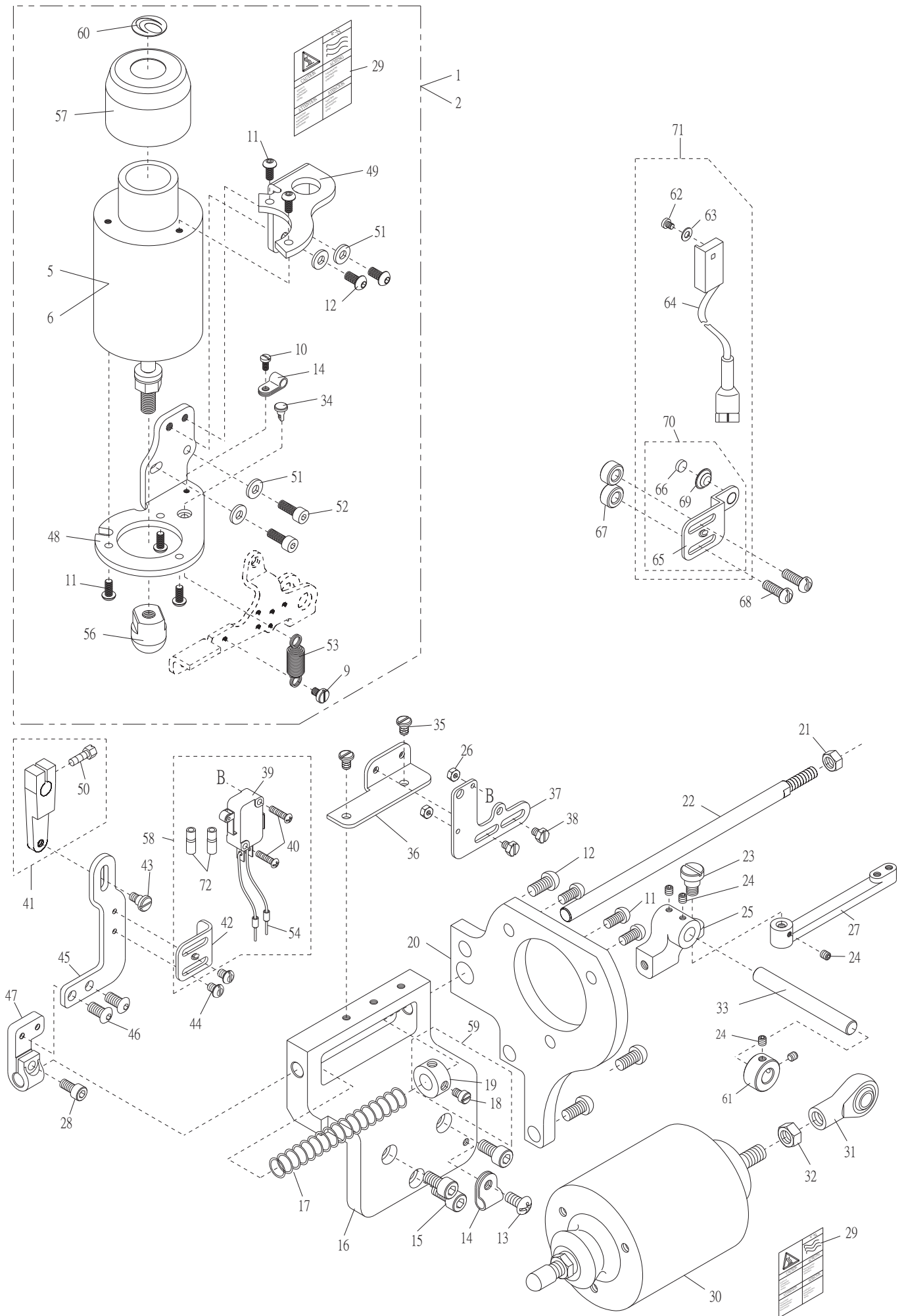

4.UTE07 電控式組件UTE07 Electric Type Components

序號	物料編號	名稱	單位用量
Ref. No.	Parts Number	Description	Amt. Req.
*1	PFE2P	壓腳提昇組 Presser Foot Lifter,C.Set -----	1
2	PFE02	壓腳提昇組 Presser Foot Lifter,C.Set -----	1
3	-----	-----	-
4	-----	-----	-
5	4PFE010101	磁力線圈 Presser Foot Lifter Solenoid -----	1
*6	4PFE1P0121	磁力線圈 Presser Foot Lifter Solenoid -----	1
7	-----	-----	-
8	-----	-----	-
9	8MB05320710G	螺絲 Screw (PFE020116 M5-0.8*7) -----	1
10	8MC04280807A	螺絲 Screw (CT0120 M4-0.7*8) -----	1
11	8MP05321210A	螺絲 Screw (UTB0340 M6-1*11.5) -----	8
12	8MP06401211A	螺絲 Screw (UTB0302 M6-1*12) -----	5
13	8MC04280807D	螺絲 Screw (CT0130 M4-0.7*8) -----	2
14	4UTD000254	線夾 Cord Clamp -----	2
15	8MM06401210A	螺絲 Screw (FT1103 M6-1*12) -----	3
16	4UTD000252	空壓組件座 Trimming Cylinder Support-----	1
17	4UTC000112	彈簧 Spring -----	1
18	8MC95300606F	螺絲 Screw (CT0823 M4.5-0.75*5) -----	1
19	4UTB010245	定位環 Collar -----	1
20	4UTE0001201	磁力線圈座 Solenoid Barcket -----	1
21	8MA08500513A	螺帽 Nut (FTC10126 M8-1.25*5) -----	1
22	4UTD000222	軸 Shaft -----	1
23	4UTD000223	螺樁 Stud -----	1
24	8MN04280400A	螺絲 Screw (CT0229 M4-0.7*4) -----	5
25	4UTE000125	承座 Plunger -----	1
26	8MA03200306A	螺帽 Nut (FTB0111 M3-0.5*3) -----	2
27	4UTD0002271	連結桿 Connecting Rod -----	1
28	8MM05321209A	螺絲 Screw (FT0524 M5-0.8*12) -----	1
29	4UTC000139	貼紙 Paster-----	2
30	4UTC0001301	磁力線圈 Solenoid -----	1
31	4UTB010326	球軸連桿 Plunger Connecting Rod -----	1
32	8MA08500613A	螺帽 Nut (RP10208 M8-1.25*6) -----	1
33	4UTC0001251	軸 Shaft -----	1
34	4PFE020102	接頭 Joint -----	1
35	8MB04280607K	螺絲 Screw (MT0223 M4-0.7*6) -----	2
36	4UTD030203	基板 Base -----	1
37	4UTC020114	安全開關座 safety Switch Bracket -----	1
38	8MK04280507A	螺絲 Screw (WPC0106 M4-0.7*5) -----	2
39	4UTB000336	安全開關 Safety Switch -----	1
40	8MC03201606D	螺絲 Screw (UTB03351 M3-0.5*16) -----	2
41	4UTB010337	曲柄 Tension Release Lever -----	1
42	4UTB020212	擋片 Stopper -----	1
43	8MB04280908G	螺樁 Stud (UTB0339 M4-0.7*8) -----	1
44	8MB04280507K	螺絲 Screw (FT0235 M4-0.7*5) -----	2
45	4UTD020245	連桿 Connecting Plate -----	1
46	8MP05320810A	螺絲 Screw (STB0117 M5-0.8*8) -----	2
47	4UTD020247	連結塊 Connecting Block -----	1
48	4PFE020103	磁力線圈固定座 Bracker -----	1
49	4PFE020104	固定座 Bracker -----	1
50	8MK95301407A	螺絲 Screw (CT0837 M4.5-0.75*14) -----	1

4. UTE07 電控式組件 UTE07 Electric Type Components

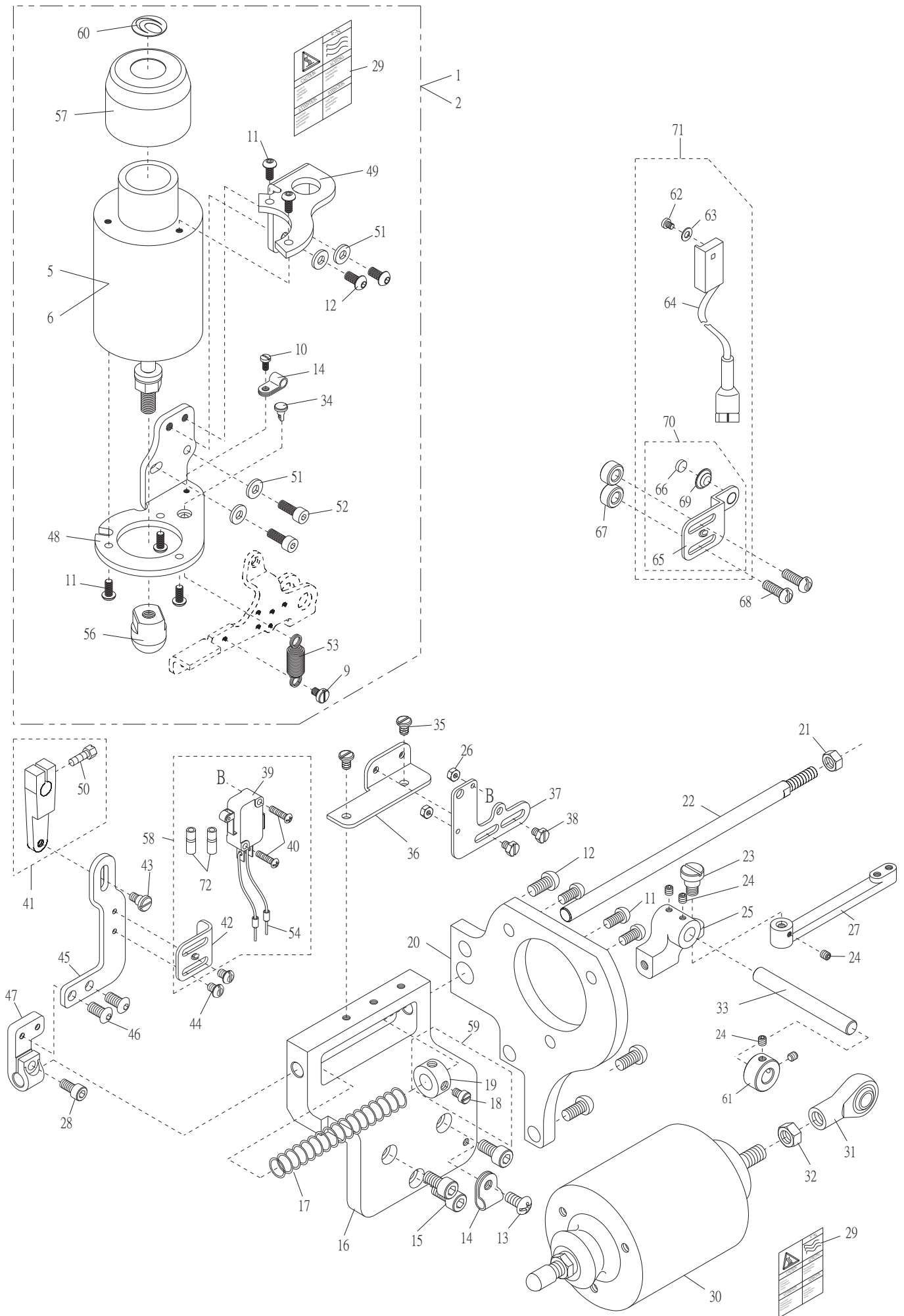

4.UTE07 電控式組件UTE07 Electric Type Components

序號	物料編號	名稱	單位用量
Ref. No.	Parts Number	Description	Amt.Req.
51	2100000323	墊圈 Washer (SH0323) -----	4
52	8MM06401610A	螺絲 Screw (CT0625 M6-1*16) -----	2
53	4PFE010106	彈簧 Spring -----	1
54	4UTB020272	公端子 Power cord -----	2
55	-----	-----	-
56	4PFE010113	套管 Clutch Sleeve -----	1
57	4PFE010119	護蓋 Cover -----	1
58	4UTB02A0255	觸控支架組 One Touch Type Safety Switch SET. -----	1
59	4UTB01A0255	定位環組 Collar Asm.-----	1
60	66480-11	銘板 Plate -----	1
61	4UTB010152	定位環 Collar -----	1
*62	8SB44400507A	螺絲 Screw -----	1
*63	2200001025	墊圈 Washer -----	1
*64	4UTB020256	安全開關 Safety Switch -----	1
*65	4UTB020259	支架 Knife Holder Bracket -----	1
*66	4UTB000444	磁鐵 Magnet -----	1
*67	2200001141	隔環 Spacer -----	2
*68	8MB04281207K	螺絲 Screw (CT0239 M4-0.7*12) -----	2
*69	4UTB020250	銅扣 Brass Button -----	1
*70	4UTB02A0249	支架組 Knife Holder Bracket Asm.-----	1
*71	4UTB02A0253	磁控支架組 Magnetic Type Safety Switch SET. -----	1
72	4UTB020228	絕緣套管 Bushing -----	2

* 配合RP使用

* 磁控支架組用 For Magnetic Type Safety Switch SET

*須配合伺服馬達使用 (型號 : HVP-60,HVP-70)

Should be used together with AC servo motor (Model : HVP-60,HVP-70)