

副機型專用零件 NT67-01M5 NT67-01M6

NT67-01M5 專用零件  
NT67-01M5 Exclusive Parts

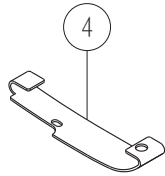

NT67-01M6 專用零件  
NT67-01M6 Exclusive Parts

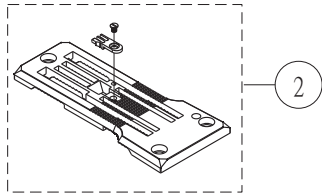
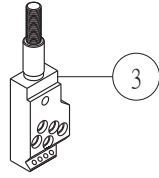
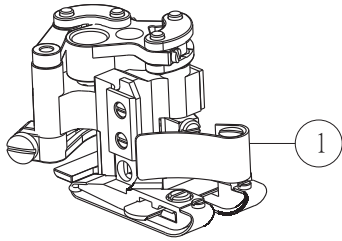
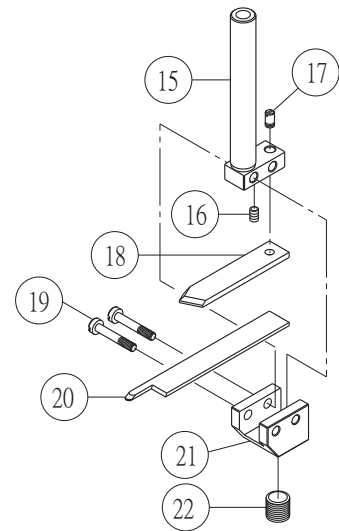
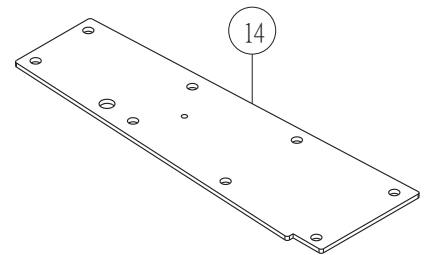
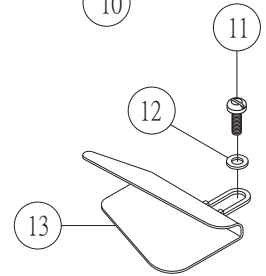
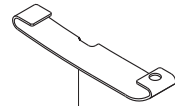
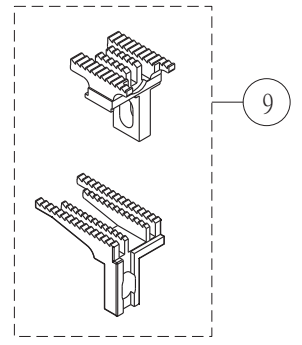
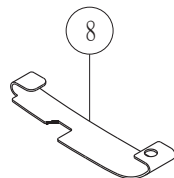
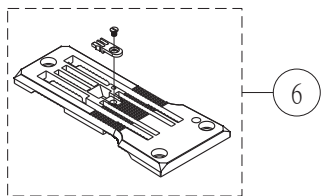
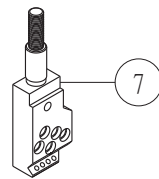
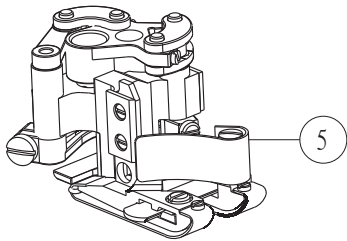

NT67-01M5專用零件 NT67-01M5 Exclusive Parts

序號	物料編號	名稱		單位用量
Ref. No.	Parts Number	Description		Amt.Req.
1	5240PF02	壓腳組	Presser Foot Asm.	1
2	5240TP003	針板組	Stitch Plate Asm.	1
3	5240NC0013	針留	Needle	1
4	5240PF0214	簧片補助壓腳底	Presser Foot Spring Plate	1

NT67-01M6專用零件 NT67-01M6 Exclusive Parts

序號	物料編號	名稱		單位用量
Ref. No.	Parts Number	Description		Amt.Req.
5	5240PF04	壓腳組	Presser Foot Asm.	1
6	5240TP004	針板組	Stitch Plate Asm.	1
7	5240NC0023	針留	Needle	1
8	5240PF0224	簧片補助壓腳底	Presser Foot Spring Plate	1

NT67-01M5 / NT67-01M6

序號	物料編號	名稱		單位用量
Ref. No.	Parts Number	Description		Amt.Req.
9	5240DG02	送布齒組	Feed Dog Asm.	1
10	5240PF0215	簧片補助壓腳底	Presser Foot Spring Plate	1
11	8MB85241107A	螺絲	Screw	1
12	2100000223	墊圈	Washer	1
13	668591	導模	Lap Former	1
14	2400010811	送齒台架封蓋	Sewing Cylinder Cover	1
15	240010021	刀柄	Knife	1
16	8SG24560400A	螺絲	Screw	1
17	8SB24560302M	螺椿	Screw	1
18	240010010	壓板	Knife	1
19	8SB24561304B	螺絲	Screw	2
20	240010009	刀片	Upper Knife	1
21	240010008	刀片夾	Upper Holder	1
22	8SN64400600A	螺絲	Screw	1