

電磁式壓腳提昇裝置 / PFE05 For TTS34 Elec-Magnetic Presser Foot Lifter

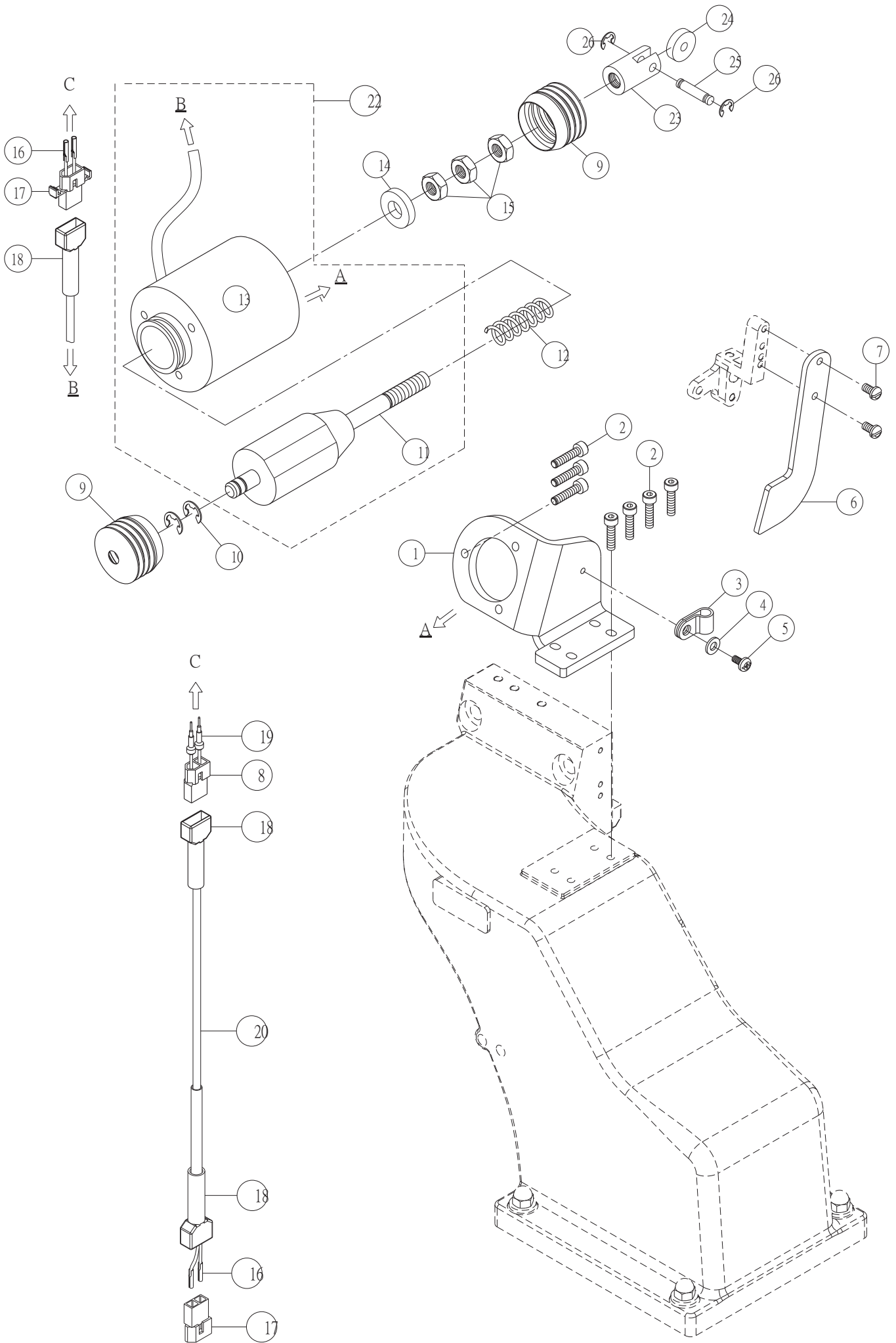

電磁式壓腳提昇裝置 /PFE05 For TTS34 Elec-Maghetic Presser Foot Lifter

序號	物料編號	名稱		單位用量
Ref. No.	Parts Number	Description		Amt.Req.
1	4PFE050114	支架	Bracket	1
2	8MM05321409X	螺絲	Screw	7
3	4PFE040103	管夾	Thread Pipe Stay	1
4	2100000223	墊圈	Washer	1
5	8MC04280607D	螺絲	Screw	1
6	4PFE050115	壓桿	Bracket	1
7	8SB48321008A	螺絲	Screw	2
8	4PFE040107	2PIN 公扣連接器	Power Cord	1
9	4PFE050107	橡膠套	Cap	2
10	90ER070	E 型扣環 (E7)	E Ring	2
11	4PFE050102	磁力線圈心軸	Shaft	1
12	4PFE050106	彈簧	Spring	1
13	4PFE050101	磁力線圈	Presser Foot Lifter Solenoid	1
14	4PFE050105	橡膠墊	Washer	1
15	8MA08500413A	螺帽	Nut	3
16	4AL013015	端子	Power Cord	4
17	4AL013017	2PIN 母扣連接器	Power Cord	2
18	4AL013013	2PIN 連接器套頭	Power Cord Cap	3
19	4PFE040108	端子	Power Cord	2
20	4AL013018	電線	Cable 1150L	1
22	4PFE05A0101	磁力線圈組	Presser Foot Lifter Solenoid Asm.	1
23	4PFE050111	接頭	Clutch Sleeve	1
24	4PFE050110	滾輪	Pulley	1
25	4PFE050112	軸	Pin	1
26	90ER030	E 型扣環 (E3)	E Ring	2