

1.PMD01/PMD02 下送式送料装置Metering Device Mechanism For PMD01//PMD02

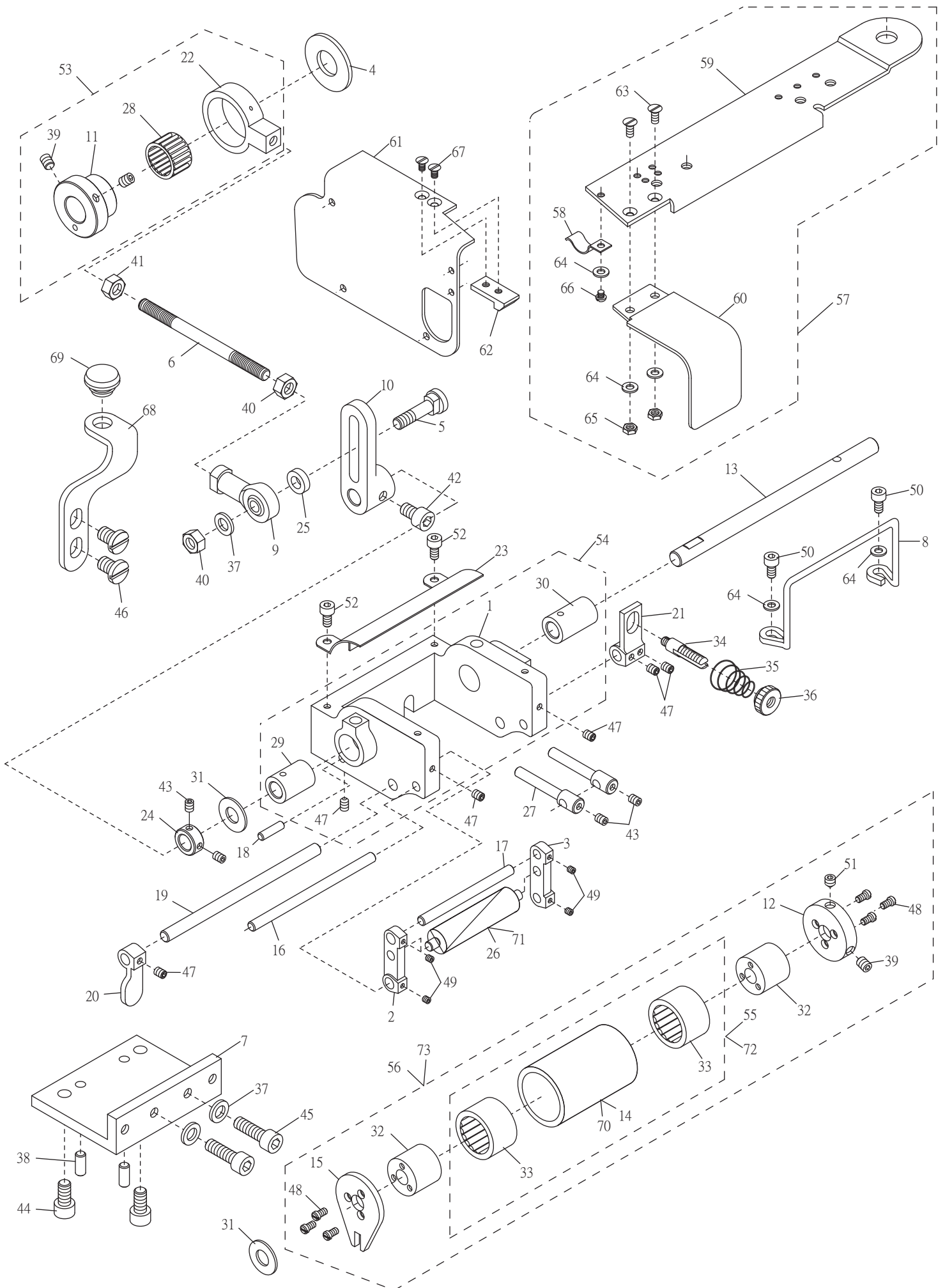

1.PMD01/PMD02 下送式送料裝置Metering Device Mechanism For PMD01//PMD02

序號	物料編號	名稱	單位用量
Ref. No.	Parts Number	Description	Amt. Req.
1	4PMD010101	滾輪底座Bracket -----	1
2	4PMD010102	左連桿Link (Left) -----	1
3	4PMD010103	右連桿Link (Right) -----	1
4	4PMD010104	墊圈Washer -----	1
5	4PMD010105	螺樁Stud -----	1
6	4PMD010106	螺樁Stud -----	1
7	4PMD010107	定位塊Bracket -----	1
8	4PMD010108	支架Holder Bracket -----	1
9	4PMD010109	球軸連桿Ball Link -----	1
10	4PMD010110	連結塊Connection Block -----	1
11	4PMD010111	偏心輪Eccentric -----	1
12	4PMD010112	封蓋Cover -----	1
13	4PMD010113	軸Shaft -----	1
*14	4PMD010114	主動滾輪Up Feed Roller -----	1
15	4PMD010115	封蓋Cover -----	1
16	4PMD010116	軸Shaft -----	1
17	4PMD010117	軸Shaft -----	1
18	4PMD010118	銷Pin -----	1
19	4PMD010119	軸Shaft -----	1
20	4PMD010120	釋壓板手Press Release -----	1
21	4PMD010121	調壓臂Spring Holder -----	1
22	4PMD010122	連桿Link -----	1
23	4PMD010123	檔片Chain-off Guide -----	1
24	4PMD010124	定位環Collar -----	1
25	4PMD010125	墊圈Washer -----	1
*26	4PMD010126	從動滾輪Lower Feed Roller -----	1
27	4PMD010127	軸Shaft -----	2
28	90NB222610	軸承Bearing (SH0516)-----	1
29	4PMD010129	軸襯Bushing -----	1
30	4PMD010130	軸襯Bushing -----	1
31	2310001301	墊圈Washer -----	2
32	2310001304	離合器Clutch -----	2
33	90NB2026161	單向滾針軸承Needle Bearing (RP1A0219)-----	2
34	2210090308	調節螺樁Adjusting Stud (F090308)-----	1
35	4PMD010135	彈簧Spring -----	1
36	2100051134	調節螺帽Adjusting Nut (SH11-34)-----	1
37	2100000323	墊圈Washer (SH0323)-----	3
38	4RP0010103	銷Pin (RP10103) -----	2
39	8MN05320600A	螺絲Screw (MT0729 M5-0.8*6) -----	2
40	8MA06400510A	螺帽Nut (CT0533 M6-1*5) -----	2
41	8MA06400510B	左旋螺帽Nut (MT1641 M6-1*5) -----	1
42	8MM06401010A	螺絲Screw (MT0419 M6-1*10) -----	1
43	8MN04280500A	螺絲Screw (MT1334 M4-0.7*5) -----	4
44	8MM06401210A	螺絲Screw (FT1103 M6-1*12) -----	2
45	8MM06402010A	螺絲Screw (SH0444 M6-1*20) -----	2
46	8MB04280607K	螺絲Screw (MT0233 M4-0.7*6) -----	2
47	8MN04280400A	螺絲Screw (CT0229 M4-0.7*4) -----	6
48	8SB32440604A	螺絲Screw (MT1332 1/8"-44*6) -----	6
49	8MN03200300A	螺絲Screw (CT0115 M3-0.5*3) -----	4
50	8MM04281007A	螺絲Screw (FT0203 M4-0.7*10) -----	2

1.PMD01/PMD02 下送式送料装置Metering Device Mechanism For PMD01//PMD02

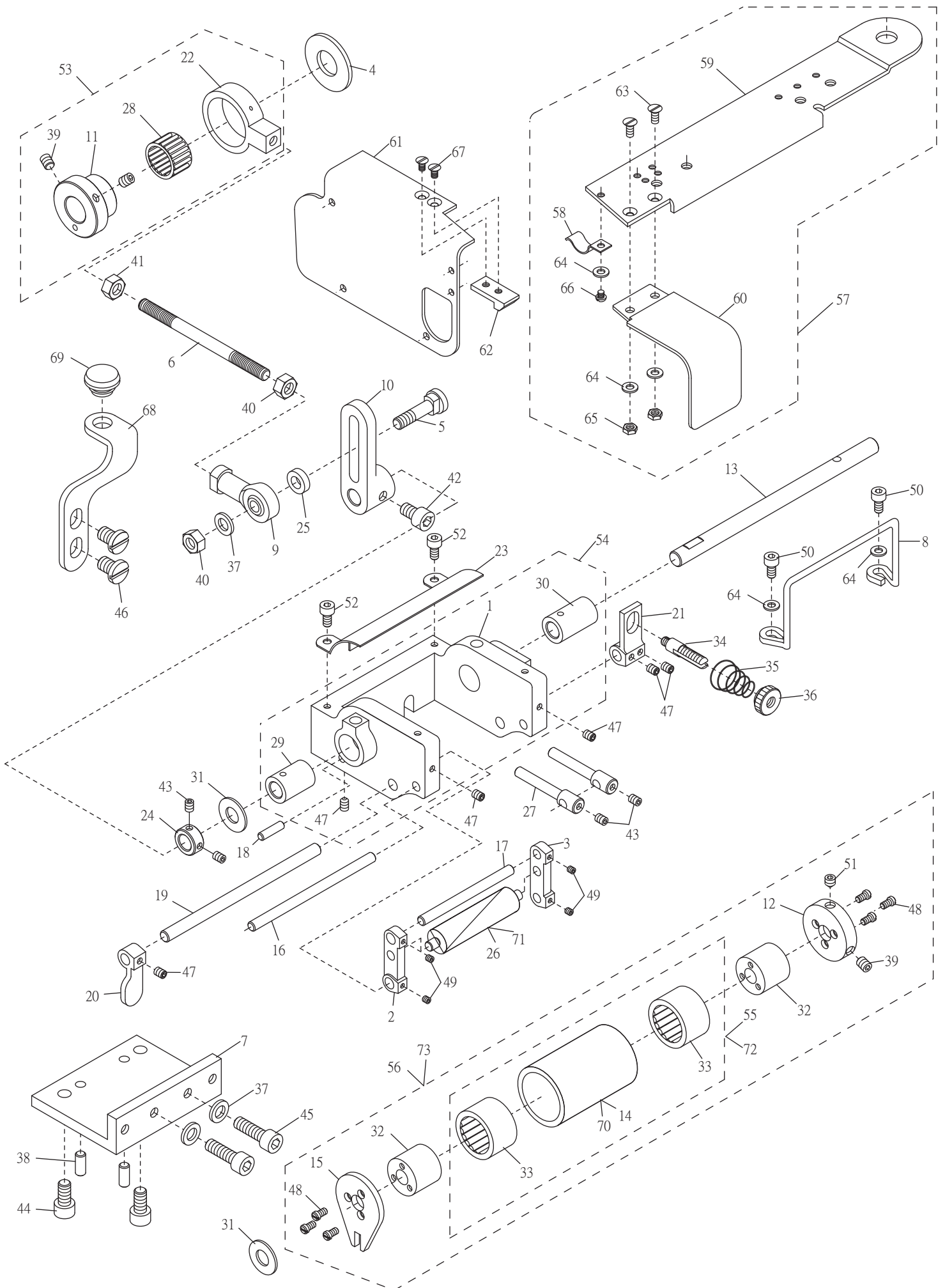

1.PMD01/PMD02 下送式送料裝置Metering Device Mechanism For PMD01//PMD02

序號 Ref. No.	物料編號 Parts Number	名稱 Description	單位用量 Amt.Req.
51	8MN05320600C	螺絲Screw (C350248 M5-0.8*6) -----	1
52	8MM04280607A	螺絲Screw (MT1134 M4-0.7*6) -----	2
53	4PMD01A0153	偏心輪組Eccentric Asm. -----	1
54	4PMD01A0154	滾輪底座組Bracket Asm. -----	1
*55	4PMD01A0155	主動滾輪組Feed Roller Asm. -----	1
*56	4PMD01A0156	離合器組Clutch Asm. -----	1
57	4PMD01A0157	下座外蓋組Cloth Plate Asm.-----	1
58	4PMD010158	簧片Spring -----	1
59	4PMD010159	下座外蓋Cloth Plate -----	1
60	4PMD010160	下座前蓋Cover -----	1
61	4PMD010161	下座外蓋Cloth Plate -----	1
62	4PMD010162	固定座Bracket -----	1
63	8ME04281008A	螺絲Screw (FT0218 M4-0.7*10) -----	2
64	2100000223	墊圈Washer (SH0223)-----	5
65	8MA04280307A	螺絲Screw (CT0238 M4-0.7*3) -----	2
66	8MB85240406K	螺絲Screw (PMD010166 M3.5-0.6*4) -----	1
67	8ME04280708A	螺絲Screw (CT0206 M4-0.7*7) -----	2
68	4PMD010168	固定座Bracket -----	1
69	2100001213	防震墊Rubber Plug -----	1
**70	4PMD010170	主動滾輪Up Feed Roller (優力膠平輪) -----	1
**71	4PMD010171	從動滾輪Lower Feed Roller (優力膠平輪) -----	1
**72	4PMD01A0172	主動滾輪組Feed Roller Asm. -----	1
**73	4PMD01A0173	離合器組Clutch Asm. -----	1

* :壓花滾輪用於PMD01

** :平輪無壓花用於PMD02