

1. TC002 / TCS02 / TC005 / TCS05 電動式切帶裝置  
TC002 / TCS02 / TC005 / TCS05 Electric Type Tape Cutting Device

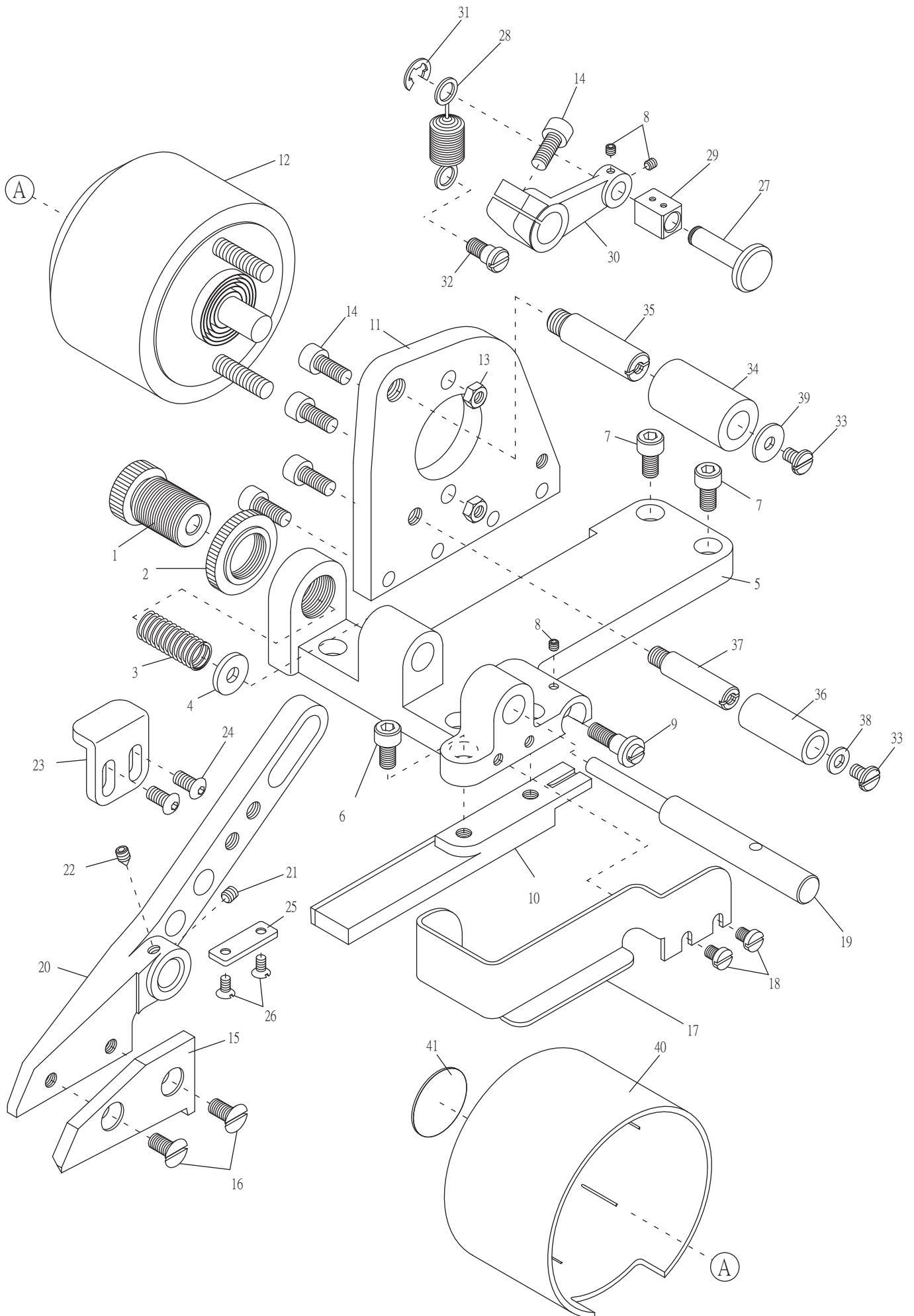

1. TC002 / TCS02 / TC005 / TCS05 電動式切帶裝置

TC002 / TCS02 / TC005 / TCS05 Electric Type Tape Cutting Device

序號	物料編號	名稱	單位用量
Ref. No.	Parts Number	Description	Amt. Req.
1	4TC0010101	壓力調整螺樁 Spring Regulator -----	1
2	4TC0010102	螺樁 Stud -----	1
3	4TC0010103	彈簧 Spring -----	1
4	2200000627	墊圈 Washer -----	1
5	4TC0020105	刀座 Cutting Device Basement -----	1
6	8MM05320809A	螺絲 Screw (CT1145 M5-0.8*8) -----	2
7	8MM05321009A	螺絲 Screw (CT0626 M5-0.8*10) -----	4
8	8MN03200300A	螺絲 Screw (CT0115 M3-0.5*3) -----	3
9	4TC0010109	螺樁 Stud -----	1
10	4TC0010110	下刀 Lower Knife -----	1
11	4TC0020111	支架 Holder Bracket -----	1
12	4TC0020112	電磁鐵 Solenoid -----	1
13	8MA06400510A	螺帽 Nut (CT0533 M6-1*5) -----	2
14	8MM05321609A	螺絲 Screw (RP10111 M5-0.8*16) -----	5
15	4TC0010115	上刀 Upper Knife -----	1
16	8ME05321010A	螺絲 Screw (FTC10116 M5-0.8*10) -----	2
17	4TC0010117	護指擋片 Safety Plate Holder -----	1
18	8MB04280507K	螺絲 Screw (FT0235 M4-0.7*5) -----	2
19	4TC0010119	軸 Shaft -----	1
20	4TC0020120	曲柄 Ball Lever -----	1
21	8MN04280400A	螺絲 Screw (CT0229 M4-0.7*4) -----	1
22	8MN04280600C	螺絲 Screw (CT1104 M4-0.7*6) -----	1
23	4TC0020123	檔片 Chain-Off-Guide -----	1
24	8MP06401211A	螺絲 Screw (UTB0302 M6-1*12) -----	2
25	4TC0020125	檔片 Chain-Off-Guide -----	1
26	8ME03200606A	螺絲 Screw (CT0235 M3-0.5*6) -----	2
27	4TC0020127	連結銷 Pin -----	1
28	4TC0020128	彈簧 Spring -----	1
29	4TC0020129	滑塊 Slide Block -----	1
30	4TC0020130	曲柄 Ball Lever -----	1
31	90ER050	E形扣環 E Ring -----	1
32	4TC0020132	螺絲 Screw -----	1
33	8MB04280608A	螺絲 Screw (UTB0130 M4-0.7*6) -----	2
34	4TC0020134	減震墊 Rubber Cushion -----	1
35	4TC0020135	螺樁 Stud -----	1
36	4TC0020136	減震墊 Rubber Cushion -----	1
37	4TC0020137	螺樁 Stud -----	1
38	2100000223	墊圈 Washer(W3) -----	1
39	2200001115	墊圈 Washer -----	1
40	4TC0020140	外蓋 Cover -----	1
41	66480-11	銘板 Name Plate -----	1

TC002:FT7003 機型用 For Ft7003

TC005:FT7039 / FT7069 機型用 For Ft7003 / Ft7069

TCS02 : FT7003 / FTD7003 機型並配合伺服馬達使用 <型號HVP-60,HVP-70,HVP-90>

Must be used together with AC servo motor, HVP-60 or HVP-70 or HVP-90, for FT7003 / FTD7003 two models.

TCS05 : FT7039 / FT7069 機型並配合伺服馬達使用 <型號HVP-60,HVP-70,HVP-90>

Must be used together with AC servo motor, HVP-60 or HVP-70 or HVP-90, for Ft7039 / FT7069 two models.