

CXM SERIES

寶獅牌工業用縫紉機 INDUSTRIAL SEWING MACHINE

MODEL

CXM2500

&

UTB09

UTC09

UTG09

UTH09

STB03

STC03

WPC02

WPG01



**MECHATRONICS TYPE INDENT
SHAPE CYLINDER BED
INTERLOCK MACHINE**

Parts List



1. CXM2500 本體與外裝零件 Frame Components (一)

Subclass / Remark	Date
	2026/01/26

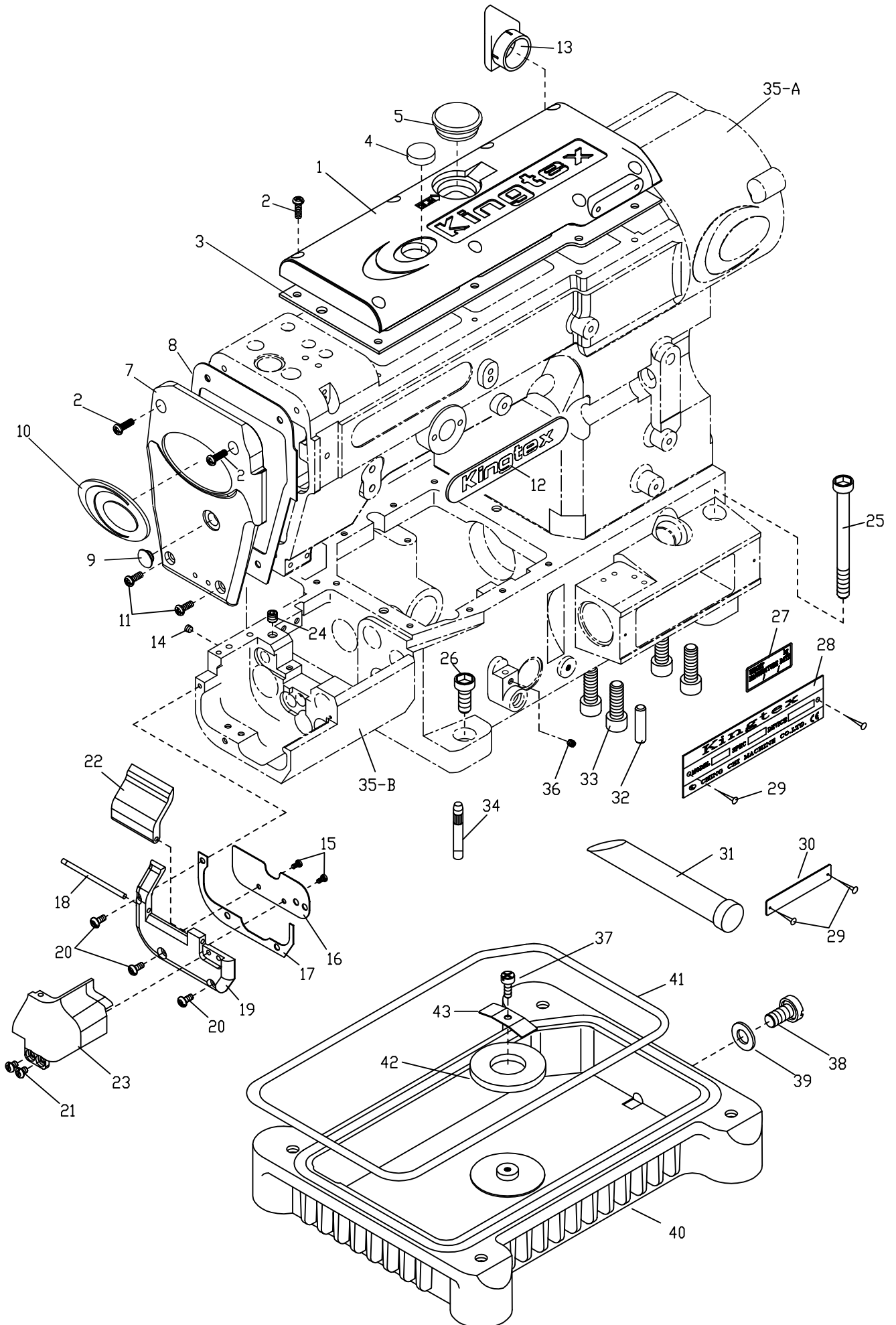

1. CXM2500 本體與外裝零件 Frame Components (一)

Subclass / Remark	Date
	2026/01/26

序號 Ref.No.	物料編號 Parts No.	名稱 Description	單位用量 Amt .Req.
1	22400001011	上軸蓋 Top Cover -----	1
2	8MC04281207D	螺絲 Screw (CT0102 M4-0.7*12) -----	10
3	22400001032	油封 Gasket -----	1
4	22400001041	油鏡 Oil Window -----	1
5	22200002552	孔塞 Plug -----	1
6	-----	-----	-
7	22400001071	針棒蓋 Needle Cover -----	1
8	22400001081	油封 Gasket -----	1
9	22000001091	孔塞 Plug -----	1
10	66484-11	銘板 Plate -----	1
11	8MC04281007D	螺絲 Screw (CT0113 M4-0.7*10) -----	2
12	66485-9	上車頭銘板 Plate -----	1
13	22400001131	導風管 Guid Pipe-----	1
14	2200001243	孔塞 Plug -----	1
15	8MB03200405A	螺絲 Screw (FT0548 M3-0.5*4) -----	2
16	2650000116	擋片 Defender -----	1
17	2650000117	油封 Gasket -----	1
18	2260000114	軸 Shaft -----	1
19	2650000119	固定座 Bucket -----	1
20	8MB85240807K	螺絲 Serew (F5-55 M3.5-0.6*8) -----	3
21	8MB04280507K	螺絲 Screw (F02-35 M4-0.7*5) -----	2
22	2650000122	側蓋 Side Cover -----	1
23	26500001231	側蓋 Side Cover -----	1
24	8MN06400600A	螺絲 Screw (CT0244 M6-1*6) -----	1
25	8MM08508513B	螺絲 Screw (CT960122 M8-1.25*30) -----	1
26	8MM08502013A	螺絲 Screw (CT0106 M8-1.25*20) -----	3
27	66477-4	重量貼紙 Weight Paster -----	1
28	66488-3	車型銘板 Model Plate -----	1
29	66620	鉚釘 Rivet -----	4
30	66480-14	機器號碼牌 Machine No. Plate -----	1
31	26000001311	油面鏡 Oil Sign Gauge-----	1
32	2200000139	定位銷 Knock Pin -----	2
33	8MM10603016A	螺絲 Serew (CT0138 M10-1.5*30) -----	4
34	2200000110	下座腳樁 Supporting Bar -----	4
35	2650000135	車頭 Frame Unit -----	1
35-A	2240000135A	車頭上座 Frame Unit -----	1
35-B	2650000135B	車頭下座 Frame Unit -----	1
36	8MN04280400A	螺絲 Screw (CT0229 M4-0.7*4) -----	1
37	8MC04280807D	螺絲 Screw (CT0130 M4-0.7*8) -----	1
38	8SM95281017A	螺樁 Stud (SH0243 3/8"-28*10) -----	1
39	2100000244	油封 Seal -----	1
40	2600000140	油盤 Oil Reservoir -----	1
41	2600000141	油封 Gasket -----	1
42	2200000128	磁鐵 Magnet -----	1
43	2200000129	壓板 Holder -----	1

2. CXM2500 本體與外裝零件 Frame Components (二)

Subclass / Remark	Date
	2026/01/26

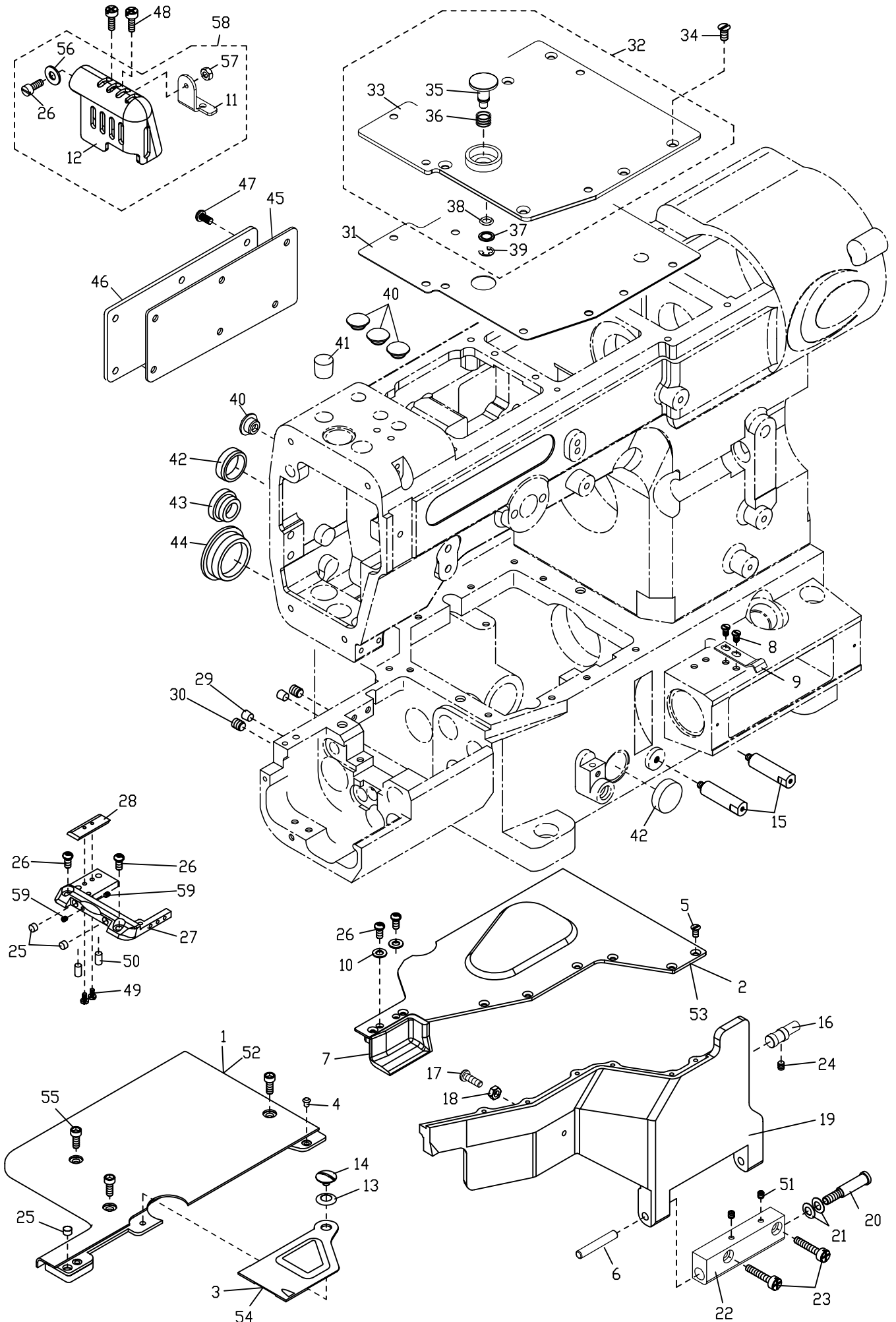

2. CXM2500 本體與外裝零件 Frame Components (二)

Subclass / Remark	Date
	2026/01/26

序號 Ref.No.	物料編號 Parts No.	名稱 Description	單位用量 Amt .Req.
*1	2604110201	下軸外蓋 Cloth Plate -----	1
*2	2650000202	護線蓋 Cloth Plate -----	1
*3	26041102031	防塵蓋 Dust Cover -----	1
4	22100001191	減震橡膠 Rubber Cushion -----	2
5	8ME03200606A	螺絲 Screw (CT0235 M3-0.5*6) -----	8
6	2310000812	軸 Shaft -----	1
7	26500002071	護蓋 Protective Cover -----	1
8	8MB04280507K	螺絲 Screw (F02-35 M4-0.7*5) -----	2
9	2600000209	夾簧 Latch Spring -----	1
10	2100000223	墊圈 Washer -----	2
11	2270000211	基座 Base -----	1
12	22700002121	針棒護蓋 Needle Bar Protector -----	1
13	2200000124	孟形墊片 Disc Washer -----	1
14	8MC04280512B	螺絲 Screw (C90232 M4-0.7*5) -----	1
15	2600000215	支撐桿 Support ing Rod -----	2
16	2600000216	限位軸 Stopper Shaft -----	1
17	8MB04281507B	螺絲 Screw (S3-31 M4-0.7*15) -----	1
18	8MA04280307A	螺帽 Nut (CT0238 M4-0.7*3) -----	1
19	2650000219	下座前蓋 Front Cover -----	1
20	8MB04283809E	螺樁 Stud (CT0227 M4-0.7*38) -----	1
21	2200000228	孟形墊圈 Disk Washer -----	2
22	2600000222	絞鏈 Hinge -----	1
23	8MC04281407D	螺絲 Screw (CT0225 M4-0.7*14) -----	2
24	8MN04280400A	螺絲 Screw (CT0229 M4-0.7*4) -----	1
25	2270000202	磁鐵 Magnet -----	3
26	8MB04280807K	螺絲 Screw (CT0215 M4-0.7*8) -----	5
27	26500002271	針板座 Needle Plate Seat -----	1
28	2650000228	活動塊 Movable Block -----	1
29	22000002471	孔塞 Plug -----	2
30	8MN06400600A	螺絲 Screw (CT0244 M6-1*6) -----	2
31	26000002312	防油墊片 Gasket -----	1
32	260A0000232	下軸內蓋組 Lower Shaft Cover Asm. -----	1
33	26000002332	下軸內蓋 Lower Shaft Cover -----	1
34	8ME04280708A	螺絲 Screw (CT0206 M4-0.7*7) -----	7
35	2600000235	止動按鈕 Push Botton -----	1
36	26000002361	彈簧 Spring -----	1
37	2130000357	墊圈 Washer (CT1025)-----	1
38	2130000362	O形油環 O Ring -----	1
39	90ER060	E形扣環 E-Ring -----	1
40	22000001091	孔塞 Plug -----	4
41	22000002081	孔塞 Plug -----	1
42	22000002451	孔塞 Plug -----	2
43	2600000243	孔塞 Plug -----	1
44	22000002461	孔塞 Plug -----	1
45	22000002091	油封 Gasket -----	1
46	2200000210	上軸背蓋 Rear Cover -----	1
47	8MC04281007D	螺絲 Screw (CT0113 M4-0.7*10) -----	6
48	8MC04280807D	螺絲 Screw (CT0130 M4-0.7*8)-----	2
49	8MB75180505A	螺絲 Screw (CTS0218 M2.5-0.45*5) -----	2
50	90ST0407	定位銷 Knock Pin -----	2
51	8MN04280600A	螺絲 Screw (CT1223 M4-0.7*6) -----	2
**52	2600850101	下軸外蓋 Cloth Plate -----	1
**53	2650000253	護線蓋 Cloth Plate -----	1
**54	26041102541	防塵蓋 Dust Cover -----	1
55	8MM04281207A	螺絲 Screw (CT0202 M4-0.7*12) -----	3
56	90DW040	墊圈 Washer -----	1
57	8MA04280207A	螺帽 Nut (STC02-01-02 M4-0.7*2.5) -----	1
58	227A0000259	針棒護蓋組 Needle Bar Protector Asm. -----	1
59	8MN03200400A	螺絲 Screw (UH01-25 M3-0.5*4) -----	2

* : 40M,48M,56M用 For 40M, 48M,56M

** : 64M用 For 64M

CXM2500-S2 系列通用 2604110201 / 2650000202 / 26041102031

3. CXM2000 / CXM2500 導線與張力調整零件 Thread Guide And Tension Components

Subclass / Remark	Date
	2025/11/27

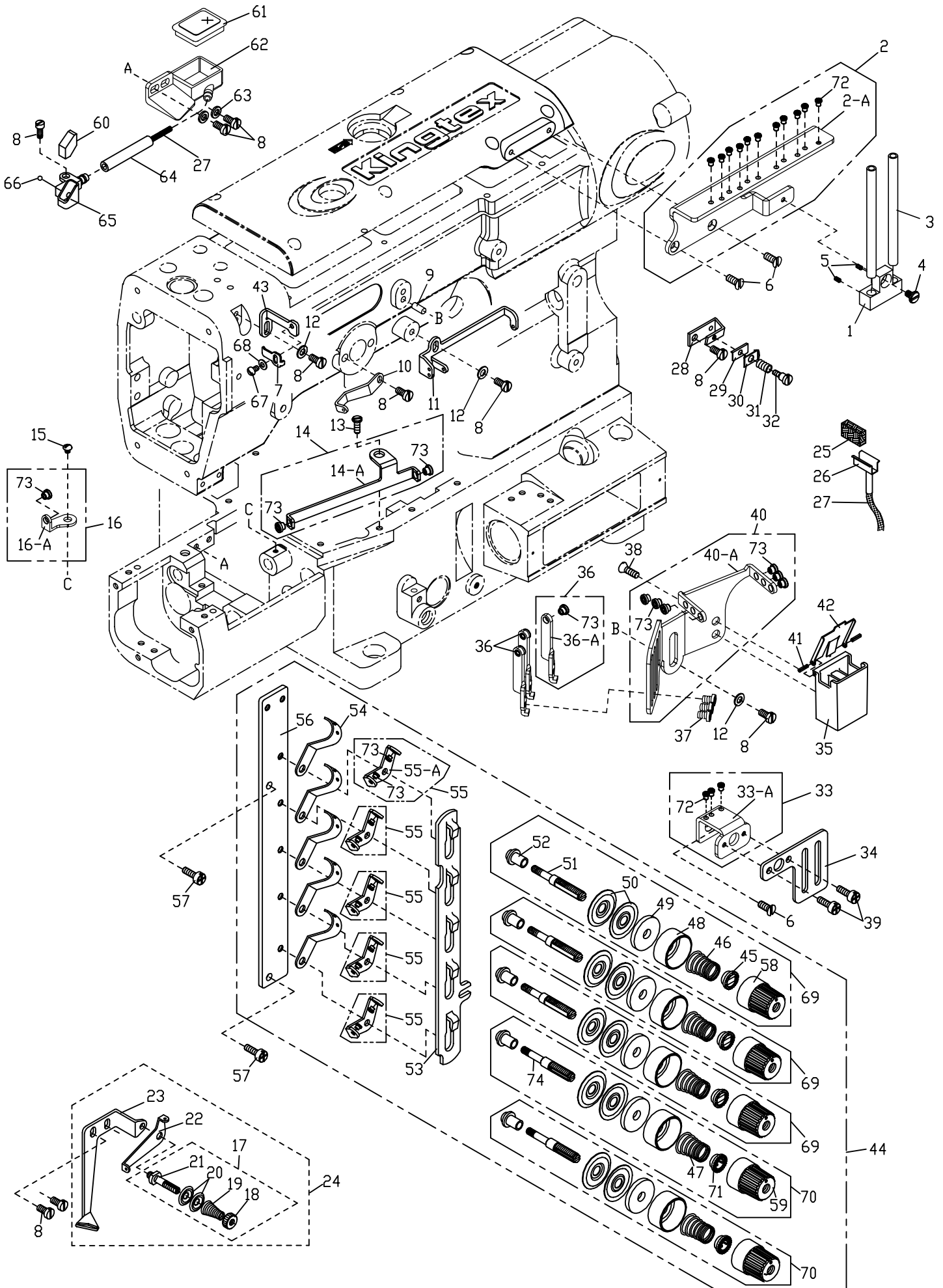

3. CXM2000 / CXM2500 導線與張力調整零件 Thread Guide And Tension Components

Subclass / Remark	Date
	2025/11/27

序號 Ref.No.	物料編號 Parts No.	名稱 Description	單位 Amt.	用量 Req.
1	2240000301	導線座 Thread Guide Holder	1	1
2	2600000302	導線座組 Thread Guide Holder Asm.	1	1
2-A	2600000302A	導線座 Thread Guide Holder	1	1
3	2200000327	導線管 Thread Guide Pipe	2	2
4	8MB04280608A	螺絲 Screw (UTB0130 M4-0.7*6)	1	1
5	8MN03200300A	螺絲 Screw (CT0115 M3-0.5*3)	2	2
6	8ME04280708A	螺絲 Screw (CT0206 M4-0.7*7)	3	3
7	2600000307	導線 Thread Guide	1	1
8	8MB04280807K	螺絲 Screw (CT0215 M4-0.7*8)	10	10
9	90ST0410	定位銷 Knock Pin	1	1
10	2210000317	導線 Thread Guide	1	1
11	2210000326	導線 Thread Guide	1	1
12	2100000223	墊圈 Washer	3	3
13	8MB04281107A	螺絲 Screw (CXD0313 M4-0.7*11)	1	1
14	26000003142	導線組 Thread Guide Asm.	1	1
14-A	26000003142A	導線 Thread Guide	1	1
15	8MD03200306A	螺絲 Screw (CT0242 M3-0.5*3)	1	1
16	26000003161	導線組 Thread Guide Asm.	1	1
16-A	26000003161A	導線 Thread Guide	1	1
17	227A0000342	張力控制組 Thread Retainer Asm.	1	1
18	2200000357	螺帽 Nut	1	1
19	2200000356	彈簧 Spring	1	1
20	2200000355	張力控制盤 Tension Disc	2	2
21	2200000354	螺樁 Stud	1	1
22	2200000353	導線 Thread Guide	1	1
23	2200000352	導線 Thread Guide	1	1
24	220A0000365	鬆線組 Therad Tension Mechanism	1	1
25	2200000339	羊毛氈 Felt	1	1
26	2200000338	線夾 Wick Clamp	1	1
27	66800	油線 Oil Wick	2	2
28	2200000347	張力控制組座 Thread Retainer Support	1	1
29	2200000348	針線控制板 Thread Guide Plate	1	1
30	2200000349	針線控制壓板 Tension Control plate	1	1
31	22000003501	彈簧 Spring	1	1
32	8MC03200907G	螺樁 Stud (CT90351 M3-0.5*9)	1	1
33	2600000333	導線組 Thread Guide Asm.	1	1
33-A	2600000333A	導線 Thread Guide	1	1
34	2200000359	揚線臂護線罩 Take-up Arm Protect	1	1
35	2600000335	油杯 Cooler Oil Tank	1	1
36	2600000336	導線桿組 Thread Guide Asm.	3	3
36-A	2600000336A	導線桿 Thread Guide	3	3
37	8MB03200405A	螺絲 Screw (FT0548 M3-0.5*4)	3	3
38	8TE03440806A	螺絲 Screw	2	2
39	8MC04280507D	螺絲 Screw (CT0122 M4-0.7*5)	2	2
40	2600000340	導線組 Thread Guide Asm.	1	1
40-A	2600000340A	導線 Thread Guide	1	1
41	90SP0206T	彈簧銷 Spring Pin	2	2
42	2200000336	油杯蓋 Cooler Oil Tank Cover	1	1
43	2600000343	導線 Thread Guide	1	1
44	260A00003441	鬆線組 Therad Tension Mechanism	1	1
45	2200000303	套管 Bushing	3	3
46	2100001123	彈簧 Spring (Red) (SH1123)	3	3
47	2100041131	彈簧 Spring (Yellow) (SH1131)	2	2
48	2200000305	彈簧座 Spring Seat	5	5
49	2100001127	羊毛氈 Felt	5	5
50	2100001126	張力控制盤 Tension Disc	10	10
51	22000003081	螺樁 Stud	3	3
52	22000003091	隔環 Spacer	5	5
53	4UTB0004191	鬆線滑板 Release Wedge	1	1
54	2200000312	導線 Thread Guide	5	5
55	2600000355	導線組 Thread Guide Asm.	5	5
55-A	2600000355A	導線 Thread Guide	5	5
56	4UTB000420	張力控制組座 Tension Post Support	1	1
57	8MC04280807D	螺絲 Screw (CT0130 M4-0.7*8)	2	2
58	2100001121	張力調整螺帽 Tension Nut (Red) (SH1121)	3	3
59	2100001121A	張力調整螺帽 Tension Nut (Yellow) (SH1121)	2	2
60	2200000732	羊毛氈 Felt	1	1
61	26000003611	冷卻油槽蓋 Cooler Oil Tank Cover	1	1
62	26000003622	冷卻油槽 Cooler Oil Tank	1	1
63	240003013	墊圈 Washer	2	2
64	66792	油管 Oil Tube (Ø4.6 * Ø6.3 * 52 L)	1	1
65	22000007311	羊毛氈承座 Felt Seat	1	1
66	2100000403	孔塞 Plug	1	1
67	8MB03200506K	螺絲 Screw (CT0525 M3-0.5*5)	1	1
68	90DW030	碟形墊圈 Disk Washer	1	1
69	231A0001922	張力控制組 Thread Asm. (Red)	3	3
70	220A0000315	張力控制組 Thread Asm. (Yellow)	2	2
71	2100001122	止滑齒輪 Bush	2	2
72	240013088	磁導線環 Thread Eyelet	14	14
73	240013087	磁導線環 Thread Eyelet	22	22
74	22000003611	螺樁 Stud	2	2

4. CXM2000 / CXM2500 軸襯與油封 Bushing And Seal

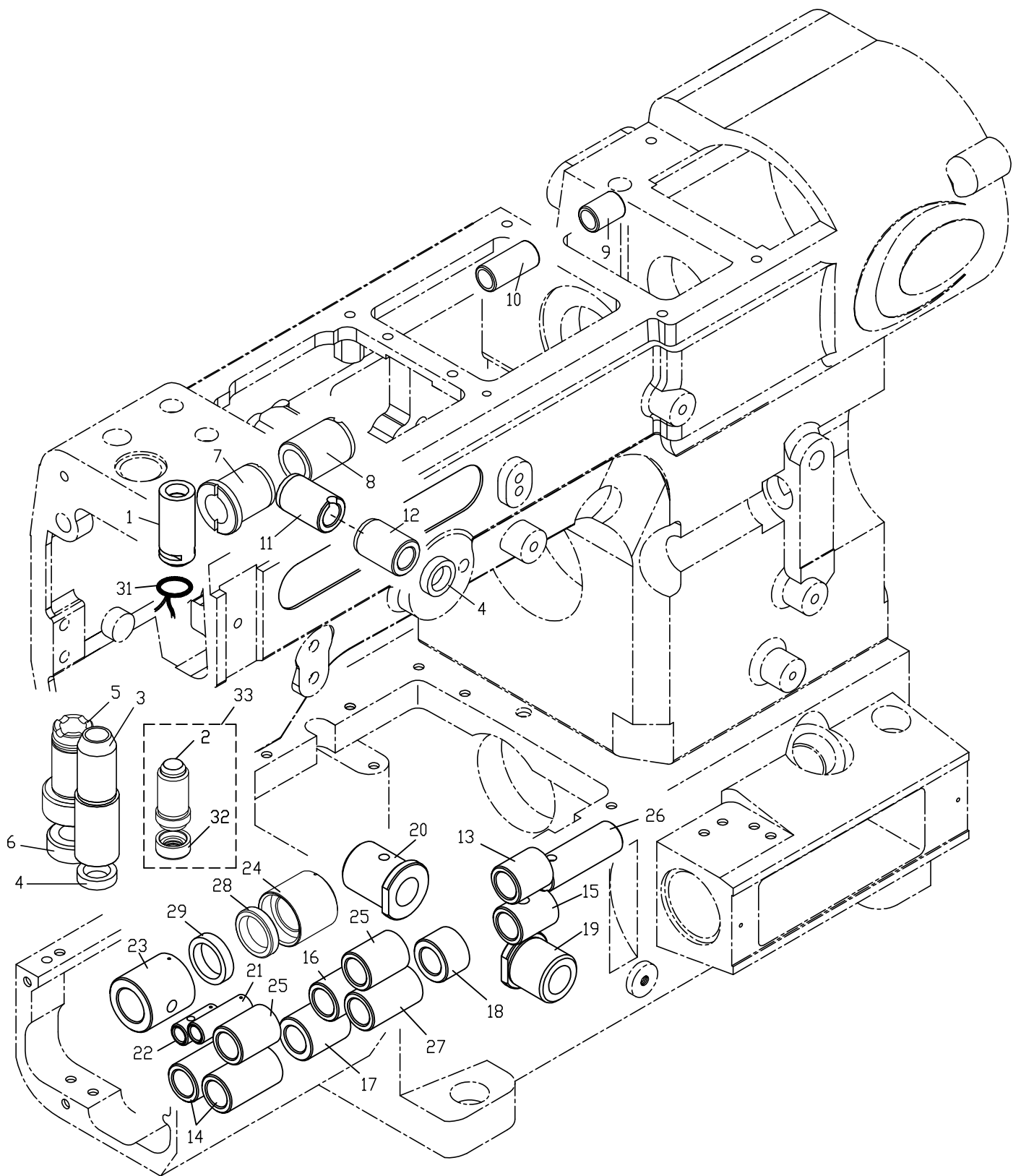

4. CXM2000 / CXM2500 軸襯與油封 Bushing And Seal

序號 Ref.No.	物料編號 Parts No.	名稱 Description	單位用量 Amt .Req.
1	2210000401	軸襯 Bushing -----	1
2	22000004021	軸襯 Bushing -----	1
3	2200000403	軸襯 Bushing -----	1
4	2200000404	油封 Oil Seal -----	2
5	22200004051	軸襯 Bushing -----	1
6	2200000406	油封 Oil Seal -----	1
7	2210000408	軸襯 Bushing -----	1
8	2200000408	軸襯 Bushing -----	1
9	2240000409	軸襯 Bushing -----	1
10	2240000422	軸襯 Bushing -----	1
11	2200000411	軸襯 Bushing -----	1
12	22000004101	軸襯 Bushing -----	1
13	2600000413	軸襯 Bushing -----	1
14	2600000414	軸襯 Bushing -----	2
15	2600000415	軸襯 Bushing -----	1
16	2600000416	軸襯 Bushing -----	1
17	26000004171	軸襯 Bushing -----	1
18	2600000418	軸襯 Bushing -----	1
19	26000004191	軸襯 Bushing -----	1
20	26000004201	軸襯 Bushing -----	1
21	26000004211	軸襯 Bushing -----	1
22	26000004221	軸襯 Bushing -----	1
23	26000004231	軸襯 Bushing -----	1
24	26000004241	軸襯 Bushing -----	1
25	2600000425	軸襯 Bushing -----	2
26	2600000426	軸襯 Bushing -----	1
27	26000004271	軸襯 Bushing -----	1
28	2600000428	油封 Oil Seal -----	1
29	2600000429	羊毛氈 Felt -----	1
30	-----	-----	-
31	66800	油線 Oil Wick -----	1
32	2270001017	橡膠環 Rubber Washer -----	1
33	227A0000423	軸襯組 Bushing Asm. -----	1

5. CXM2000 / CXU2000 / CXM2500 / CXU2500 / CXM4000 / CXU4000
 下軸與相關零件 Lower Main Shaft Components

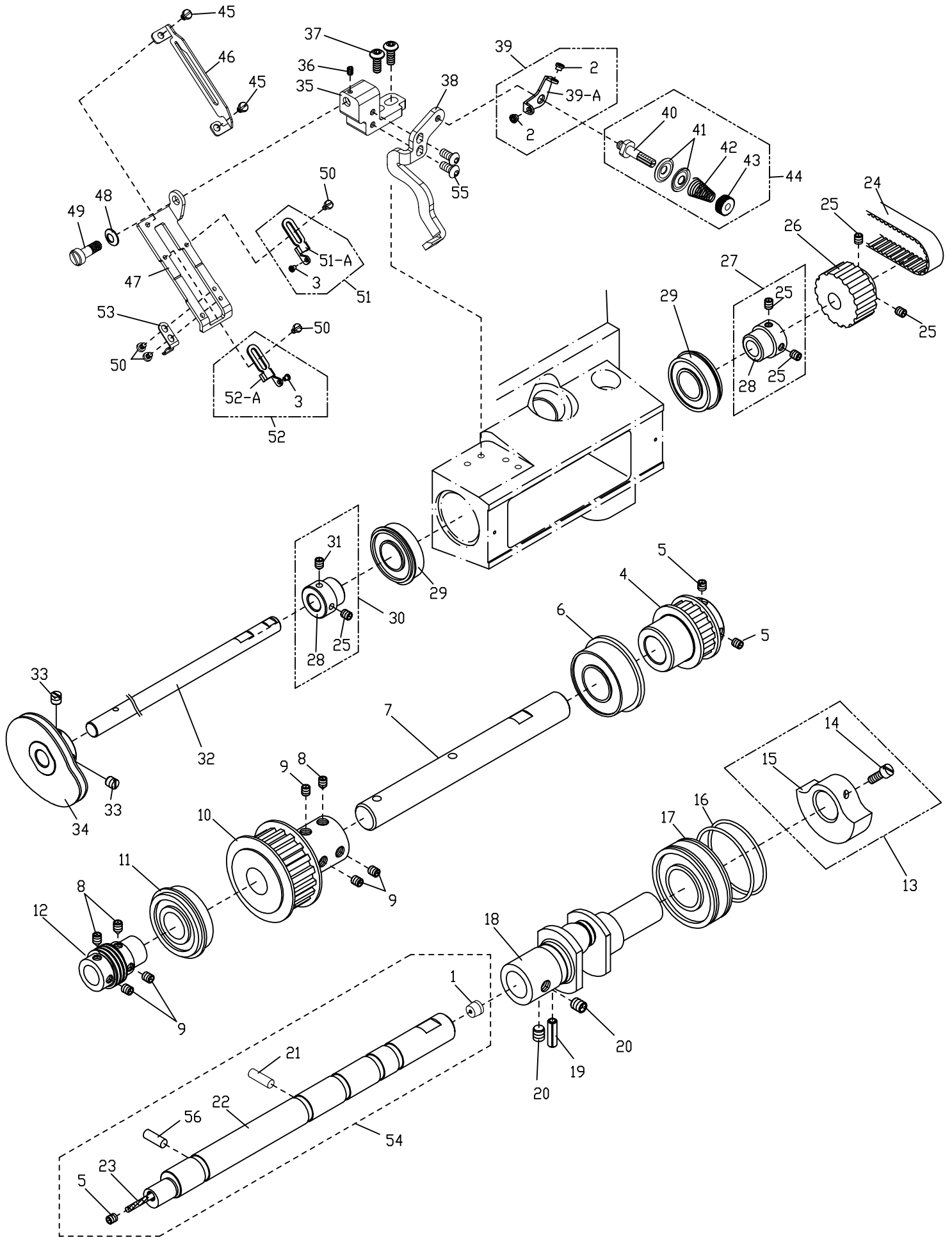

5. CXM2000 / CXU2000 / CXM2500 / CXU2500 / CXM4000 / CXU4000

下軸與相關零件 Lower Main Shaft Components

序號 Ref.No.	物料編號 Parts No.	名稱 Description	單位用量 Amt .Req.
1	2200000515	孔塞 Plug -----	1
2	240013087	磁導線環 Thread Eyelet -----	2
3	2600000371	磁導線環 Thread Eyelet -----	2
4	2220000504	齒形皮帶輪 Timeing Pulley -----	1
5	8MN05320500E	螺絲 Screw (CT0903 M5-0.8*5) -----	3
6	90BB2552154	滾珠軸承 Ball Bearing -----	1
7	2246110501	軸 Shaft -----	1
8	8MN06400800C	螺絲 Screw (FT0502 M6-1*8) -----	3
9	8MN06400600A	螺絲 Screw (CT0244 M6-1*6) -----	5
10	2240000505	齒形皮帶輪 Timeing Pulley -----	1
11	90BB2047144	滾珠軸承 Ball Bearing -----	1
12	2200000508	蝸桿 Worm -----	1
13	222A0000647	平衡錘組 Balance Weight Asm -----	1
14	8MB04280807K	螺絲 Screw (CT0215 M4-0.7*8) -----	2
15	2200000509	平衡錘 Balance Weight -----	1
16	2200000547	O形油環 O Ring -----	2
17	90BB2042122	滾珠軸承 Ball Bearing -----	1
18	2200000512	曲軸 Crank Shaft -----	1
19	90SP0206	彈簧銷 Pin -----	1
20	8MN06400500A	螺絲 Screw (CT0513 M6-1*5) -----	2
21	90SP0206T	彈簧銷 Pin -----	1
22	2600000522	軸 Shaft -----	1
23	240010041	油線 Oil Wick (L=100mm) -----	1
24	90TB2883GT	齒形皮帶 Timeing Belt -----	1
25	8MN04280400A	螺絲 Screw (CT0229 M4-0.7*4) -----	5
26	2220000540	齒形皮帶輪 Timeing Pulley -----	1
27	227A0000552	套管接頭組 Joint Asm -----	1
28	2270000545	套管接頭 Joint -----	2
29	90BB152807	滾珠軸承 Ball Bearing -----	2
30	226A0000552	套管接頭組 Joint Asm -----	1
31	8MN04280500C	螺絲 Screw (FT1222 M4-0.7*5) -----	1
32	2600000532	軸 Shaft -----	1
33	8MH05320400A	螺絲 Screw (CT0523 M5-0.8*4) -----	2
34	2270000522	揚線凸輪 Looper Thread Takeup Cam -----	1
35	2600000535	固定座 Bracket -----	1
36	8MN03200400A	螺絲 Screw (UH01-25 M3-0.5*4) -----	1
37	8MP04281008A	螺絲 Screw (MT0250 M4-0.7*10) -----	2
38	2600000538	支架 Knife Holder Bracket -----	1
39	26000005391	導線組 Thread Guide Asm. -----	1
39-A	26000005391A	導線 Thread Guide -----	1
40	2260000322	螺樁 Stud -----	1
41	2200000355	張力控制盤 Tension Disc -----	2
42	2200000356	彈簧 Spring -----	1
43	2200000357	螺帽 Nut -----	1
44	226A0000323	張力控制組 Thread Retainer Asm -----	1
45	8MB03200306A	螺絲 Screw (FT0208 M3-0.5*3) -----	2
46	26000005461	導線 Thread Guide -----	1
47	26000005472	導線固定板 Thread Guide Seat -----	1
48	2200000228	碟形墊圈 Disk Washer -----	1
49	8MB05321409B	螺絲 Screw (CXD05-49 M5-0.8*14) -----	1
50	8MB75180405A	螺絲 Screw (C05-29 M2.5-0.45*3.5) -----	4
51	26000005511	導線組 Thread Guide Asm. -----	1
51-A	26000005511A	導線 Thread Guide -----	1
52	26000005521	導線組 Thread Guide Asm. -----	1
52-A	26000005521A	導線 Thread Guide -----	1
53	2600000553	夾簧 Latch Spring -----	1
54	260A0000560	下軸組 Lower Shaft Set. -----	1
55	8MP04280808A	螺絲 Screw (MT0235 M4-0.7*8) -----	2
56	66803	φ 2.2纖維棒 Oil Wick -----	1

6. CXM2000 / CXM2500

上軸與相關零件 Upper Main Shaft Components

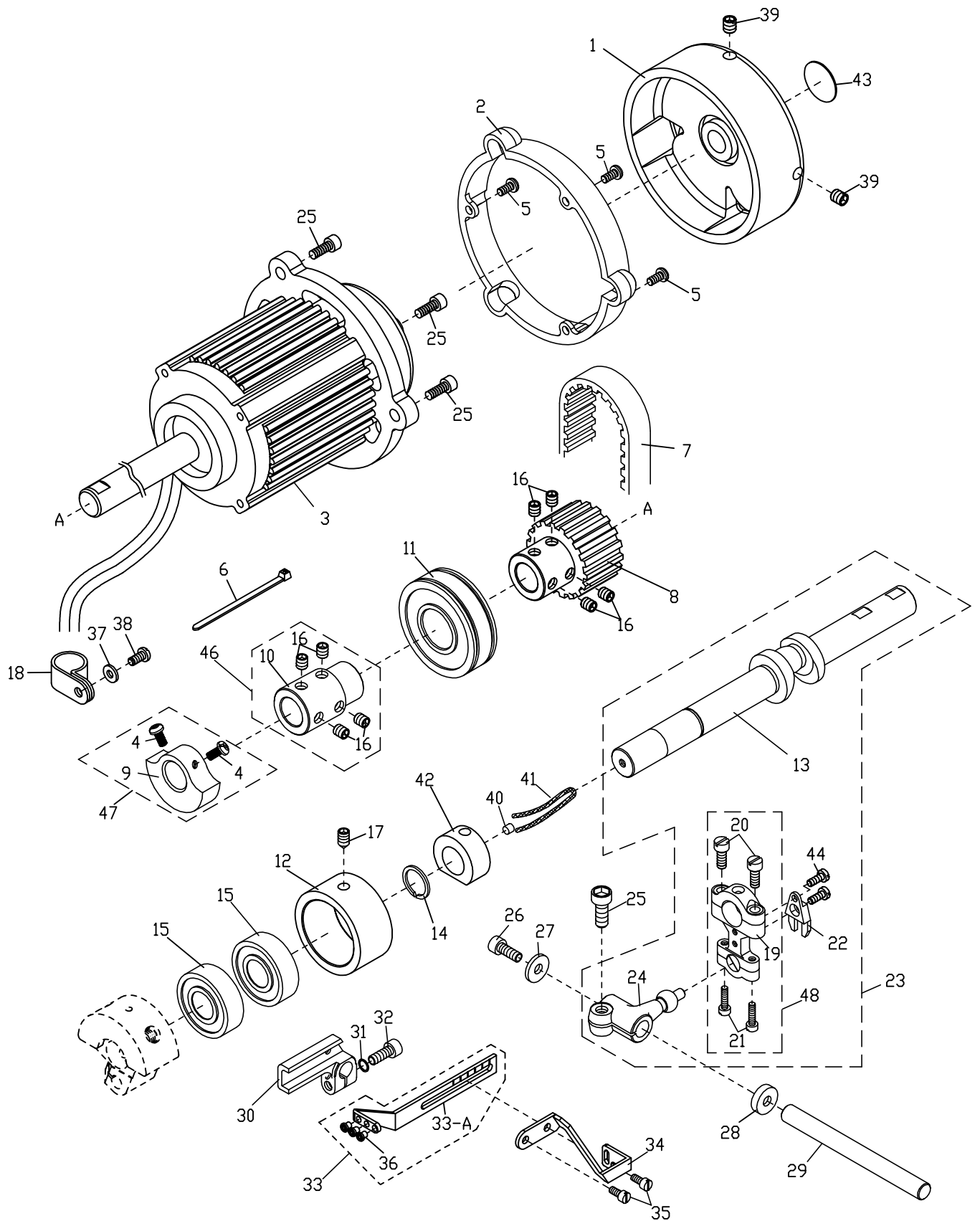

6. CXM2000 / CXM2500 上軸與相關零件 Upper Main Shaft Components

序號 Ref.No.	物料編號 Parts No.	名稱 Description	單位用量 Amt .Req.
1	2600000601	賀欣手輪 Handwheel -----	1
2	2240000602	護蓋 Cover -----	1
3	2600000661	賀欣迷你馬達 Mini Motor -----	1
4	8MB04280807K	螺絲 Screw(CT0215 M4-0.7*8) -----	2
5	8MP04280808A	螺絲 Screw (MT0235 M4-0.7*8) -----	3
6	4UTB020306	束線Plastic Binding Wire-----	1
7	2200000607	齒形皮帶 Timeing Belt -----	1
8	22400006081	齒形皮帶輪 Timeing Pulley -----	1
9	2200000509	平衡錘 Balance Weight -----	1
10	2200000610	套管接頭 Joint -----	1
11	90BB204714	滾珠軸承 Ball Bearing -----	1
12	2240000612	軸承套筒 Bearing Sleeve -----	1
13	2210000613	曲軸 Crank Shaft -----	1
14	90SCR150	C形軸用扣環 C Ring -----	1
15	90BB1535115	滾珠軸承 Ball Bearing -----	2
16	8MN06400600A	螺絲 Screw(CT0244 M6-1*6) -----	8
17	8MN06400800C	螺絲 Screw(FT05-02 M6-1*8) -----	1
18	4MN0210108	線夾 Cord Clamp -----	1
19	2200000619	連桿 Connecting Rod -----	1
20	8MB95301407K	螺絲 Screw(CT0620 M4.5-0.75*14) -----	2
21	8MB85241006K	螺絲 Screw(CT0621 M3.5-0.6*10) -----	2
22	2200000622	定向導軌 Orient Guide -----	1
23	221A0000653	曲軸組 Crank Shaft Asm -----	1
24	2200000624	曲柄 Ball Lever -----	1
25	8MM06401610A	螺絲 Screw (CT0625 M6-1*16) -----	4
26	8MM05321009A	螺絲 Screw (CT0626 M5-08*10) -----	1
27	2200000627	墊圈 Washer -----	1
28	2200000628	隔環 Spacer -----	1
29	2200000629	軸 Shaft -----	1
30	2200000630	承座 Bracket -----	1
31	90SW050	彈簧墊圈 Spring Washer -----	1
32	8MM05321409A	螺絲 Screw (CT0632 M5-0.8*14) -----	1
33	2600000633	導線組 Thread Guide Asm. -----	1
33-A	2600000633A	導線 Thread Guide -----	1
34	2220000634	裝飾線揚線桿 Thread Take-up -----	1
35	8MB85240807K	螺絲 Screw (FT0555 M3.5-0.6*8) -----	2
36	240013088	磁導線環 Thread Eyelet -----	3
37	2100000223	墊圈 Washer -----	1
38	8MB04280807K	螺絲 Screw (C02-15 M4-0.7*8) -----	1
39	8MN06400800A	螺絲 Screw (CT0549 M6-1*8) -----	2
40	2100001404	孔塞 Plug (S14-04)-----	1
41	66800	油線 Oil Wick -----	1
42	2240000642	聚油環 Oil Sleeve -----	1
43	66485-10	銘板 Plate -----	1
44	8MB03200806A	螺絲 Screw (CT900623 M3-0.5*8) -----	2
45	-----	-----	-
46	222A0000646	套管接頭組 Joint Asm -----	1
47	222A0000647	平衡錘組 Balance Weight Asm -----	1
48	222A0000648	連桿組 Connecting Rod Asm -----	1

7. CT9000 / CTD9000 / CXM2000 / CXM2500 針棒與相關零件 Needle Bar Components

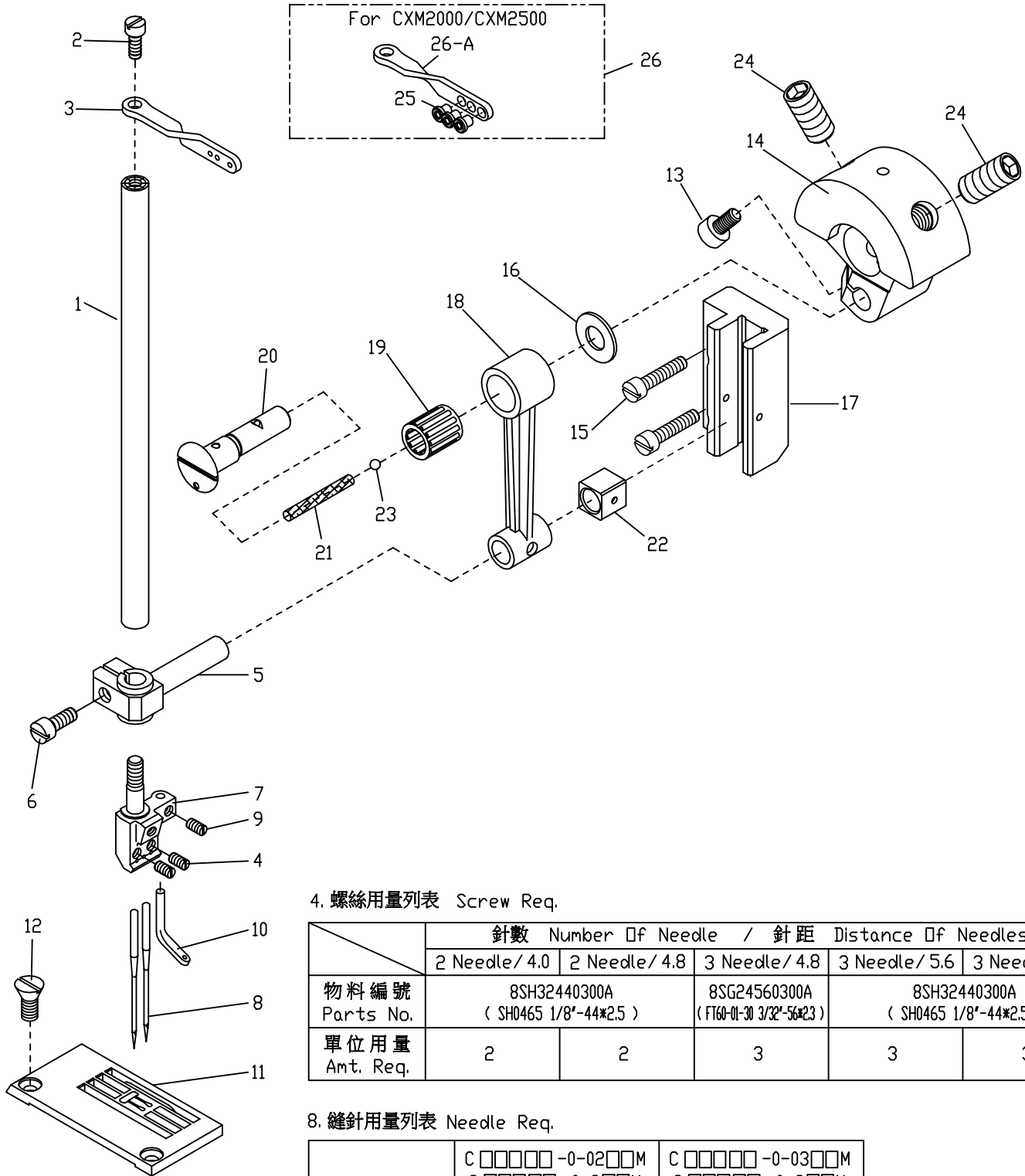

4. 螺絲用量列表 Screw Req.

	針數 Number of Needle / 針距 Distance of Needles				
	2 Needle / 4.0	2 Needle / 4.8	3 Needle / 4.8	3 Needle / 5.6	3 Needle / 6.4
物料編號 Parts No.	8SH32440300A (SH0465 1/8"-44*2.5)		8SG24560300A (FT60-01-30 3/32"-56*2.3)	8SH32440300A (SH0465 1/8"-44*2.5)	
單位用量 Amt. Req.	2	2	3	3	3

8. 縫針用量列表 Needle Req.

針號 UY128GAS 66725-11-5	C □ □ □ □ -0-02 □ □ M	C □ □ □ □ -0-03 □ □ M
	C □ □ □ □ -0-2 □ □ M	C □ □ □ □ -0-3 □ □ M
	C □ D □ □ □ -0-02 □ □ M	C □ D □ □ □ -0-03 □ □ M
	C □ D □ □ □ -0-2 □ □ M	C □ D □ □ □ -0-3 □ □ M
針數 Needle	2	3

序號 Ref.No.	名稱 Description	針數 Number of Needle / 針距 Distance of Needles				
		2 Needle / 4.0	2 Needle / 4.8	3 Needle / 4.8	3 Needle / 5.6	3 Needle / 6.4
7	針留 Needle Clamp	5220NC00400	5220NC00480	5220NC00485	5227NC00560	5227NC00640
11	針板 Needle Plate	5222TP00401	5220TP00484	5220TP00484	5220TP00564	5220TP00642

7. CT9000 / CTD9000 / CXM2000 / CXM2500

針棒與相關零件 Needle Bar Components

序號 Ref.No.	物料編號 Parts No.	名稱 Description	單位用量 Amt. Req.
1	22000007011	針棒 Needle Bar -----	1
2	8MB85240607K	螺絲 Screw (CT0637 M3.5-0.6*6) -----	1
3	2200000703	導線 Thread Guide -----	1
4	-----	螺絲 Screw (See Left Page) -----	-
5	2210000705	針棒驅動銷 Needle Bar Clamp -----	1
6	8MB95301107K	螺絲 Screw (CT0706 M4.5-0.75*11) -----	1
7	-----	針留 Needle clamp (See Left Page) -----	1
8	-----	針 Needle --(UY128GAS See Left Page)-----	-
9	8SH32440300A	螺絲 Screw (SH0465 1/8"-44*2.5) -----	1
10	2200000710	導線 Thread Guide -----	1
11	-----	針板 Needle Plate (See Left Page) -----	1
12	8SF36400706C	螺絲 Screw (CT0712 9/64"-40*7.5) -----	2
13	8MM05321009A	螺絲 Screw (C06-26 M5-0.8*10) -----	1
14	2270000714	平衡錘 Balance Weight -----	1
15	8MB04281607A	螺絲 Screw (CT0724 M4-0.7*16) -----	2
16	2270000716	墊圈 Washer -----	1
17	2210000727	滑道 GuideBlock -----	1
18	2210000720	連桿 Connecting Rod -----	1
19	90NB081113	滾針軸承 Needle Bearing -----	1
20	2270000720	曲柄銷 Rod Pin -----	1
21	66800	油線 Oil Wick -----	1
22	2200000722	滑塊 Slide Block -----	1
23	2100001404	孔塞 Plug -----	1
24	8MN08401600E	螺絲 Screw (CT0618 M8-1*16) -----	2
△25	240013088	磁導線環 Thread Eyelet -----	3
△26	2600000703	導線組 Thread Guide Asm. -----	1
△26-A	2600000703A	導線 Thread Guide -----	1

△ CXM2000 / CXM2500 專用

8. CTD9000 / CTD9711 / CTM9711 / CXM2000 / CXM2500 / CXM2711 / CXM4000 壓腳與相關零件 Presser Foot Components

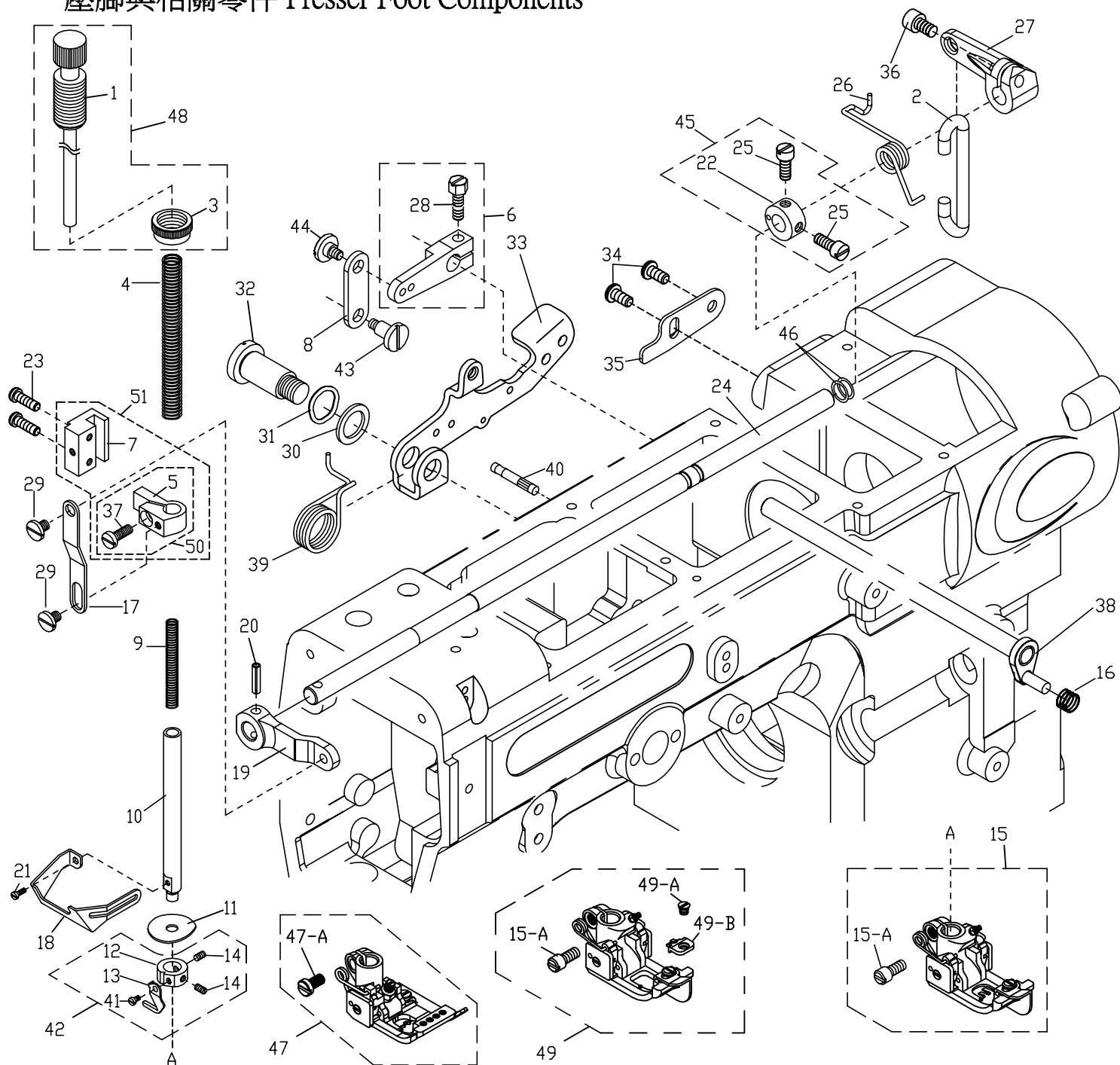

CTD9000 / CXM2000 / CXM2500 / CXM4000 機型用

序號 Ref.No.	名稱 Description	針數 Number Of Needle / 針距 Distance Of Needles				
		2 Needle/4.0	2 Needle/4.8	3 Needle/4.8	3 Needle/5.6	3 Needle/6.4
15	壓腳 Presser foot asm	5220PF00404	5220PF00484	5220PF00485	5220PF00564	5220PF00644

CTD9711 / CTM9711 / CXM2711 機型用

序號 Ref.No.	名稱 Description	針數 Number Of Needle / 針距 Distance Of Needles			
		2 Needle/4.0	3 Needle/4.8	3 Needle/5.6	3 Needle/6.4
47	壓腳 Presser foot asm	5222PF11400	5222PF11480	5222PF11560	5222PF11640

特註品 (CTD9000 / CXM2000 / CXM2500 / CXM4000) 機型用

序號 Ref.No.	名稱 Description	針數 Number Of Needle / 針距 Distance Of Needles				
		2 Needle/4.0	2 Needle/4.8	3 Needle/4.8	3 Needle/5.6	3 Needle/6.4
49	壓腳 Presser foot asm	5224PF00400	5224PF00480	5224PF00481	5224PF00560	5224PF00640
49-B	壓腳舌 Presser foot tongue	5224PF0040A	5224PF0048A	5224PF00481A	5224PF0056A	5224PF0064A

8. CTD9000 / CTD9711 / CTM9711 / CXM2000 / CXM2500 / CXM2711 / CXM4000

壓腳與相關零件 Presser Foot Components

序號 Ref.No.	物料編號 Parts No.	名稱 Description	單位用量 Amt. Req.
1	2220000801	壓力調整螺椿 Spring Regulator -----	1
2	2240000802	吊桿 Lifter Connecting Plate -----	1
3	2220000803	螺帽 Nut -----	1
4	2200000804	彈簧 Spring -----	1
5	2200000805	壓腳棒連結臂 Presser Bar Clamp -----	1
*6	2240000806	曲柄 Drive Arm -----	1
7	2200000807	滑道 Guide Block -----	1
*8	2240000808	連桿 Link -----	1
9	2200000809	彈簧 Spring -----	1
10	2200000810	壓腳棒 Presser Bar -----	1
11	2200000811	阻油片 Oil Separator -----	1
12	2220000812	限動環 Stop Collar -----	1
13	2220000813	固定切刀 Knife -----	1
14	8MH85240300A	螺絲 Screw (CT0813 M3.5-0.6*3) -----	2
15	-----	CTD9000壓腳 Presser Foot(See Left Page) -----	1
15-A	5220PF0356M	螺絲 Screw (M3.5-0.6*8) -----	1
*16	4UTB000411	彈簧 Spring -----	1
17	2200000817	連桿 Link -----	1
18	2220000818	護指擋片 Safety Plate Holder -----	1
19	2240000819	連桿 Lever -----	1
20	90SP0416	彈簧銷 Spring Pin -----	1
21	8MB85240607K	螺絲 Screw (CT0637 M3.5-0.6*6) -----	1
22	2200000822	定位環 Collar -----	1
23	8MB95301407K	螺絲 Screw (CT0620 M4.5-0.75*14) -----	2
24	22400008241	軸 Shaft -----	1
25	8MC95300606F	螺絲 Screw (CT0823 M4.5-0.75*5.5) -----	2
26	2240000826	彈簧 Spring -----	1
27	2240000827	連桿 Link -----	1
28	8MK95301407A	螺絲 Screw (CT0837 M4.5-0.75*14) -----	1
29	8MB05320509G	螺椿 Stud (CT0802 M5-0.8*5) -----	2
30	2310001012	墊圈 Washer -----	1
31	2310001207	波形墊圈 Corrugated Ring -----	1
32	2310001013	螺椿 Stud -----	1
33	22400008331	揚昇臂 Lifter Arm -----	1
*34	8MP06401011A	螺絲 Screw (MT0234 M6-1*10) -----	2
*35	2240000835	限位片 Stopper -----	1
36	8MM06401210A	螺絲 Screw (F1103 M6-1*12) -----	1
37	8MC95300808E	螺絲 Screw (CT0806 M4.5-0.75*8) -----	1
*38	2240000838	軸 Shift -----	1
39	2240000839	彈簧 Spring -----	1
40	2310001017	銷 Pin -----	1
41	8MB03200405A	螺絲 Screw (FT0548 M3-0.5*4) -----	1
42	222A0000842	限動環組 Stop Collar Asm -----	1
*43	2310000343	螺椿 Stud -----	1
*44	2310000344	螺椿 Stud -----	1
45	220A0000825	定位環組 Collar Asm.-----	1
46	2240000846	O形油環 O Ring -----	2
47	-----	CTD9711壓腳 Presser Foot(See Left Page) -----	1
47-A	8MB85240605A	螺絲 Screw (CT1002 M3.5-0.6*6)-----	1
48	222A0000843	壓力調整螺椿組 Spring Regulator Set -----	1
◎49	-----	壓腳 Presser Foot -----	1
◎49-A	5221PF6056C	螺絲 Screw -----	1
◎49-B	-----	壓腳舌 Press Foot Tongue -----	1
50	220A0000843	壓腳棒連結臂組 Presser Bar Clamp Set -----	1
51	220A0000844	滑道組 Guide Block Set -----	1

* 為標準型專用，切線 (UT 系列) 時不使用

* For basic model only. Not applicable to thread trimmer (UT series) series.

◎ 特註品 Custom-made Item

9. CT9000 / CT9711 / CTD9000 / CTD9711 / CTM9711 / CXM2000 / CXM2711
 CXM2500 / CXM4000 裝飾線驅動機構 Spreader Mechanism

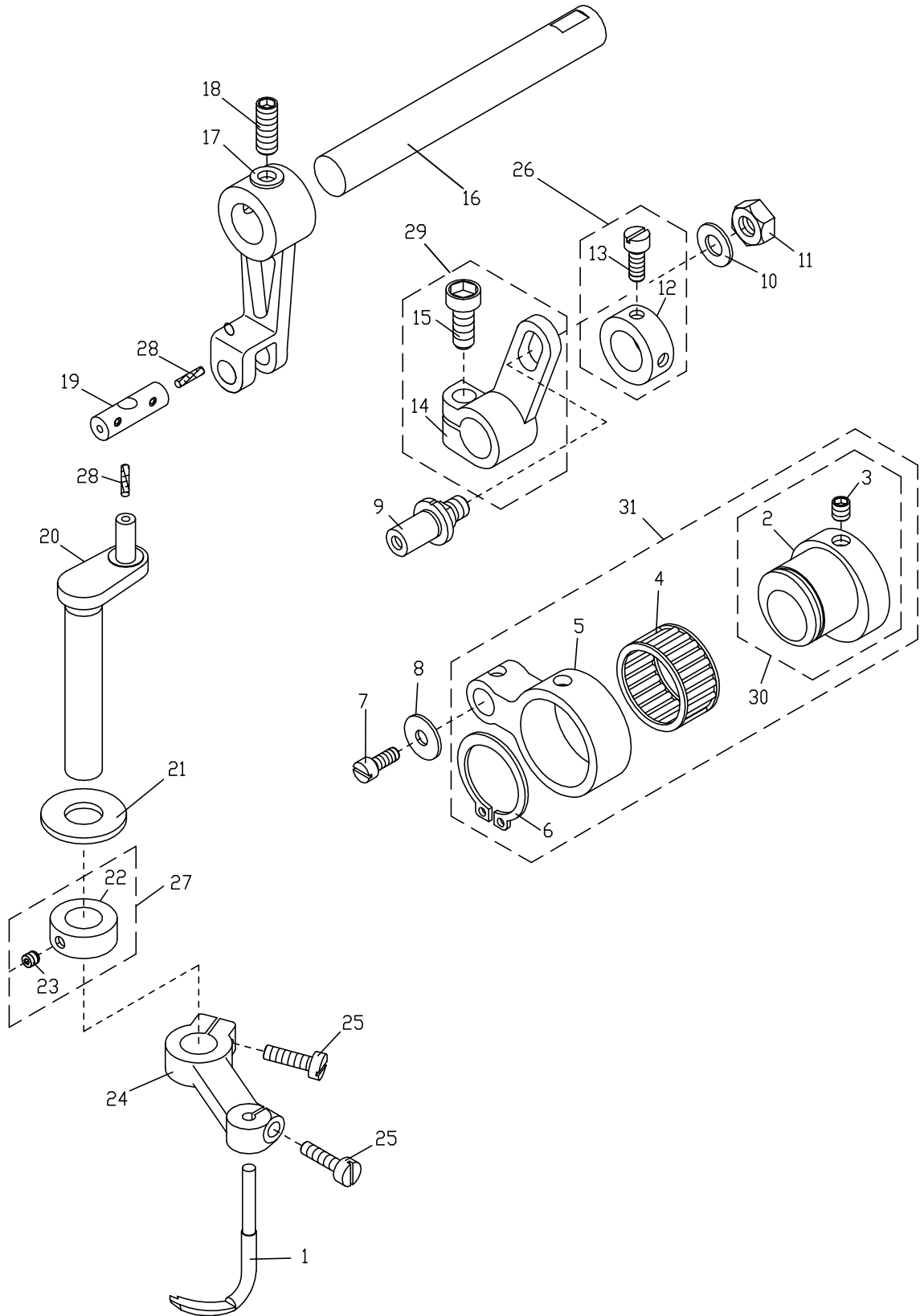

9. CT9000 / CT9711 / CTD9000 / CTD9711 / CTM9711 / CXM2000 / CXM2711

CXM2500 / CXM4000 裝飾線驅動機構 Spreader Mechanism

序號 Ref.No.	物料編號 Parts No.	名稱 Description	單位用量 Amt. Req.
1	5220SL00560	裝飾線結線鉤 Spreader -----	1
2	2200000902	偏心輪 Eccentric -----	1
3	8MN05320500E	螺絲 Screw (CT0903 M5-0.8*5) -----	2
4	90NB222613	滾針軸承 Needle Bearing -----	1
5	2200000905	連桿 Connecting Rod -----	1
6	90SCR220	軸用C形扣環 C Ring -----	1
7	8MB04280807K	螺絲 Screw (CT0215 M4-0.7*8) -----	1
8	2200000908	墊圈 Washer -----	1
9	2200000909	曲柄銷 Rod Pin -----	1
10	2200000910	墊圈 Washer -----	1
11	8MA06400510A	螺帽 Nut (CT0533 M6-1*5) -----	1
12	2200000912	定位環 Collar -----	1
13	8MC95300606F	螺絲 Screw (CT0823 M4.5-0.75*5.5) -----	2
14	2200000914	變距曲柄 Lever -----	1
15	8MM06401610A	螺絲 Screw (CT0625 M6-1*16) -----	1
16	2200000916	軸 Shaft -----	1
17	2220000917	連桿 Connecting Rod -----	1
18	8MN06400600A	螺絲 Screw (CT0244 M6-1*6) -----	2
19	2220000919	連桿銷 Rod Pin -----	1
20	2220000920	曲軸 Crank Shaft -----	1
21	2200000921	墊圈 Washer -----	1
22	2200000922	定位環 Collar -----	1
23	8MN85240300A	螺絲 Screw (UH0302 M3.5-0.6*3) -----	2
24	22000009241	擺動臂 Spreader Arm -----	1
25	8MB04281207K	螺絲 Screw (CT0239 M4-0.7*12) -----	2
26	220A0000926	定位環組 Collar Asm -----	1
27	220A0000927	定位環組 Collar Asm -----	1
28	66801	油線 Oil Wick -----	2
29	222A0000929	變距曲柄 Lever -----	1
30	222A0000930	偏心輪組 Collar Asm -----	1
31	222A0000931	偏心輪組 Collar Asm -----	1

10. CXM2000 / CXM2500 / CXM4000 / CXU2000 / CXU2500 / CXU4000
 結線鉤驅動機構 Looper Driving Mechanism

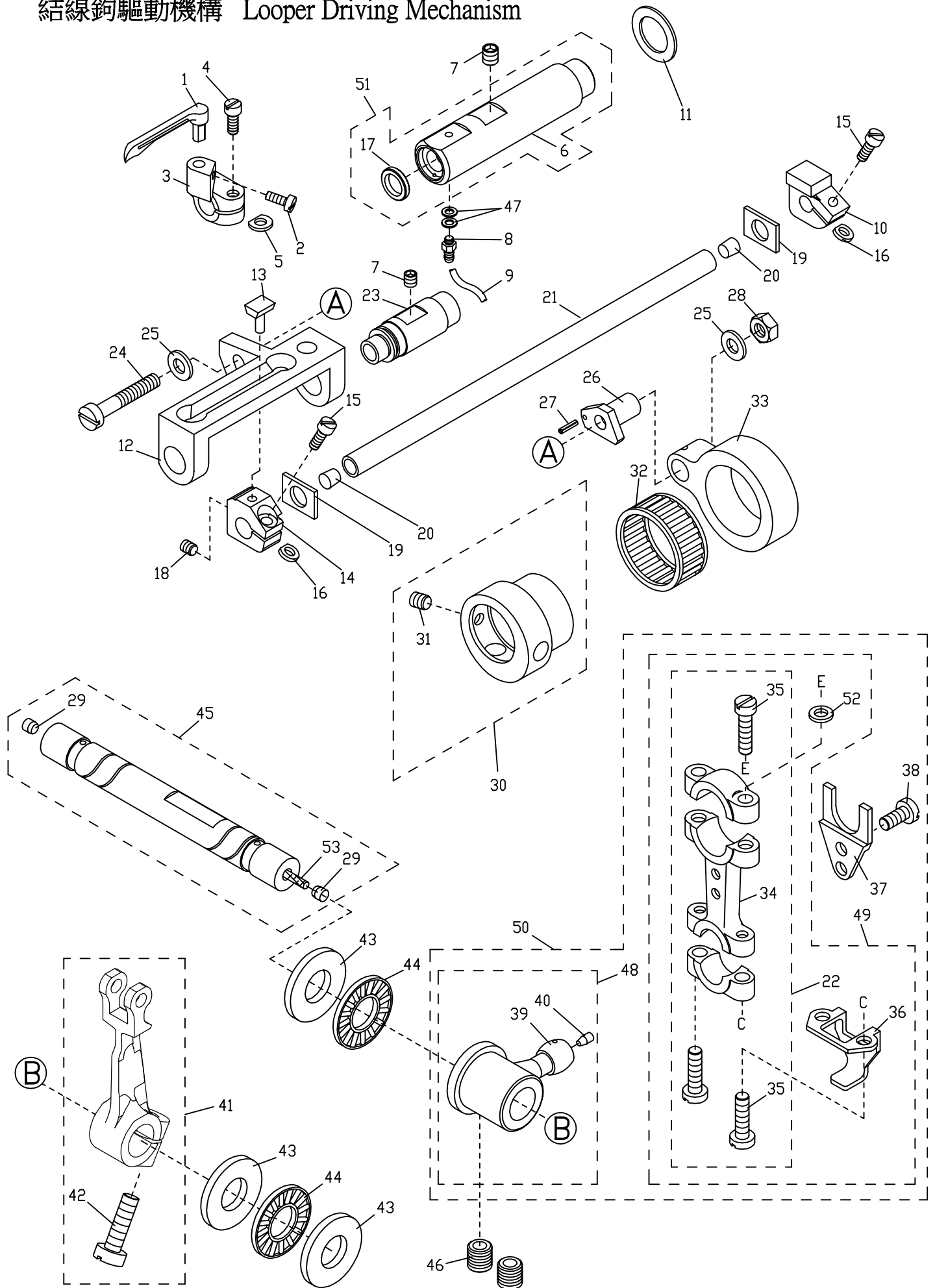

10. CXM2000 / CXM2500 / CXM4000 / CXU2000 / CXU2500 / CXU4000

結線鉤驅動機構 Looper Driving Mechanism

序號 Ref.No.	物料編號 Parts No.	名稱 Description	單位用量 Amt. Req.
1	5220LL00560	下結線鉤 Looper -----	1
2	8MB85240605A	螺絲 Screw (CT1002 M3.5--0.6*6) -----	1
3	2200001003	結線鉤座 Looper Holder -----	1
4	8MB85241006K	螺絲 Screw (CT0621 M3.5-0.6*10) -----	1
5	2200001005	墊圈 Washer -----	1
6	26000010062	軸襯 Bushing -----	1
7	8MN06400600A	螺絲 Screw (CT0244 M6-1*6) -----	2
8	2100001505	油嘴 Oil Tube Joint (SH1505) -----	1
9	66790	油管 Oil Tube (Ø2.9 * Ø5 * 35 L)-----	1
10	2220001010	滑塊固定座 Slider Holder -----	1
11	2200001011	墊圈 Washer -----	1
12	22200010121	滑道 Guide Block -----	1
13	2200001013	滑塊 Slide block -----	1
14	2600001014	滑塊固定座 Slider Holder -----	1
15	8MB85241106A	螺絲 Screw (CT1015 M3.5-0.6*11) -----	2
16	2200001016	墊圈 Washer -----	2
17	22700010171	油封 Oil Seal -----	1
18	8MN04280400A	螺絲 Screw (CT0229 M4-0.7*4) -----	1
19	2200001019	止推墊片 Thrust Plate -----	2
20	22000002471	孔塞 Plug -----	2
21	2220001021	結線鉤驅動軸 Looper Drive Bar -----	1
22	220A0001022	連桿組 Connecting Rod Asm -----	1
23	22200010231	軸襯 Bushing -----	1
24	8MB05323009B	螺絲 Screw (CT1024 M5-0.8*30) -----	1
25	2200001025	墊圈 Washer -----	2
26	2200001026	變距連桿銷 Adjusting Pin -----	1
27	2200001027	彈簧銷 Spring Pin -----	1
28	8MA05320408A	螺帽 Nut (CT1028 M5-0.8*4) -----	1
29	2200001029	孔塞 Plug -----	2
30	2200001030	偏心輪 Eccentric -----	1
31	8MN05320500E	螺絲 Screw (CT0903 M5-0.8*5) -----	1
32	90NB263013	滾針軸承 Needle Bearing -----	1
33	2200001033	連桿 Rod -----	1
34	2200001034	連桿 Connecting Rod -----	1
35	8MB95301407K	螺絲 Screw (CT0620 M4.5-0.75*14) -----	4
36	2200001036	潑油片 Oil Splasher -----	1
37	2200001037	定向導片 Orient Guide -----	1
38	8MB95301008A	螺絲 Screw (SS033-01-16 M4.5-0.75*10) -----	2
39	22000010391	曲柄 Lever -----	1
40	2100000328	孔塞 Plug -----	1
41	2600001041	擺動臂 Rocker Arm -----	1
42	8MM06401610A	螺絲 Screw (CT0625 M6-1*16) -----	1
43	2200001043	止推墊圈 Thrust Washer -----	3
44	2200001044	止推軸承 Thrust Bearing -----	2
45	2200001045	軸 Shaft -----	1
46	8MN08500800A	螺絲 Screw (CT10461 M8-1.25*8) -----	2
47	2200001047	墊圈 Washer -----	2
48	220A0001048	曲柄組 Lever Asm -----	1
49	220A0001049	連桿組 Connecting Rod Asm -----	1
50	220A0001050	連桿組 Connecting Rod Asm -----	1
51	260A00010511	軸襯組 Bushing Asm. -----	1
52	2100000640	墊圈 Washer -----	2
53	66800	油線 Oil Wick -----	1

11. CXM2000 / CXM2500 / CXM4000 / CXU2000 / CXU2500 / CXU4000

進給變換機構 Feed Control Driving

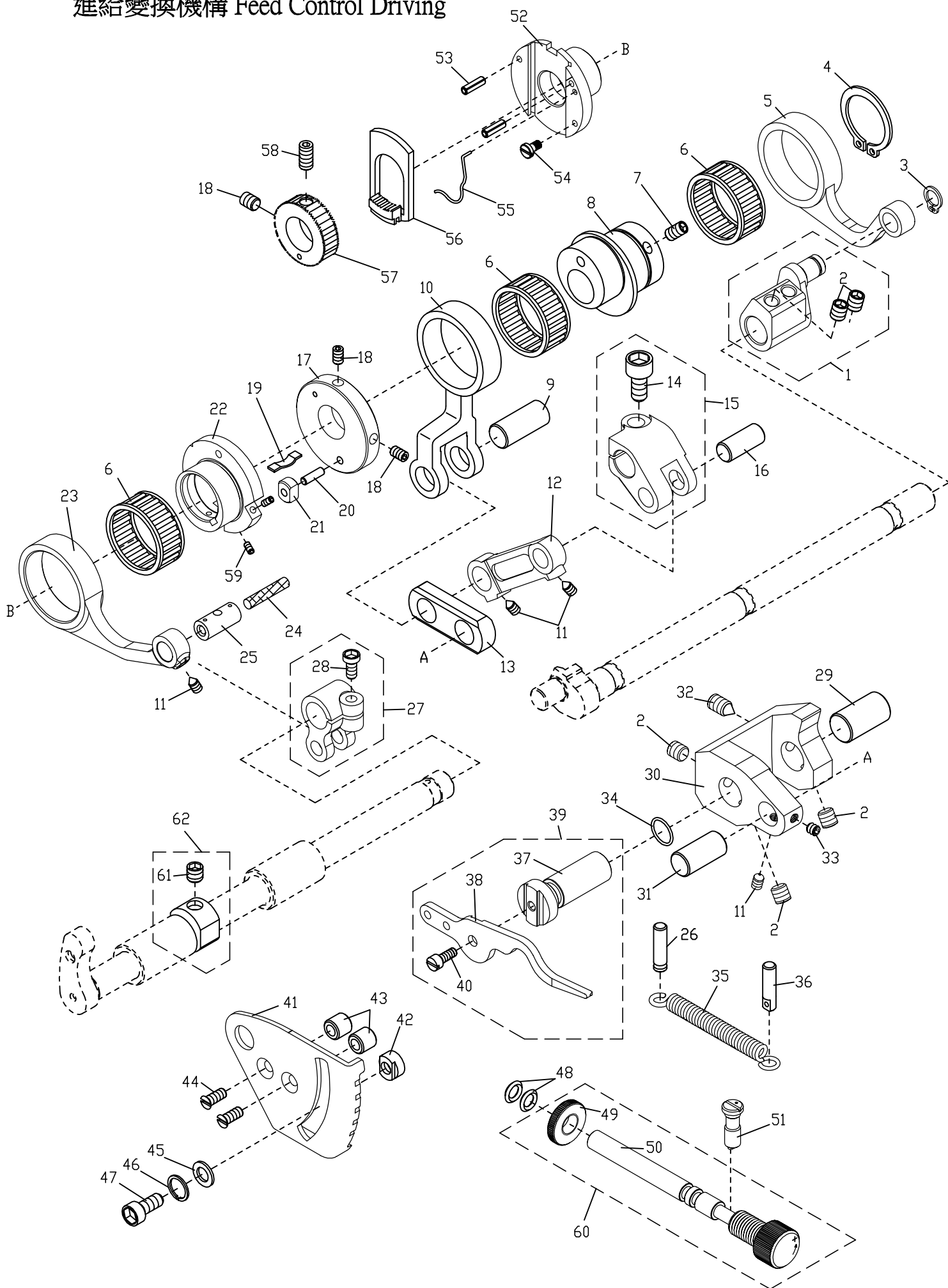

11. CXM2000 / CXM2500 / CXM4000 / CXU2000 / CXU2500 / CXU4000

進給變換機構 Feed Control Driving

序號 Ref.No.	物料編號 Parts No.	名稱 Description	單位用量 Amt. Req.
1	2600001101	曲柄 Lever -----	1
2	8MN06400600A	螺絲 Screw (CT0244 M6-1*6) -----	5
3	90SCR070	C形軸用扣環 C Ring -----	1
4	2200001106	C形軸用扣環 C Ring -----	1
5	2600001105	連桿 Rod -----	1
6	90NB252910	滾針軸承 Needle Bearing -----	3
7	8MN05320500E	螺絲 Screw (CT0903 M5-0.8*5) -----	2
8	2600001108	偏心輪 Eccentric -----	1
9	2200001111	連桿銷 Rod Pin -----	1
10	2600001110	連桿 Rod -----	1
11	8MN04280600C	螺絲 Screw (CT1104 M4-0.7*6) -----	4
12	2600001112	連桿 Link -----	1
13	2200001113	連桿 Link -----	1
14	8MM06401210A	螺絲 Screw (F11-03 M6-1*12) -----	1
15	2600001115	曲柄 Lever -----	1
16	2600001116	連桿銷 Rod Pin -----	1
17	2600001117	變距銷座 Eccentric Collar -----	1
18	8MN05320600A	螺絲 Screw (MT0729 M5-0.8*6) -----	3
19	2120000348	簧片 Connection -----	1
20	90ST0310	定位銷 Knock Pin -----	1
21	2274111453	變距銷 Pin -----	1
22	2600001122	進給偏心輪 Eccentric -----	1
23	2600001123	連桿 Link -----	1
24	66800	油線 Oil Wick -----	1
25	2200001241	連桿銷 Pin -----	1
26	2200001122	彈簧掛鉤 Pin -----	1
27	26000011271	變距偏心輪 Eccentric -----	1
28	8MM04281207A	螺絲 Screw (CT0202 M4-0.7*12) -----	1
29	2600001129	連桿銷 Rod Pin -----	1
30	2600001130	承座 Bracket -----	1
31	2600001131	連桿銷 Rod Pin -----	1
32	8MN06400800C	螺絲 Screw (FT0502 M6-1*8) -----	1
33	8MN04280400A	螺絲 Screw (CT0229 M4-0.7*4) -----	1
34	90OR090	O形油環 O Ring -----	1
35	26000011354	彈簧 Spring -----	1
36	2600001136	彈簧掛鉤 Pin -----	1
37	2600001137	差動游標軸 Shaft -----	1
38	2600001138	差動變換桿 Lever -----	1
39	260A0001139	差動變換桿組 Lever Set -----	1
40	8MB04280807K	螺絲 Screw (CT0215 M4-0.7*8) -----	1
41	2600001141	差動刻記板 Regulator Plate -----	1
42	2200001142	止動環 Stopper -----	1
43	2600001143	隔環 Spacer -----	2
44	8ME04281408A	螺絲 Screw (C1140 M4-0.7*14) -----	2
45	2200001025	墊圈 Washer -----	1
46	90SW050	彈簧墊圈 Spring Washer -----	1
47	8MM05320809A	螺絲 Screw (CT1145 M5-0.8*8) -----	1
48	90OR0517	O形油環 O Ring -----	2
49	2600001149	螺帽 Nut -----	1
50	2600001150	螺樁 Stud -----	1
51	2600001151	止動銷 Stopper Pin -----	1
52	26000011521	變距偏心輪 Eccentric -----	1
53	90SP0310	彈簧銷 Pin -----	2
54	8MB03200606B	螺絲 Screw (MT0851 M3-0.5*3) -----	1
55	23100008211	彈簧 Spring -----	1
56	2310000809	離合齒片 Regulating Plate -----	1
57	2310000808	離合齒輪 Regulating Gear -----	1
58	8MN05321000E	螺絲 Screw (MT0843 M5-0.8*10) -----	1
59	8MN03200500A	螺絲 Screw (STB0116 M3-0.5*5) -----	2
60	260A0001160	調整螺樁組 Adjusting Screw Asm. -----	1
61	8MN06400500A	螺絲 Screw (CT0513 M6-1*5) -----	1
62	2600001213	定位環 Collar -----	1

12. CXM2500 / CXU2500

導針與送布齒驅動機構 Needle Guide And Feed Dog Driving

Subclass / Remark	Date
	2026/01/26

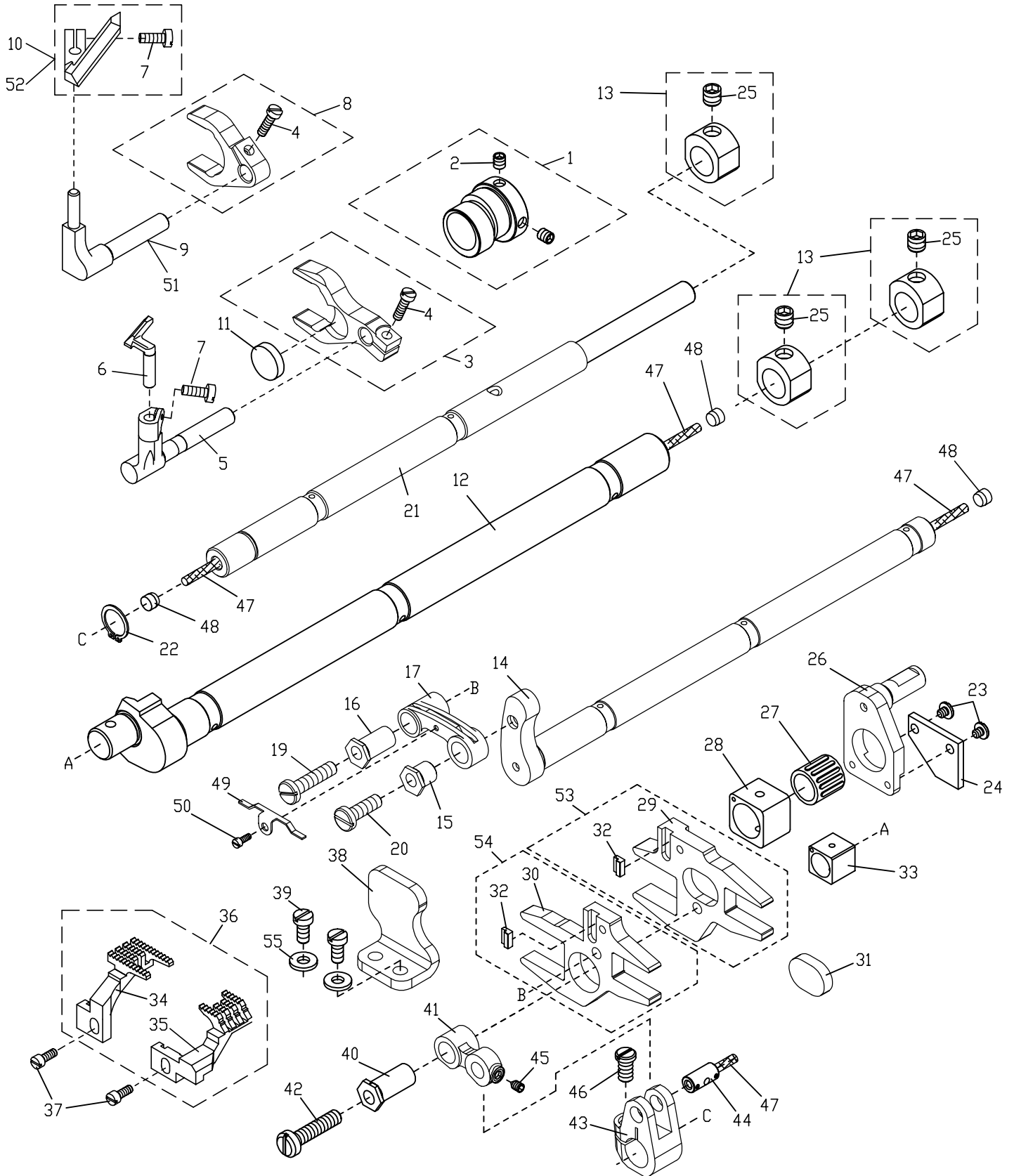

序號 Ref.No.	名稱 Description	針距 Distance Of Needles			
		4.0	4.8	5.6	6.4
34	主送布齒 Main Feed Dog	5220FD00563	5220FD00563	5220FD00563	5220FD00643
35	副送布齒 Diff Feed Dog	5265DF00560	5265DF00560	5265DF00560	5265DF00640
36	送布齒組 Feed Dog Asm.	5265DG0001	5265DG0001	5265DG0001	5265DG0002

12. CXM2500 / CXU2500

Subclass / Remark	Date
	2026/01/26

導針與送布齒驅動機構 Needle Guide And Feed Dog Driving

序號 Ref.No.	物料編號 Parts No.	名稱 Description	單位用量 Amt. Req.
1	2600001201	導針擺動凸輪 Eccentric Cam -----	1
2	8MN04280400A	螺絲 Screw (CT0229 M4-0.7*4) -----	2
3	2600001203	導針擺動曲柄 Lever -----	1
4	8MB03201006A	螺絲 Screw (CT1204 M3-0.5*10) -----	2
5	2600001205	前導針座 Needle Guide Holder -----	1
6	5220NG00563	前導針器 Needle Guide -----	1
7	8MB03200606K	螺絲 Screw (CT1207 M3-0.5*6) -----	2
8	2600001208	導針擺動曲柄 Lever -----	1
*9	2600001209	後導針座 Needle Guide Holder -----	1
10	5220NG00562	後導針器 Needle Guide -----	1
11	2600001211	羊毛氈 Felt -----	1
12	26000012121	曲軸 Crank Shaft -----	1
13	2600001213	定位環 Collar -----	3
14	26000012141	曲軸 Crank Shaft -----	1
15	26000012151	連桿銷 Pin -----	1
16	26000012161	連桿銷 Pin -----	1
17	2600001217	連桿 Link -----	1
18	-----	-----	-
19	8MB05322109A	螺絲 Screw (CXD1219 M5-0.8*21) -----	1
20	8MB05321609X	螺絲 Screw (CXD1220 M5-0.8*15.5) -----	1
21	2600001221	軸 Shaft -----	1
22	90SCR110	C形軸用扣環 C Ring -----	1
23	8MB03200306X	螺絲 Screw (UTB0436 M3-0.5*3) -----	2
24	2600001224	羊毛氈 Felt -----	1
25	8MN06400500A	螺絲 Screw (CT0513 M6-1*5) -----	3
26	2600001226	送布齒座導軌 Guide -----	1
27	90NB101313	滾針軸承 Needle Bearing -----	1
28	2600001228	滑塊 Slide Block -----	1
29	2600001229	主送布齒驅動座 Feed Dog Seat -----	1
30	2600001230	副送布齒驅動座 Feed Dog Seat -----	1
31	2600001231	羊毛氈 Felt -----	1
32	2200001232	送布齒定位鍵 Locator Key -----	2
33	2200001245	滑塊 Slide Block -----	1
34	-----	主送布齒 Main Feed Dog(See Left Page) -----	1
35	-----	副送布齒 Diff.Feed Dog(See Left Page) -----	1
36	-----	送布齒組 Feed Dog Asm. (See Left Page) -----	1
37	8MB85240806K	螺絲 Screw (CT0635 M3.5-0.6*8) -----	2
38	2600001238	送布齒座導軌 Guide -----	1
39	8MB04280807K	螺絲 Screw (CT0215 M4-0.7*8) -----	2
40	26000012401	連桿銷 Pin -----	1
41	2600001241	連桿 Link -----	1
42	8MB05322209K	螺絲 Screw (CXD1242 M5-0.8*22) -----	1
43	2600001243	曲柄 Shaft -----	1
44	2600001244	連桿銷 Pin -----	1
45	8MN03200400C	螺絲 Screw (CT1242 M3-0.5*4) -----	1
46	8MB05320907A	螺絲 Screw (CXD1246 M5-0.8*9) -----	1
47	66800	油線 Oil Wick -----	4
48	2200001243	孔塞 Plug -----	3
49	2600001249	擋片 Defender -----	1
50	8MB75180605A	螺絲 Screw (CTS0221 M2.5-0.45*6) -----	1
51	2600001251	後導針座 Needle Guide Holder -----	1
*52	5220NG00561	後導針器 Needle Guide -----	1
53	260A0001253	主送齒驅動座組 Feed Dog Seat Asm -----	1
54	260A0001254	副送齒驅動座組 Feed Dog Seat Asm -----	1
55	2100000223	墊圈 Washer -----	2

* 特註品 Custom-Item

13. CXM2000/CXM2500/CXM4000/CXD3800 潤滑系統 Lubrication System

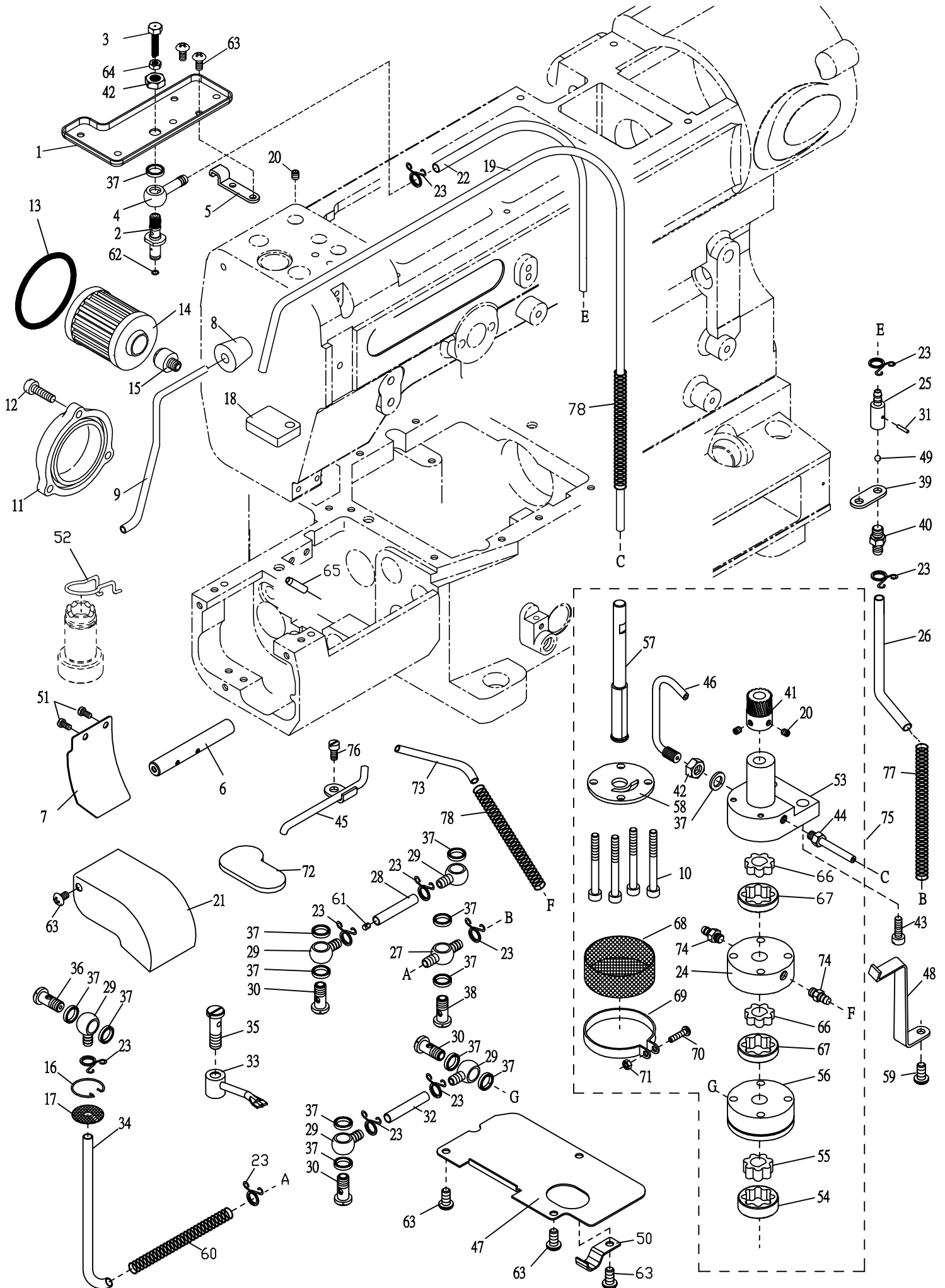

13. CXM2000 / CXM2500 / CXM4000 / CXM3800

潤滑系統 Lubrication System

序號 Ref.No.	物料編號 Parts No.	名稱 Description	單位用量 Amt. Req.
1	2240001301	承油盤 Oil Receiver -----	1
2	2240001302	油管 Oil Tube -----	1
3	2240001303	噴油嘴 Nozzle -----	1
4	2240001304	油管接頭 Oil Tube Joint -----	1
5	22400013051	擋片 Defender -----	1
6	2210001352	軸 Shaft -----	1
7	2210001353	防油蓋 Cover -----	1
8	2210001311	孔塞 Plug -----	1
9	2210001310	油線 Oil Tube -----	1
10	8MM04284007B	螺絲 Screw (CT1310 M4-0.7*40) -----	4
11	2200001311	封蓋 Oil Filter Cover -----	1
12	8MB04281207K	螺絲 Screw (CT0239 M4-0.7*12) -----	3
13	2200001313	O 形油環 O Ring -----	1
14	2100001521	過濾器 Oil Filter -----	1
15	2200001315	過濾器接頭 Oil Filter Joint -----	1
16	2200001316	扣簧 Filter Screen Clamp -----	1
17	2600001317	網板 Filter Screen -----	1
18	2200001318	羊毛氈 Felt -----	1
19	66790	油管 Oil Tube (Ø2.9 * Ø5 * 410 L) -----	1
20	8MN04280400A	螺絲 Screw(CT0229 M4-0.7*4) -----	3
21	2210001354	防油蓋 Cover -----	1
22	66792	油管 Oil Tube (Ø4.6 * Ø6.3 * 420 L)-----	1
23	2100001536	夾簧 Latch Spring -----	10
24	2220001324	壓出泵 Rotor Case -----	1
25	2220001325	單向閥 One Way Valve -----	1
26	66792	油管 Oil Tube (Ø4.6 * Ø6.3 * 110 L)-----	1
27	2260001327	油管接頭 Oil Tube Joint -----	1
28	66792	油管 Oil Tube (Ø4.6 * Ø6.3 * 35 L)-----	1
29	2100001535	油管接頭 Oil Tube Joint -----	5
30	2100001533	螺椿 Stud -----	3
31	2220001331	銷 Pin -----	1
32	66792	油管 Oil Tube (Ø4.6 * Ø6.3 * 30 L)-----	1
33	26000013331	油管 Oil Tube -----	1
34	66792	油管 Oil Tube (Ø4.6 * Ø6.3 * 220 L)-----	1
35	2600001335	螺椿 Stud -----	1
36	26000013361	螺椿 Stud -----	1
37	2100001534	墊圈 Washer -----	13
38	2200001338	螺椿 Stud -----	1
39	2220001339	止回閥座 Bracket -----	1
40	2220001340	油嘴 Oil Tube Joint -----	1

13. CXM2000/CXM2500/CXM4000/CXD3800 潤滑系統 Lubrication System

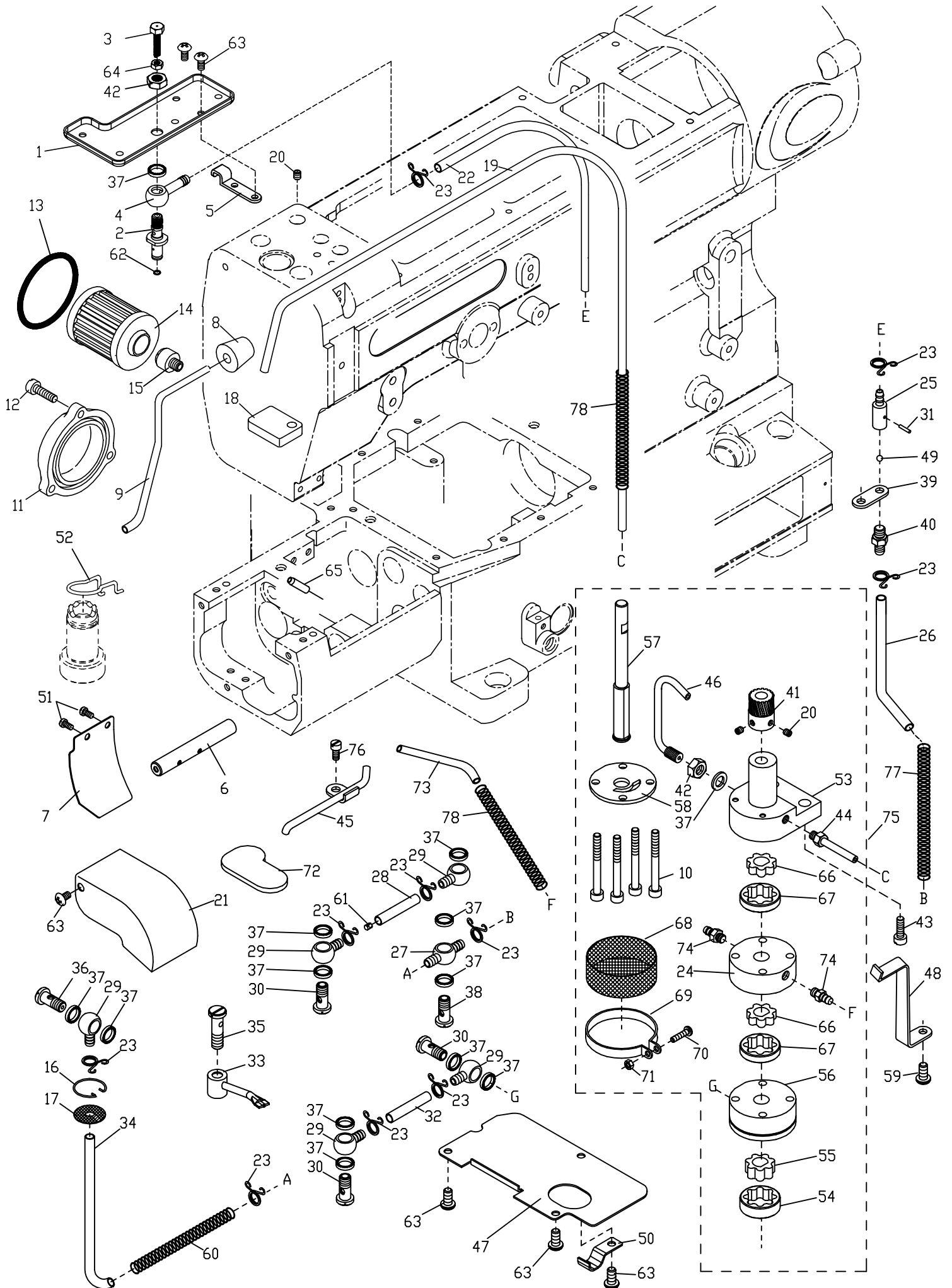

13. CXM2000 / CXM2500 / CXM4000 / CXD3800

潤滑系統 Lubrication System

序號 Ref.No.	物料編號 Parts No.	名稱 Description	單位用量 Amt. Req.
41	2200001341	螺母 Worm Gear -----	1
42	8MA06400510A	螺帽 Nut (CT0533 M6-1*5) -----	2
43	8MM06402010A	螺絲 Screw (SH04-44 M6-1*20) -----	2
44	2200001344	油管 Oil Tube -----	1
45	2600001345	油管 Oil Tube -----	1
46	22200013461	噴油嘴 Nozzle -----	1
47	26000013471	隔板 Separate -----	1
48	2220001348	油管支持臂 Oil Tube Holder -----	1
49	2220001349	鋼珠 Steel ball -----	1
50	2600001350	擋片 Defender -----	1
51	8MB03200506K	螺絲 Screw (CT0525 M3-0.5*5) -----	2
52	2270001352	壓簧 Pressing Latch -----	1
53	22200013531	回收泵 Pump Body -----	1
54	2200001354	外轉子 Outside Rotor -----	1
55	2200001355	內轉子 Inside Rotor -----	1
56	2200001356	壓出泵 Rotor Case -----	1
57	22200013571	軸 Shaft -----	1
58	2200001358	封蓋 Cover -----	1
59	8MC04280807D	螺絲 Screw (CT0130 M4-0.7*8) -----	1
60	2260001380	彈簧 Spring -----	1
61	66800	油線 Oil Wick (10 L)-----	1
62	90OR030	油環 Oil Rin -----	1
63	8MC04280507D	螺絲 Screw (CT0122 M4-0.7*5) -----	6
64	8MA85240306B	螺帽 Nut (FT020112 M3.5-0.6*2.8) -----	1
65	2200001365	油管 Oil Tube -----	1
66	2220001366	內轉子 Inside Rotor -----	2
67	2220001367	外轉子 Outside Rotor -----	2
68	2220001368	油網 Oil Mesh -----	1
69	2220001369	夾簧 Latch Spring -----	1
70	8MC03201306D	螺絲 Screw (UTB0335 M3-0.5*12.5) -----	1
71	8MA03200306A	螺帽 Nut(FTB0111 M3-0.5*3) -----	1
72	2220001372	羊毛氈 Felt -----	1
73	66790	油管 Oil Tube (Ø2.9 * Ø5 * 630 L)-----	1
74	2220001374	油嘴 Nozzle -----	2
75	227A0001375	泵組 Pump Asm -----	1
76	8MB04280608A	螺絲 Screw (UTB0130 M4-0.7*6) -----	1
77	2270001377	彈簧 Spring -----	1
78	22700013781	彈簧 Spring -----	2

14. 66707 線架 Thread Stand 66707

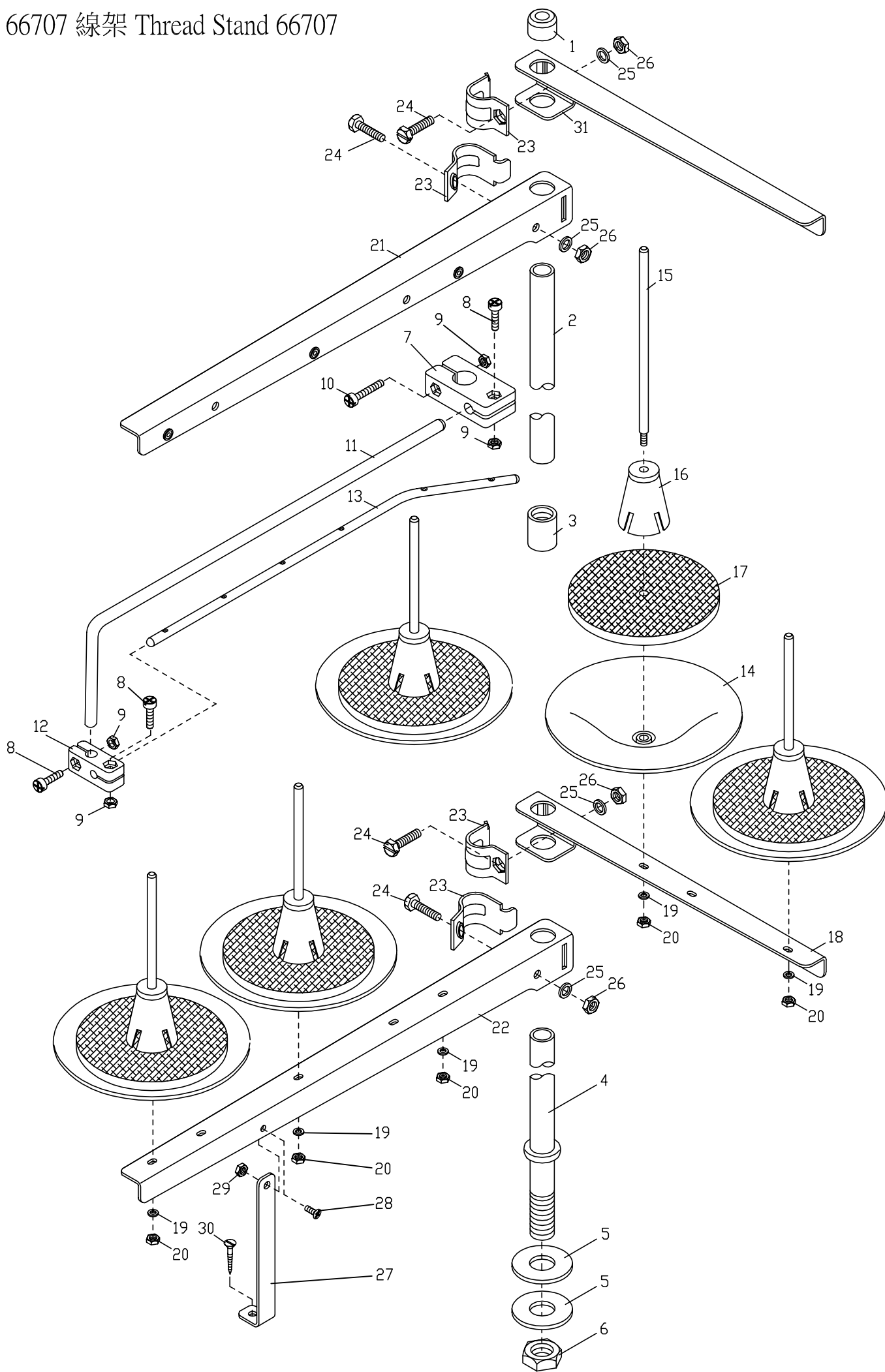

14. 66707 線架 Thread Stand 66707

序號 Ref.No.	物料編號 Parts No.	名稱 Description	單位用量 Amt. Req.
1	667051	柱帽 Rod Cup -----	1
2	667052	上柱 Upper Thread Stand Rod -----	1
3	667053	接頭 Joint -----	1
4	667054	下柱 Lower Thread Stand Rod -----	1
5	667055	墊圈 Washer -----	2
6	667056	螺帽 Nut -----	1
7	667057	接頭 Bracket -----	1
8	667058	螺絲 Screw -----	3
9	667059	螺帽 Nut -----	4
10	6670510	螺絲 Screw -----	1
11	6670511	旋臂 Arm -----	1
12	6670512	接頭 Bracket -----	1
13	6670513	導線桿 Thread Guide -----	1
14	6670514	線盤 Spool Set for SH6005 -----	5
15	6670515	線盤軸 Spool Pin -----	5
16	6670516	定心錐 Spool Retaining Fig -----	5
17	6670517	緩衝墊 Seat -----	5
18	667061	線盤座 Spool Set Bracket -----	1
19	6670519	彈簧墊圈 Spring Washer -----	5
20	6670520	螺帽 Nut -----	5
21	6670521	導線臂 Thread Guide -----	1
22	6670522	線盤座 Spool Set Bracket -----	1
23	6670523	夾板 Clamp -----	4
24	6670524	螺絲 Screw -----	4
25	6670525	彈簧墊圈 Spring Washer -----	4
26	6670526	螺帽 Nut -----	4
27	6670527	撐桿 Support Rod -----	1
28	6670528	螺絲 Screw -----	1
29	6670529	螺帽 Nut -----	1
30	6670530	木螺絲 Wood Screw -----	1
31	6670531	導線 Thread Guide -----	1

15. CTD9000 / CTU9011 / CXM2000 / CXM2500 / CXM4000 / CXU2000
 CXU2500 / CXU4000 裝載附件 Supporting Board

上載式

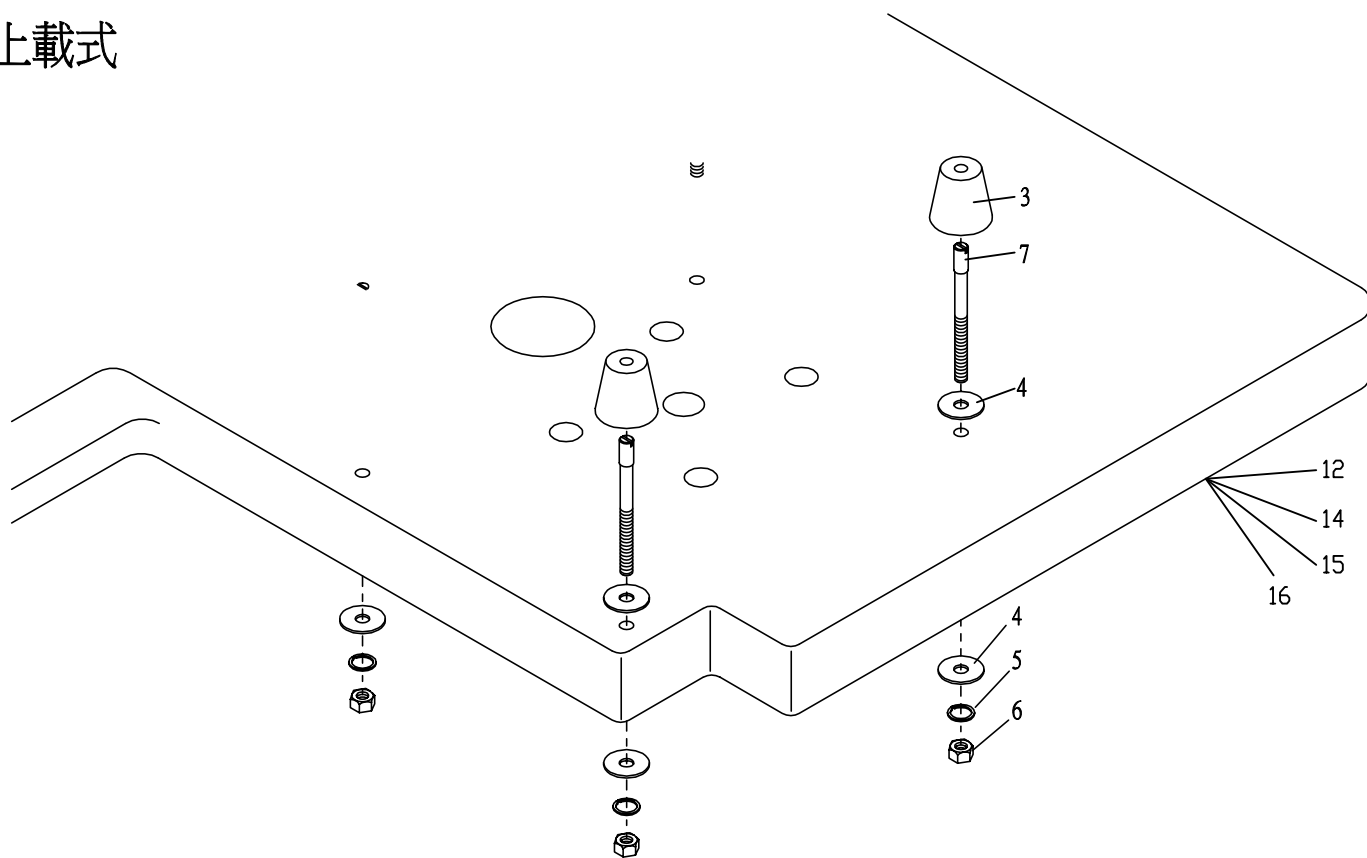

半沉式

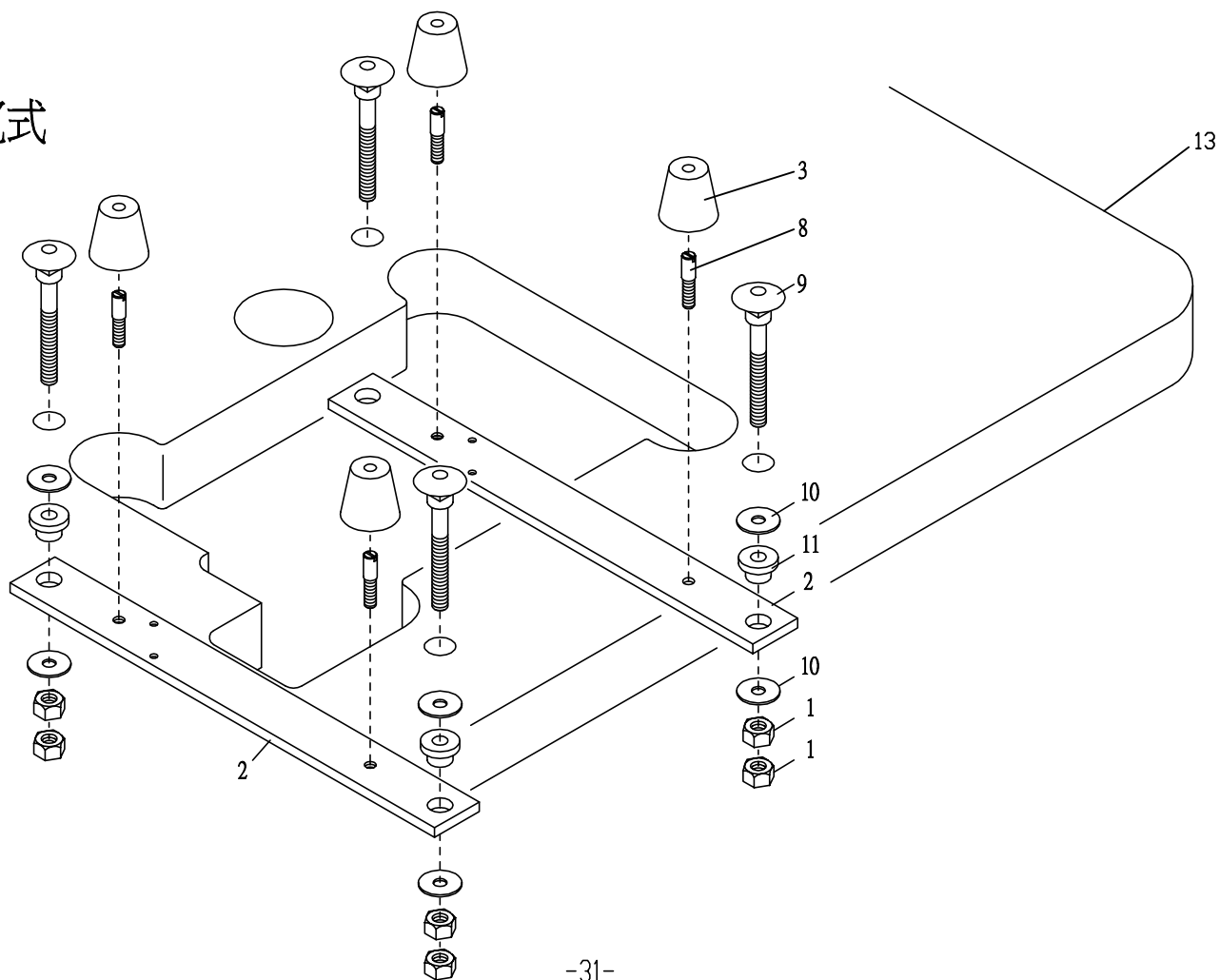

15. CTD9000 / CTU9011 / CXM2000 / CXM2500 / CXM4000
 CXU2000 / CXU2500 / CXU4000 裝載附件 Supporting Board

序號 Ref.No.	物料編號 Parts No.	名稱 Description	單位用量 Amt. Req.
*1	8SA79180613A	螺帽 Nut (CT1514 5/16"-18*6) -----	8
2	2200001512	車頭承板 Supporting Board -----	2
*3	66943	減震橡膠 Rubber Cushion -----	4
*4	2200001504	墊圈 Washer -----	8
*5	90SW070	彈簧墊圈 Spring Wahsher -----	4
*6	8MA06400612A	螺帽 Nut (SH0242 M6-1*6) -----	4
*7	8MB06406507B	螺椿 Bolt (CT1507 M6-1*65) -----	4
*8	8MB06401607M	螺椿 Stud (CT1503 M6-1*16) -----	4
*9	8SC79187827B	懸吊螺椿 Bolt -----	4
*10	2200001510	墊圈 Washer -----	8
*11	2200001511	橡膠環 Rubber Washer -----	4
12	66811-9	CTD9000/CTD9085/CTD9311/CTD9711/CTD9811/CXM2000/CXM2500/ CXM4000/CXM2311/CXM4311/CXU2000/CXU2500/CXU4000/CXU2311 CXU4311上載式開口型車板Open-cut Table Top Type -----	-
13	66811-10	CTD9000/CXM2000/CXM2500/CXM4000/CXM2311/CXM4311/CXU2000 CXU2500/CXU4000/CXU2311/CXU4311半沉式車板 Semi-submerged Type -----	-
14	66811-13	CTD9000/CTD9711/CXM2000/CXM2500/CXM4000/CXU2000/CXU2500 CXU4000上載式車板 Standard Table Top Type -----	-
15	66811-15	CTD9042 上載式開口型車板 Open-cut Table Top Type -----	-
16	66811-20	CXM2311/CXM4311/CXU2311/CXU4311 上載式車板 Standard Table Top Type -----	-
17	220A0001519	桌板螺絲包 Table Screw Package -----	1

* : 代表桌板螺絲包內的零件

16. CXM2500 工具及附件 Accesseries

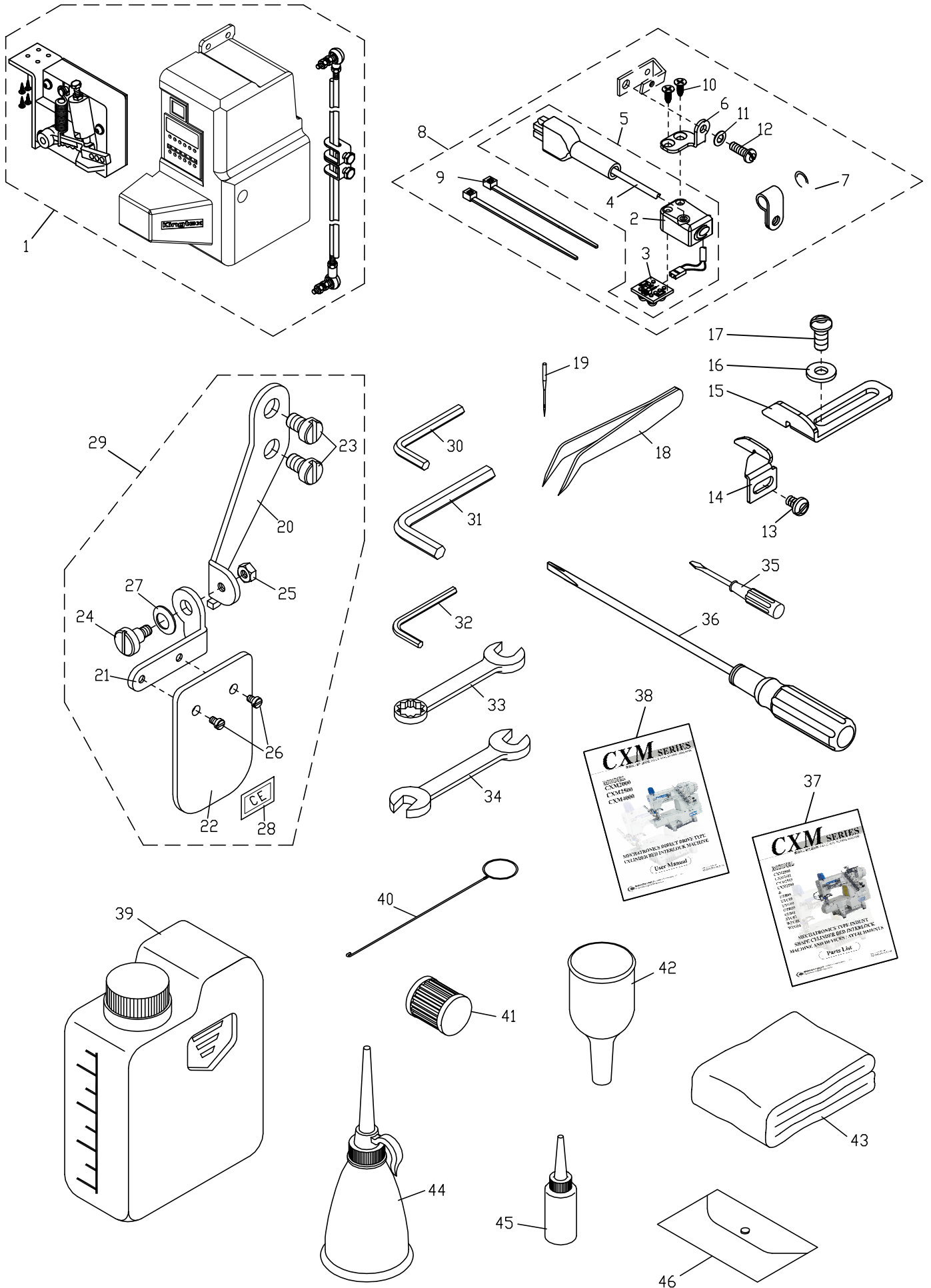

16. CXM2500 工具及附件 Accesseries





序號 Ref.No.	物料編號 Parts No.	名稱 Description	單位用量 Amt.Req.
1	-----	CXM2500 控制箱組 i60X-4-K1-220 Control Box Asm. -----	1
2	2240001602	燈座 Light holder bracket -----	1
3	2240001603	燈 LED light -----	1
4	2240001604	電源線 Power connector -----	1
*5	224A0001605	燈組 Light Asm. -----	1
6	2240001606	支架 Holder Bracket -----	1
7	4UTD000254	線夾 Cord Clamp -----	2
8	/TL001	燈組 LED Light Asm. -----	-
9	4UTB020306	束線 Plastic Binding Wire -----	2
10	8TE03440806A	螺絲 Screw -----	2
11	90DW040	碟形墊圈 Disk Washer -----	1
12	8MB04281007K	螺絲 Screw (CT1237 M4-0.7*10)-----	1
13	8MB03200406A	螺絲 Screw (UH01-31 M3-0.5*4) -----	1
14	2650110101	左導模 Fabric Guide (L)-----	1
15	2650110102	右導模 Fabric Guide (R)-----	1
16	2100000223	墊圈 Washer -----	1
17	8MB04280807K	螺絲 Screw (CT0215 M4-0.7*8) -----	1
18	66690	鑷子 Tweezer -----	1
19	66725-11-5	備用針 Retainer Needle -----	1
20	2200001620	護目鏡座 Safety Plate Support -----	1
21	2200001621	護目鏡架 Safety Plate Holder -----	1
22	2200001622	護目鏡 Safety Plate -----	1
23	8MC06401008E	螺絲 Screw (CT0832 M6-1*9.5) -----	2
24	8SB36400810E	螺絲 Screw (CT1624 9/64"-40*8) -----	1
25	8SA36400306A	螺帽 Nut (K09-09 9/64"-40*3) -----	1
26	8MB03200405A	螺絲 Screw (FT0548 M3-0.5*4) -----	2
27	2200000228	墊圈 Washer -----	1
28	66451	貼紙 Paster -----	1
29	220A0001632	護目鏡組 Safety Plate Asm. -----	1
30	66636	六角扳手 Spanner 3MM -----	1
31	66637	六角扳手 Spanner 4MM -----	1
32	66639	六角扳手 Spanner 1.5MM -----	1
33	66612	梅花扳手 Wrench 10MM -----	1
34	66613	開口扳手 Wrench 7/8MM -----	1
35	66667	小起子 Screw Driver (Small) -----	1
36	66671	木柄一字起子 Wooden Handle Flat Screw Driver -----	1
37	6CXM630A-B-25-06	零件冊 Parts List -----	-
38	6CXM62MA-08-25-08	使用說明書 Instruction Manual -----	-
39	66715	油罐 Oil Container -----	1
40	66840	穿線鋼絲 Threading Bar -----	1
41	2100001521	過濾器 Oil Filter -----	1
42	66722	漏斗 Oil Funnel -----	1
43	66848	防塵罩 Mechine Cover -----	1
44	66721	油壺 Oiler -----	1
45	66720	矽油 Silicon Oil -----	1
46	66831	工具袋 Bag -----	1

* 需整組購買 Must be sold in complete set

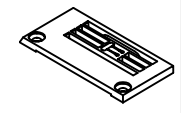
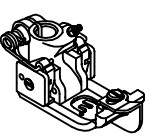
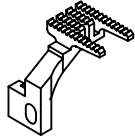
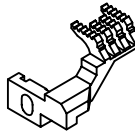
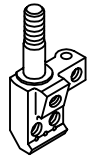
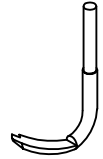
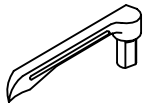

CXM2500 GAUGE PARTS LIST

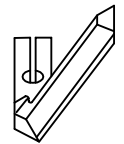
CXM2500-0-0 □□□M
 CXM2500-0-□□□M

Subclass / Remark	Date
	2026/01/27

Main Parts 更換零件	針數 Needle	針距 m.m	 Throat plate 針板	 Presser foot asm 壓腳	 Main feed dog 主送布齒	 Diff feed dog 副送布齒	 Needle clamp 針留	 Upper looper 上結線鉤	 Lower looper 下結線鉤	 Needle guide 前導針	 Needle guide 後導針	 Needle 針	
													5220FD00563 / 5265DF00560 組件 5265DG0001
	2	4.0	5222TP00401	5220PF00404			5220NC00400						
	3	4.8	5220TP00484	5220PF00485			5220NC00485	5220SL00560	5220LL00560	5220NG00563	5220NG00562	UY128GAS # 11	
	3	5.6	5220TP00564	5220PF00564			5227NC00560						
	3	6.4	5220TP00642	5220PF00644	5220FD00643	5265DF00640	5227NC00640						
					5265DG0002								

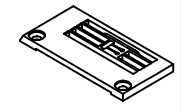
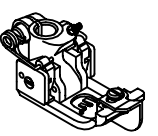
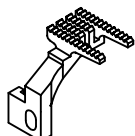
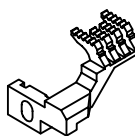
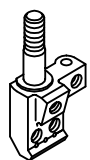
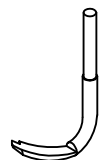
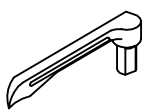
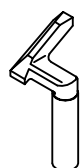
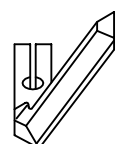



CXM2500-0-0 □□□H
 CXM2500-0-□□□H

Main Parts 更換零件	針數 Needle	針距 m.m	 Throat plate 針板	 Presser foot asm 壓腳	 Main feed dog 主送布齒	 Diff feed dog 副送布齒	 Needle clamp 針留	 Upper looper 上結線鉤	 Lower looper 下結線鉤	 Needle guide 前導針	 Needle guide 後導針	 Needle 針
	2	4.0	5222TP00400	5220PF00404			5220NC00400					
	3	4.8	5222TP00480	5220PF00485			5220NC00485	5220SL00560	5220LL00560	5220NG00563	5220NG00562	UY128GAS # 14
	3	5.6	5220TP00566	5220PF00564			5227NC00560					
	3	6.4	5220TP00644	5220PF00644	5220FD00643	5265DF00640	5227NC00640					
					5265DG0002							



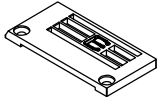

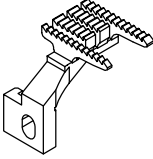
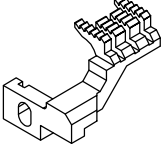
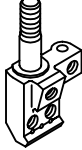
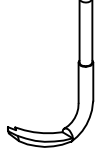
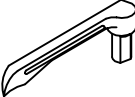
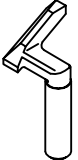
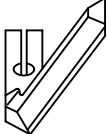
CXM2500 GAUGE PARTS LIST

CXM2500-0-0 □□□H1
 CXM2500-0- □□□H1

Subclass / Remark	Date
	2026/01/27

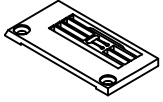
針 數 Needle	Main Parts 更換 零件 針 距 m.m										
		Throat plate 針板	Presser foot asm 壓腳	Main feed dog 主送布齒	Diff feed dog 副送布齒	Needle clamp 針留	Upper looper 上結線鉤	Lower looper 下結線鉤	Needle guide 前導針	Needle guide 後導針	Needle 針
3	5.6	5260TP00562	5220PF00564	5260FD00560	5265DF00561	5227NC00560	5220SL00560	5220LL00560	5220NG00563	5220NG00562	UY128GAS # 14
				5265DG0003							

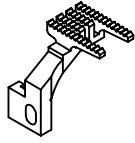
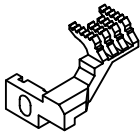
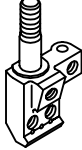
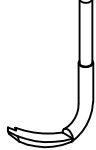
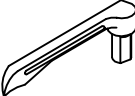
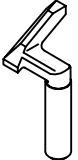
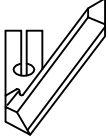
CXM2500-0-0 □□□W
 CXM2500-0- □□□W

針 數 Needle	Main Parts 更換 零件 針 距 m.m										
		Throat plate 針板	Presser foot asm 壓腳	Main feed dog 主送布齒	Diff feed dog 副送布齒	Needle clamp 針留	Upper looper 上結線鉤	Lower looper 下結線鉤	Needle guide 前導針	Needle guide 後導針	Needle 針
3	5.6	5220TP00568	5220PF00564	5220FD00563	5265DF00560	5227NC00560	5220SL00560	5220LL00560	5220NG00563	5220NG00562	UY128GAS # 11
				5265DG0001							
3	6.4	5220TP00646	5220PF00644	5220FD00643	5265DF00640	5227NC00640					
				5265DG0002							

CXM2500 GAUGE PARTS LIST

CXM2500-0-0□□□L
CXM2500-0-□□□L

Subclass / Remark	Date
	2026/01/27

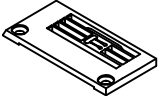
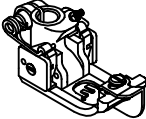
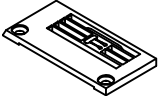
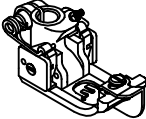
針數 Needle	針距 m.m	Main Parts 更換零件		Main feed dog 主送布齒	Diff feed dog 副送布齒	Needle clamp 針留	Upper looper 上結線鉤	Lower looper 下結線鉤	Needle guide 前導針	Needle guide 後導針	Needle 針	
												
2	4.0			5220FD00563 / 5265DF00560 組件 5265DG0001	5227NC00560	5220NC00400	5220SL00560	5220LL00560	5220NG00563	5220NG00562	UY128GAS # 11	
2	4.8	5222TP00481	5220PF00484									5220NC00480
3	4.8	5222TP00481	5220PF00485									5220NC00485
3	5.6	5222TP00560	5220PF00564									5227NC00560
3	6.4	5222TP00640	5220PF00644									5227NC00640

CXM2500-0-0□□□S
CXM2500-0-□□□S

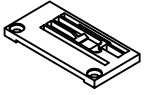
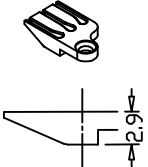
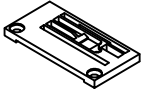
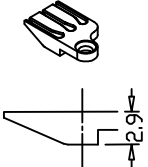
針數 Needle	針距 m.m	Main Parts 更換零件		Main feed dog 主送布齒	Diff feed dog 副送布齒	Aux feed dog 輔助送布齒	Needle clamp 針留	Upper looper 上結線鉤	Lower looper 下結線鉤	Needle guide 前導針	Needle guide 後導針	Needle 針
												
2	4.0			5222FD00560 / 5265DF00562 / 5222AF00560 組件 5265DG0004	5227NC00560	5220NC00400	5220SL00560	5220LL00560	5220NG00563	5220NG00562	UY128GAS # 11	
2	4.8	5222TP0056B	5222TPL140A									5220PF00404
3	4.8	5222TP0056B	5222TPL148A									5220PF00484
3	5.6	5222TP0056B	5222TPL156A									5220PF00564
3	6.4	5222TP0056B	5222TPL164A									5220PF00644

CXM2500 GAUGE PARTS LIST

CXM2500-0-0 □□□S1
CXM2500-0- □□□S1

Subclass / Remark	Date
	2026/01/27

針數 Needle	針距 m.m	Main Parts 更換零件		Presser foot asm 壓腳	Main feed dog 主送布齒	Diff feed dog 副送布齒	Aux feed dog 輔助送布齒	Needle clamp 針留	Upper looper 上結線鉤	Lower looper 下結線鉤	Needle guide 前導針	Needle guide 後導針	Needle 針	
		Throat plate 針板	Stitch plate Tongue 針板舌											
2	4.0	5227TP0056B	5222TPL140C	5220PF00404	5222FD00560 / 5265DF00562 / 5222AF00560 組件 5265DG0004			5220NC00400	5220SL00560	5220LL00560	5220NG00563	5220NG00562	UY128GAS # 11	
		5227TP00403												
2	4.8	5227TP0056B	5222TPL148C					5220PF00484						5220NC00480
		5227TP00483												
3	4.8	5227TP0056B	5222TPL148C					5220PF00485						5220NC00485
		5227TP00483												
3	5.6	5227TP0056B	5222TPL156C	5220PF00564	5227NC00560									
		5227TP00563												
3	6.4	5227TP0056B	5222TPL164C	5220PF00644	5227NC00640									
		5227TP00643												

CXM2500-0-0 □□□S2
CXM2500-0- □□□S2



針數 Needle	針距 m.m	Main Parts 更換零件		Presser foot asm 壓腳	Main feed dog 主送布齒	Diff feed dog 副送布齒	Needle clamp 針留	Upper looper 上結線鉤	Lower looper 下結線鉤	Needle guide 前導針	Needle guide 後導針	Needle 針
		Throat plate 針板										
3	5.6	5260TP00560		5220PF00564	5260FD00560 / 5265DF00561 組件 5265DG0003		5227NC00560	5220SL00560	5220LL00560	5220NG00563	5220NG00562	UY128GAS # 11
							5227NC00640					
3	6.4	5260TP00640		5220PF00644								

* 6.4 的 S2 三款下軸護蓋, 通用 5.6 S2 款的

CXM2500 / CXM2511 GAUGE PARTS LIST

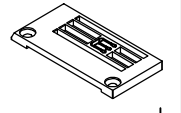
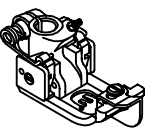
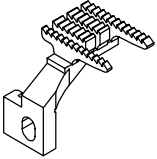
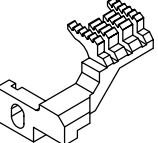
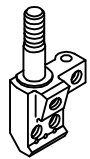
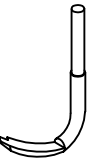

CXM2500-0-0 □□□S3
 CXM2500-0- □□□S3

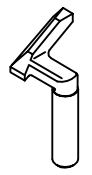
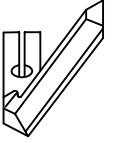
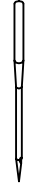
Subclass / Remark	Date
	2026/01/27

Main Parts 更換零件	針距 Needle m.m										
3	5.6	5260TP00561	5220PF00564	5260FD00560 / 5265DF00561 組件		5227NC00560	5220SL00560	5220LL00560	5220NG00563	5220NG00562	UY128GAS # 11
3	6.4	5260TP00641	5220PF00644	5265DG0003		5227NC00640					

* 6.4的S3三款下軸護蓋, 通用5.6 S3 款的

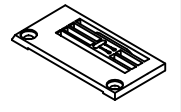
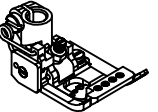
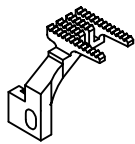
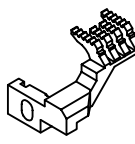
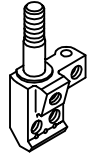
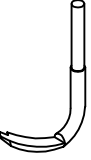
CXM2511-0- □□□M

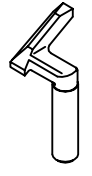
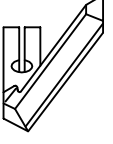
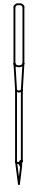
Main Parts 更換零件	針距 Needle m.m										
2	4.0	5222TP00401	5222PF11400	5220FD00563 / 5265DF00560		5220NC00400	5220SL00560	5220LL00560	5220NG00563	5220NG00562	UY128GAS # 11
2	4.8	5220TP00484	5222PF11480	組件		5220NC00480					
3	5.6	5220TP00564	5222PF11560	5265DG0001		5227NC00560					
3	6.4	5220TP00642	5222PF11640	5220FD00643	5265DF00640	5227NC00640					
				5265DG0002							

CXM2513 GAUGE PARTS LIST

Subclass / Remark	Date
	2026/01/27

CXM2513-0-□□□M

Main Parts 更換零件	針距 Needle m.m	針板 Throat plate	壓腳 Presser foot asm	主送布齒 Main feed dog	副送布齒 Diff feed dog	輔助送布齒 Aux feed dog	針留 Needle clamp	上結線鉤 Upper looper	下結線鉤 Lower looper	前導針 Needle guide	後導針 Needle guide	針 Needle
2	4.0	5222TP13403	5220PF00404	組件 5265DG0005			5220NC00485	5220SL00560	5220LL00560	5220NG00563	5220NG00562	UY128GAS # 11
3	4.8	5222TP13483	5220PF00485				5227NC00560					
3	5.6	5222TP13563	5220PF00564				5227NC00640					
3	6.4	5222TP13643	5220PF00644	5220FD00643	5265DF13640 5265DG0006	5220AF13640	5227NC00640					







CXM2513-1-□□□M

Main Parts 更換零件	針距 Needle m.m	針板 Throat plate	壓腳 Presser foot asm	主送布齒 Main feed dog	副送布齒 Diff feed dog	輔助送布齒 Aux feed dog	針留 Needle clamp	上結線鉤 Upper looper	下結線鉤 Lower looper	前導針 Needle guide	後導針 Needle guide	針 Needle
2	4.0	5222TP13404	5220PF00404	組件 5265DG0007			5220NC00485	5220SL00560	5220LL00560	5220NG00563	5220NG00562	UY128GAS # 11
3	4.8	5222TP13484	5220PF00485				5227NC00560					
3	5.6	5222TP13564	5220PF00564				5227NC00640					
3	6.4	5222TP13644	5220PF00644	5220FD00643	5265DF13640 5265DG0008	5220AF13561	5227NC00640					

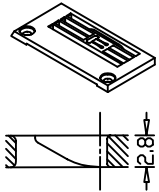
CXM2513 GAUGE PARTS LIST

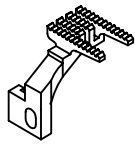
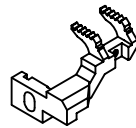
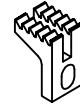
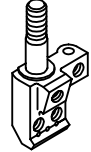
Subclass / Remark	Date
	2026/01/27

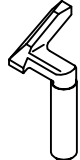
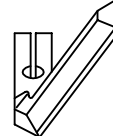
CXM2513-2-□□□M

Main Parts 更換零件 針距 Needle m.m	Main Parts 更換零件 針距 Needle m.m											
2	4.0	5222TP13402	5220PF00404	5220FD00563 / 5265DF13560 / 5220AF13560			5220NC00400	5220SL00560	5220LL00560	5220NG00563	5220NG00562	UY128GAS # 11
3	4.8	5222TP13482	5220PF00485	組件 5265DG0005			5220NC00485					
3	5.6	5222TP13562	5220PF00564				5227NC00560					
3	6.4	5222TP13642	5220PF00644	5220FD00643	5265DF13640 5265DG0006	5220AF13640	5227NC00640					



NTD7701
4-Needle, 6-Thread Flat-Seamer,
Feed-Off-The-Arm Machine



MT4512P-050 / PMD / FR01
12-Needle Double Chain Stitch Machine
(Lower Feed Metering Device \ Elastic hemmer)



UHU9304/TR025
Automatic chain cutter device direct-drive
cylinder bed top feed overlock fitted with
labor-saving rib folder

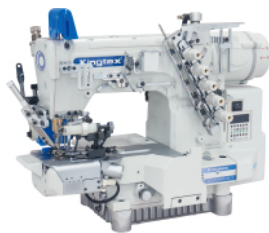

CXM2085-0-356M
Attaching Pre-Closed Flat Knit Elastic Band
Onto Waists Of Tubular Goods
(With Right Knife, Rear Puller & Chips Suction Pipe)



精機機械廠股份有限公司
CHING CHI MACHINE CO., LTD.

The specification and / or appearances of the equipment described
in this catalogue are subject to be changed without prior notice.

本目錄所述產品，因更新或改良，可能不事前預告，而對產品之外觀、規格、內容有所修改，特此聲明敬告請鑒亮。

