

MT SERIES

寶獅牌工業用縫紉機 INDUSTRIAL SEWING MACHINE

MODEL
MT4600
MTD4600

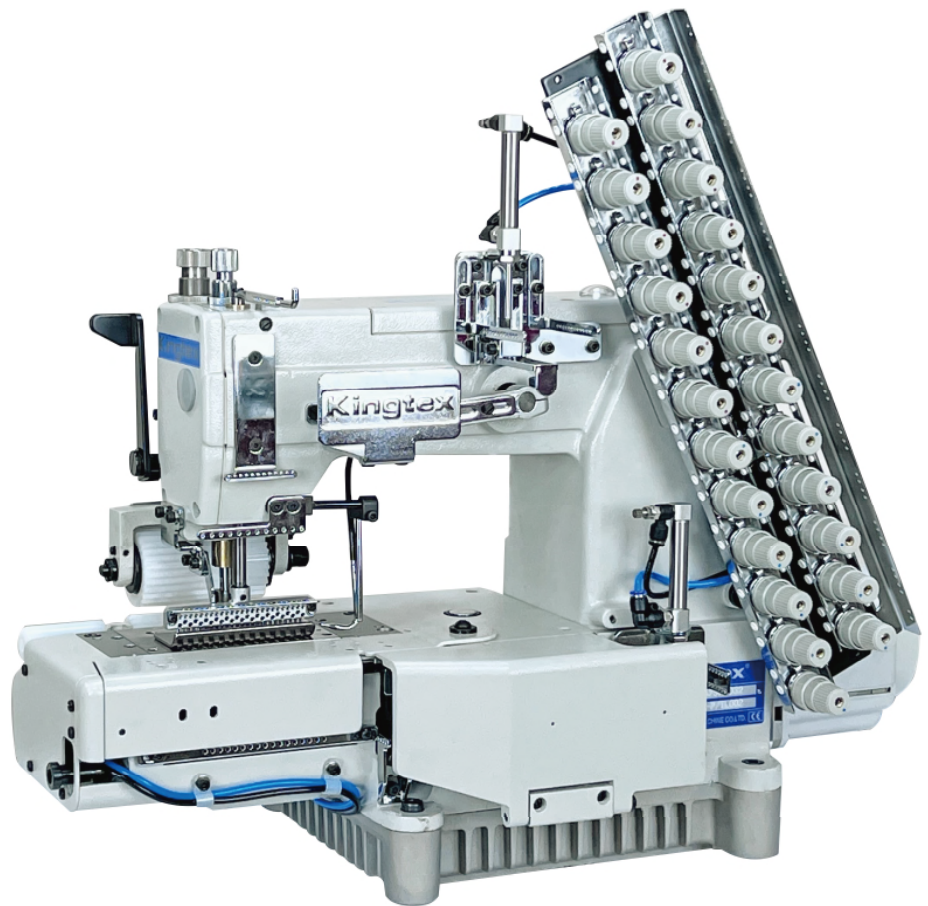

MULTI-NEEDLE DOUBLE CHAIN STITCH MACHINE

Parts List



MT4600 CONTENTS

序號 Ref. No.	名 稱 Description	頁次 Page No.
1	MT4500 / MT4600 本體外裝零件 Frame Components (一) -----	1
2	MT4500 / MT4600 本體外裝零件 Frame Components (二) -----	3
3	MT4501 / MT4504 / MT4601 / MT4604 張力調整零件 Thread Tension Mechanism -----	5
4	MT4506-MT4525 / MT4606-MT4625 張力調整零件 Thread Tension Mechanism -----	7
5	MT4500 / MT4600 軸襯與油封 Bushing And Seal -----	9
6	MT4000 / MT4500 / MT4600 針棒與相關零件 Needle Bar Mechanism -----	11
7	MT4500 / MT4600 下軸與相關零件 Crankshaft Mechanism -----	13
8	MT4000 / MT4500 / MT4600 進給變換機構 Feed Mechanism -----	15
9	MT4600 結線鉤驅動機構 Looper Mechanism -----	17
10	MT4000 / MT4500 / MT4600 壓腳與相關零件 Presser Foot Mechanism -----	19
11	MT4000 / MT4500 / MT4600 潤滑系統 Lubrication Mechanism -----	21
12	MT4000 / MT4500 / MT4600 後引式拖輪機構 Rear Puller Mechanism -----	23
13	MT4001-MT4004 / MT4504 / MT4604 後引式拖輪機構 Rear Puller Mechanism -----	25
14	MT4006-MT4012 / MT4506-MT4525 / MT4606-MT4625 後引式拖輪機構 Rear Puller Mechanism -----	27
15	667091 線架 MT4501 / MT4601 用 Thread Stand Mechanism -----	29
15-1	66711-1 線架 MT4504 / MT4604 用 Thread Stand Mechanism -----	31
16	66711-5 & 66711-6 & 66711-7 線架 Thread Stand Mechanism MT4506-4525 / MT4606-MT4625 用 -----	33
17	MT4609-MT4625 鬆線機構 Tension Stand Mechanism -----	35
17-1	MT4506 / MT4606 鬆線機構 Tension Stand Mechanism -----	37
18	MT4500 / MT4600 定規零件 Gauge Parts -----	39
19	TR02A 擴張滾輪組零件列表 Part List For TR02A Roller Set -----	41
20	MT4000 / MT4500 / MT4600 / MTD4500 / MTD4600 裝載附件 Supporting Boar -----	43
21	MT4500 / MT4600 工具及附件 Accesseries -----	45
22	MT4500 / MT4600 車型定規列表 Gauge Parts List -----	47

1. MT4500 / MT4600 本體外裝零件 Frame Components (一)

Subclass / Remark	Date
	2026/03/05

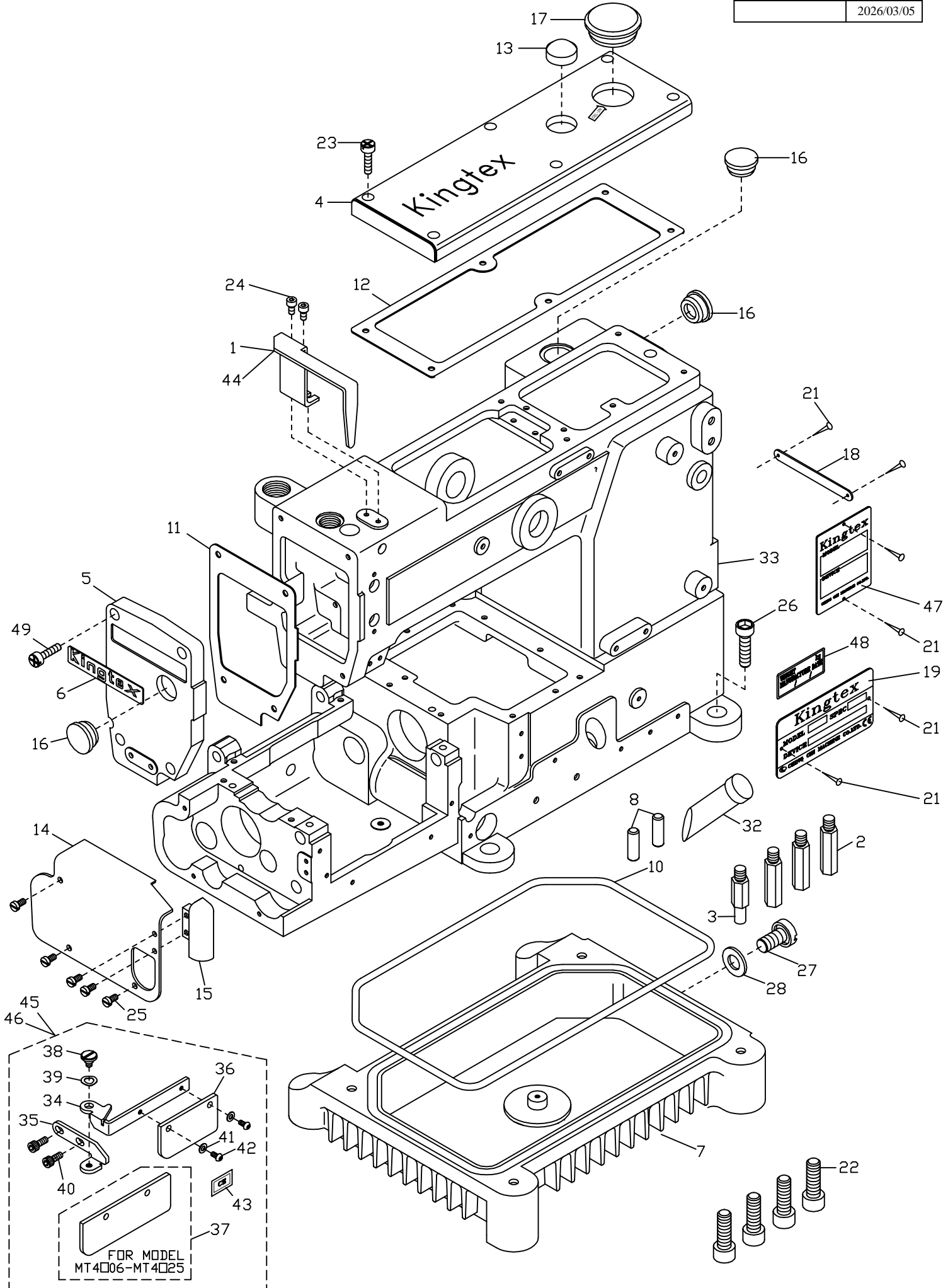

1. MT4500 / MT4600 本體外裝零件 Frame Components (一)

Subclass / Remark	Date
	2026/03/05

序號 Ref.No.	物料編號 Parts No.	名稱 Description	單位用量 Amt. Req.
*1	2310000101	針棒護蓋 Needle Cover -----	1
2	2310000102	下座腳樁 Supporting Bar -----	3
3	2310000103	下座腳樁 Supporting Bar -----	1
4	2310000104	上軸蓋 Top Cover -----	1
5	23100001051	針棒蓋 Needle Cover -----	1
6	23100001061	銘板 Plate -----	1
7	2310000107	油盤 Oil Reservoir -----	1
8	2310000108	銷 Pin -----	2
9	-----	-----	-
10	2310000110	油封 Gasket -----	1
11	23100001111	油封 Gasket -----	1
12	2310000112	油封 Gasket -----	1
13	2310000113	油鏡 Oil Window -----	1
14	2310000114	下座外蓋 Cloth Plate -----	1
15	2310000115	定位塊 Bracket -----	1
16	23100001161	孔塞 Plug -----	3
17	22000001051	孔塞 Plug (CT01051)-----	1
18	66477-1	機器號碼牌 Machine No. Plate -----	1
19	66485-2	車型銘板 Plate -----	1
20	-----	-----	-
21	66620	鉚釘 Rivet -----	6
22	8MM08502513A	螺絲 Screw (M8-1.25*25) (MT0122)-----	4
23	8MC04281207D	螺絲 Screw (CT0102 M4-0.7*12)-----	6
24	8MM04280807A	螺絲 Screw (M4-0.7*8) (MT0124) -----	2
25	8MB04280807K	螺絲 Screw (CT0215 M4-0.7*8) -----	5
26	8MM08502013A	螺絲 Screw (CT0106 M8-1.25*20) -----	4
27	8SM95281017A	螺絲 Screw (SH0243 3/8"-28*10) -----	1
28	2100000244	墊圈 Washer (SH0244)-----	1
29	-----	-----	-
30	-----	-----	-
31	-----	-----	-
32	2110001507	油面鏡 Oil Sign Gauge (R6031507) -----	1
33	2310000133	車頭 Frame Unit -----	1
34	2310000134	護目鏡支架 Bracket -----	1
35	2310000135	固定座 Bracket -----	1
36	2310000136	護目鏡 Safety Plate (MT4□04) -----	1
*37	2310000137	護目鏡 Safety Plate (MT4□06-4□25) -----	1
38	2310000138	螺樁 (Stud)-----	1
39	2310000139	波形墊圈 Washer -----	1
40	8MM04281007A	螺絲 Screw (FT0203 M4-0.7*10) -----	2
41	90PW030	墊圈 Washer (CT030211) -----	2
42	8MP03200606A	螺絲 Screw (MT0142 M3-0.5*6) -----	2
43	66451	貼紙 Paster -----	1
44	2310000144	針棒護蓋 Needle Cover -----	1
45	231A0000145	護目鏡支架組 Bracket Asm (MT4□04) -----	1
*46	231A0000146	護目鏡支架組 Bracket Asm (MT4□06-4□25)-----	1
*47	66477-3	銘板 Plate -----	1
48	66477-4	重量貼紙 Weight Paster -----	1
49	8MC05321209D	螺絲 Screw (C850212 M5-0.8*12)-----	4

* For MT4□06-MT4□25 Use.

2. MT4500 / MT4600 本體外裝零件 Frame Componets (二)

Subclass / Remark	Date
	2026/03/05

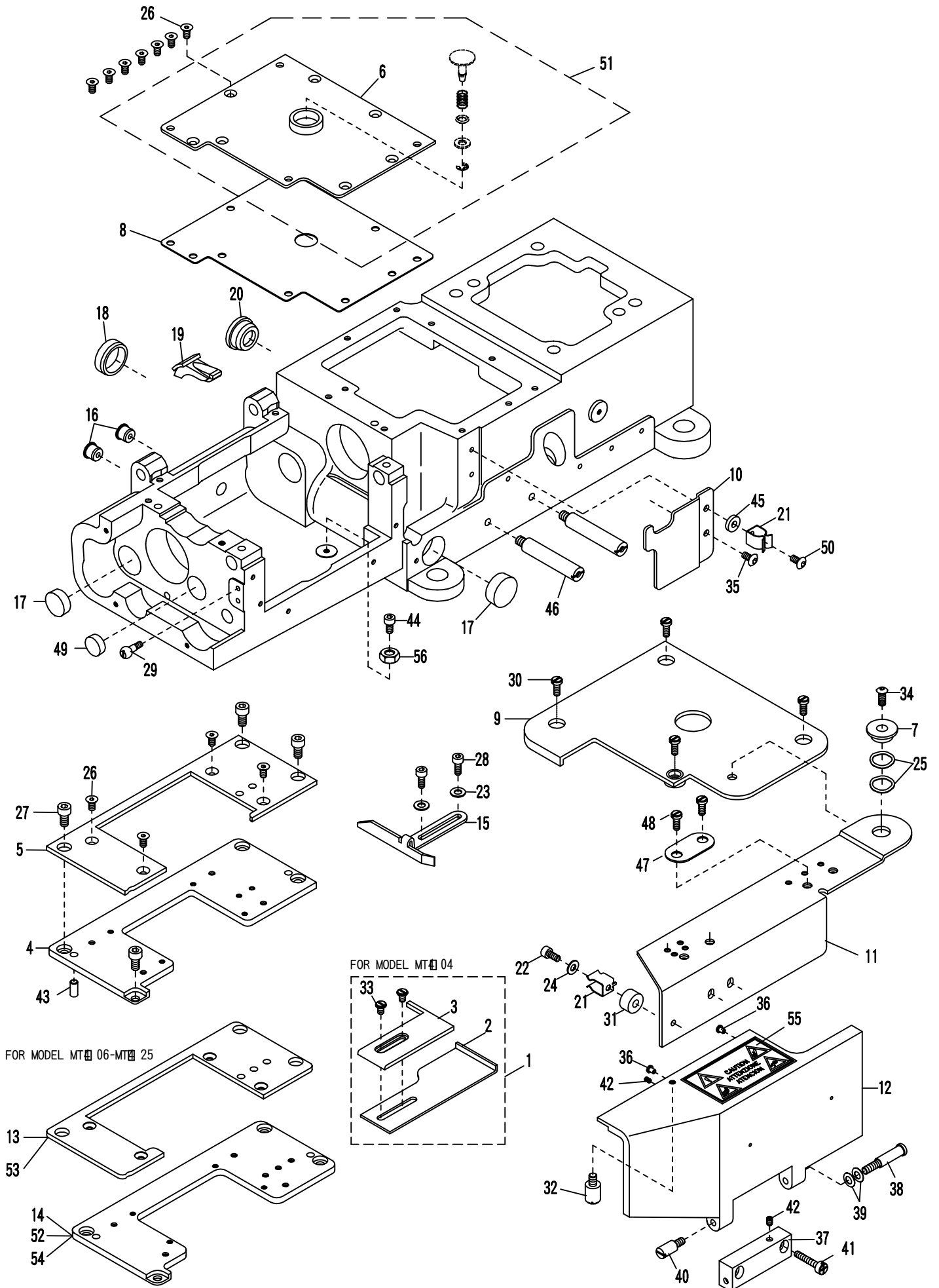

2. MT4500 / MT4600 本體外裝零件 Frame Components (二)

Subclass / Remark	Date
	2026/03/05

序號 Ref.No.	物料編號 Parts No.	名稱 Description	單位用量 Amt. Req.
1	231A0000201	導模組 Edge Guide Asm. (MT4□04)	1
2	23100002021	導模 Edge Guide	1
3	23100002031	導模 Edge Guide	1
4	2310000204	針板座 Needle Plae Seat	1
5	2310000205	封蓋 Cover	1
6	23100002061	下軸內蓋 Lower Shaft Cover	1
7	2310000207	隔環 Spacer	1
8	2310000208	防漏墊片 Gasket	1
9	2310000209	下座外蓋 Cloth Plate	1
10	23100002101	檔片 Defender	1
11	2310000211	下座前蓋 Cloth Plate	1
12	2310000212	前蓋 Front Cover	1
*13	2310000213	封蓋 Cover	1
*14	2310000214	針板座 Needle Plate Seat	1
15	23100002151	導模 Edge Guide	1
16	22000001091	孔塞 Plug (CT0109)	2
17	23100002171	孔塞 Plug	2
18	22000002451	孔塞 Plug (CT0245)	1
19	23100002191	孔塞 Plug	1
20	23100001161	孔塞 Plug	1
21	2200000121	夾簧 Latch Spring (CT0121)	2
22	8MM04281207A	螺絲 Screw (CT0202 M4-0.7*12)	1
23	2100000223	墊圈 Washer (CT0232)	2
24	90SW040	彈簧墊圈 Spring Washer (UTB0317)	1
25	2310000225	波形墊圈 Corrugated Washer	2
26	8MQ04280808A	螺絲 Screw (UTB0109 M4-0.7*8)	11
27	8MM05321009A	螺絲 Screw (CT0626 M5-0.8*10)	4
28	8MM04281007A	螺絲 Screw (FT0203 M4-0.7*10)	2
29	8MD04281008C	螺絲 Screw (MT0229 M4-0.7*5)	1
30	8MB04281007K	螺絲 Screw (CT1237 M4-0.7*10)	4
31	2310000231	隔環 Spacer	1
32	2310000232	銷 Pin	1
33	8MB04280607K	螺絲 Screw (MT0233 M4-0.7*6)	2
34	8MP06401011A	螺絲 Screw (MT0234 M6-1*10)	1
35	8MP04280808A	螺絲 Screw (MT0235 M4-0.7*8)	1
36	22100001191	減震橡膠 Rubber Cushion (FT01191)	2
37	2200000224	絞鏈 Hinge (CT0224)	1
38	8MB04283809E	螺樁 Stud (CT0227 M4-0.7*38)	1
39	2200000228	孟形墊圈 Washer (CT0228)	2
40	8MB04280605M	螺絲 Screw (CT0230 M4-0.7*6)	1
41	8MC04281407D	螺絲 Screw (CT0225 M4-0.7*14)	2
42	8MN04280400A	螺絲 Screw (CT0229 M4-0.7*4)	3
43	2210090209	定位銷 Pin (FT0238)	2
44	8MM04280807A	螺絲 Screw (MT0124 M4-0.7*8)	1
45	2310000245	隔環 Spacer	1
46	2310000246	支撐桿 Supporting Rod	2
47	2310000247	墊片 Washer	1
48	8MC06400810A	螺絲 Screw (MT0248 M6-1*8)	2
49	23100002491	孔塞 Plug	1
50	8MP04281008A	螺絲 Screw (MT0250 M4-0.7*10)	1
51	231A0000251	下軸內蓋組 Lower Shaft Cover Asm.	1
**52	2310000252	針板座 Needle Plate Seat	1
***53	2310000253	封蓋 Cover	1
***54	2310000254	針板座 Needle Plate Seat	1
55	66455	貼紙 Paster	1
56	8MA04280307A	螺帽 Nut (CT0238 M4-0.7*3)	1

* : MT4□06-MT4□17 用 For MT4□06-MT4□17 Use

** : MT4□13P□-064 用 For MT4□13P□-064 Use

*** : MT4□25 用 For MT4□25 Use

3. MT4501 / MT4504 / MT4601 / MT4604 張力調整零件

Subclass / Remark	Date
	2026/03/05

Thread Tension Mechanism

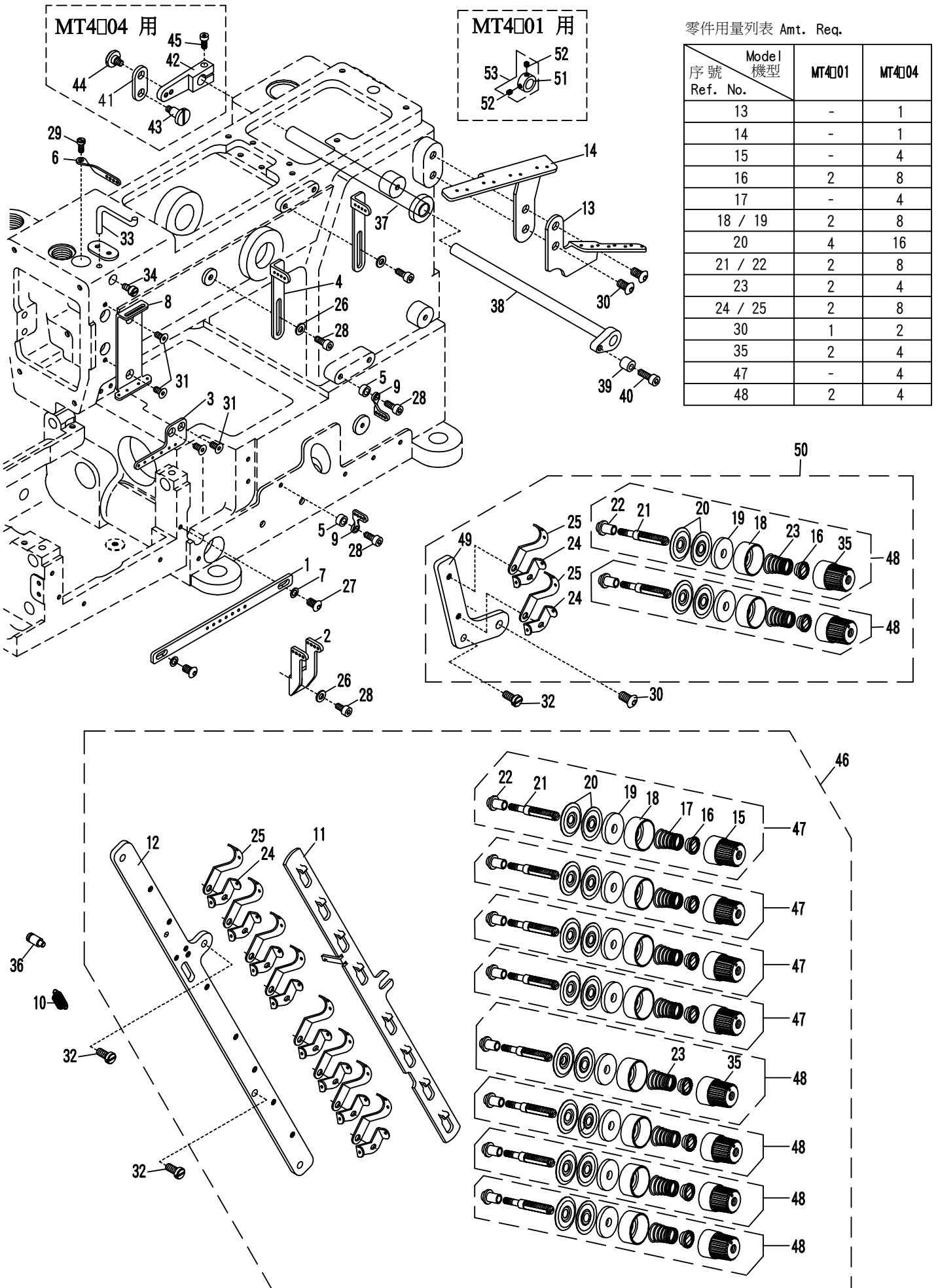

3. MT4501 / MT4504 / MT4601 / MT4604 張力調整零件

Subclass / Remark	Date
	2026/03/05

Thread Tension Mechanism

序號 Ref.No.	物料編號 Parts No.	名稱 Description	單位用量 Amt. Req.
1	2310000301	導線 Thread Guide -----	1
2	2310000302	導線 Thread Guide -----	1
3	2310000303	導線 Thread Guide -----	1
4	2310000304	導線 Thread Guide -----	2
5	2310000305	定位環 Collar -----	2
6	23100003061	導線 Thread Guide -----	1
7	2100000640	墊圈 Washer (SH0640) -----	2
8	2310000308	導線 Thread Guide -----	1
9	2310000309	導線 Thread Guide -----	2
10	2310000310	彈簧 Spring -----	1
11	2310000311	鬆線鉸 Release Wedge -----	1
12	23100003121	導線座 Tension Post Support -----	1
13	2310000313	導線 Thread Guide -----	-
14	2310000314	導線 Thread Guide -----	-
15	2100001121	張力調整螺帽 Tension Nut (Red) (SH1121) -----	-
16	2200000303	套管 Bushing (CT0303) -----	-
17	2100001123	彈簧 Spring (Red) (SH1123) -----	-
18	2200000305	彈簧座 Spring Set (CT0305)-----	-
19	2100001127	羊毛氈 Felt (SH1127) -----	-
20	2100001126	張力控制盤 Tension Disc (SH1126)-----	-
21	22000003081	螺樁 Stud -----	-
22	22000003091	隔環 Spacer -----	-
23	2100001132	彈簧 Spring (Bule)(See left Page)(SH1132) -----	-
24	2200000311	導線 Thread Guide (CT0311)-----	-
25	2200000312	導線 Thread Guide (CT0312)-----	-
26	2100000223	墊圈 Washer (CT0232)-----	3
27	8MP04280808A	螺絲 Screw (M4-0.7*8) (MT0235) -----	2
28	8MM04281007A	螺絲 Screw (FT0203 M4-0.7*10) -----	5
29	8MB04280807K	螺絲 Screw (CT0215 M4-0.7*8) -----	1
30	8MP06401211A	螺絲 Screw (UTB0302 M6-1*12) -----	-
31	8MQ04280808A	螺絲 Screw (UTB0109 M4-0.7*8) -----	4
32	8MC05321208A	螺絲 Screw (M5-0.8*12) (MT0332) -----	2
33	2310000333	導線 Thread Guide -----	1
34	8MB04280807K	螺絲 Screw (M4-0.7*8) (CT0215) -----	1
35	2100001121B	張力調整螺帽 Tension Nut (Bule) (See left Page)(SH1121) -----	-
36	2310001937	螺樁 Stud -----	1
37	2310000337	導管 Pipe -----	1
38	2310000338	軸 Shaft -----	1
39	2310000339	調整隔環 Spacer -----	1
40	8MM04281207A	螺絲 Screw (M4-0.7*12) (CT0202) -----	1
41	2310000341	連桿 Link -----	1
42	2310000342	曲柄 Lever -----	1
43	2310000343	螺樁 Stud -----	1
44	2310000344	螺樁 Stud -----	1
45	8MK95301407A	螺絲 Screw (M4.5-0.75*14) (CT0837) -----	1
46	231A0000346	鬆線組 Thread Tension Mechanism-----	1
47	231A0001922	張力調整組 Tension Asm. (Red) -----	-
48	231A0001923	張力控制組 Tension Set. (Bule)-----	-
* 49	2320000301	導線座 Tension Post Support -----	1
* 50	232A0000302	鬆線組 Thread Tension Mechanism-----	1
* 51	2210000534	定位環 Collar -----	1
* 52	8MN03200300A	螺絲 Screw (M3-0.5*3) (CT0115) -----	2
* 53	221A0000563	定位環組 Collar Asm.(F0534A)-----	1

* MT4□01 用 For MT4□01 Use

4. MT4506-MT4525 / MT4606-MT4625 張力調整零件 Thread Tension Mechanism

Subclass / Remark	Date
	2026/03/05

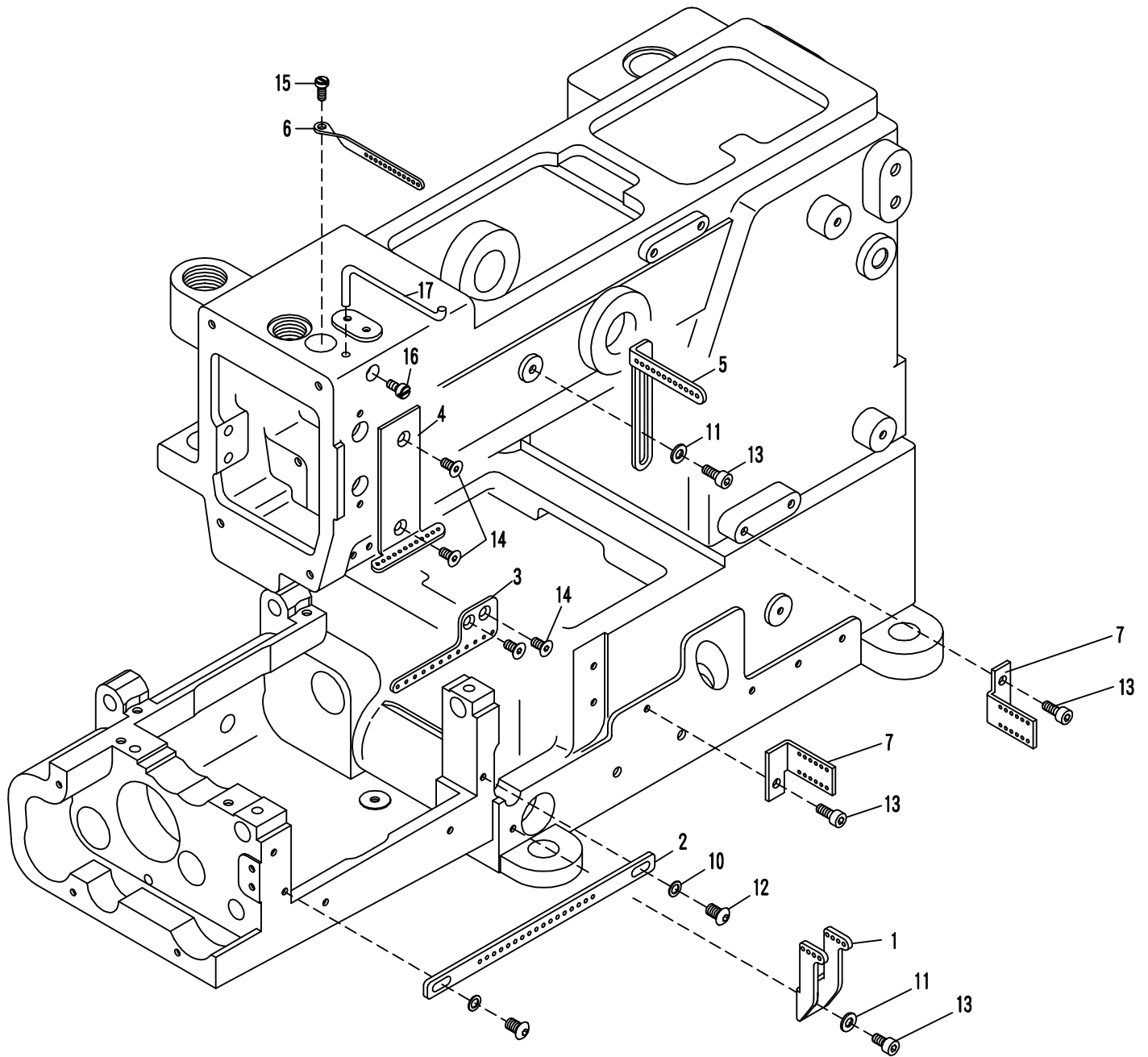

4. MT4506-MT4525 / MT4606-MT4625 張力調整零件

Subclass / Remark	Date
	2026/03/05

Thread Tension Mechanism

序號 Ref.No.	物料編號 Parts No.	名稱 Description	單位用量 Amt. Req.
1	2310000302	導線 Thread Guide -----	1
2	2310000402	導線 Thread Guide -----	1
3	2310000403	導線 Thread Guide -----	1
4	2310000404	導線 Thread Guide -----	1
5	2310000405	導線 Thread Guide -----	1
6	2310330406	導線 Thread Guide -----	1
7	2310000407	導線 Thread Guide -----	2
8	-----	-----	-
9	-----	-----	-
10	2100000640	墊圈 Washer (SH0640)-----	2
11	2100000223	墊圈 Washer (CT0232)-----	2
12	8MP04280808A	螺絲 Screw (M4-0.7*8) (MT0235) -----	2
13	8MM04281007A	螺絲 Screw (FT0203 M4-0.7*8) -----	4
14	8MQ04280808A	螺絲 Screw (UTB0109 M4-0.7*8) -----	4
15	8MB04280807K	螺絲 Screw (CT0215 M4-0.7*8) -----	1
16	8MB04280807K	螺絲 Screw (CT0215 M4-0.7*8) -----	1
17	2310000417	導線 Thread Guide -----	1

5. MT4500 / MT4600 軸襯與油封 Bushing And Seal

Subclass / Remark	Date
	2026/03/05

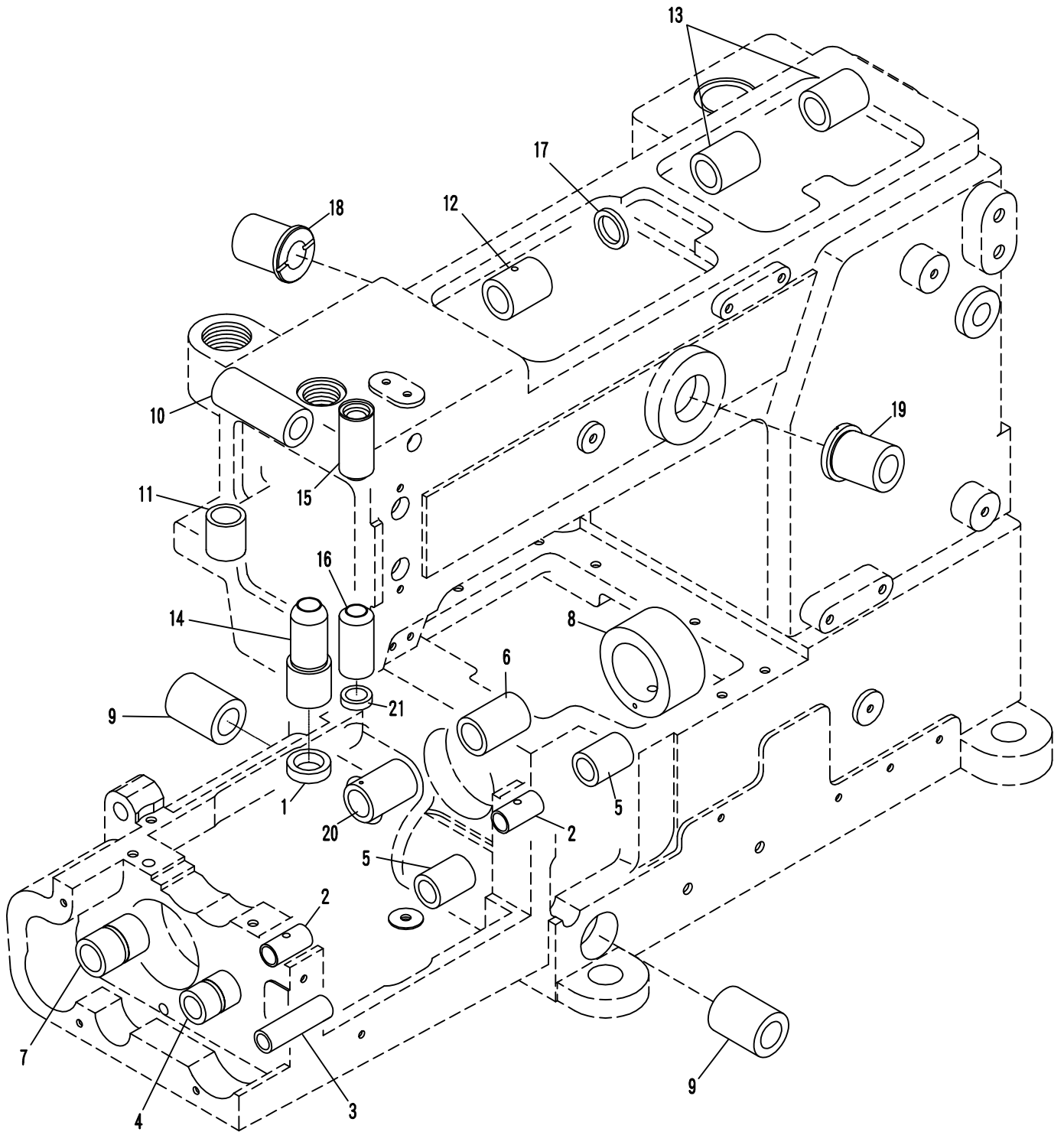

5. MT4500 / MT4600 軸襯與油封 Bushing And Seal

Subclass / Remark	Date
	2026/03/05

序號 Ref.No.	物料編號 Parts No.	名稱 Description	單位用量 Amt. Req.
1	2200000404	油封 Oil Seal (CT0404)-----	1
2	2310000502	軸襯 Bushing -----	2
3	2310000503	軸襯 Bushing -----	1
4	2310000504	軸襯 Bushing -----	1
5	2310000505	軸襯 Bushing -----	2
6	2310000506	軸襯 Bushing -----	1
7	2310000507	軸襯 Bushing -----	1
8	2310000508	軸襯 Bushing -----	1
9	2310000509	軸襯 Bushing -----	2
10	2310000510	軸襯 Bushing -----	1
11	2310000511	軸襯 Bushing -----	1
12	2310000512	軸襯 Bushing -----	1
13	2310000513	軸襯 Bushing -----	2
14	2310000514	軸襯 Bushing -----	1
15	2310000515	軸襯 Bushing -----	1
16	23100005161	軸襯 Bushing -----	1
17	2310000517	油封 Oil Seal -----	1
18	2310000518	軸襯 Bushing -----	1
19	23100005191	軸襯 Bushing -----	1
20	2310000520	軸襯 Bushing -----	1
21	240010004	油封 Oil Seal -----	1

6. MT4000 / MT4500 / MT4600 針棒與相關零件 Needle Bar Mechanism

Subclass / Remark	Date
	2026/03/05

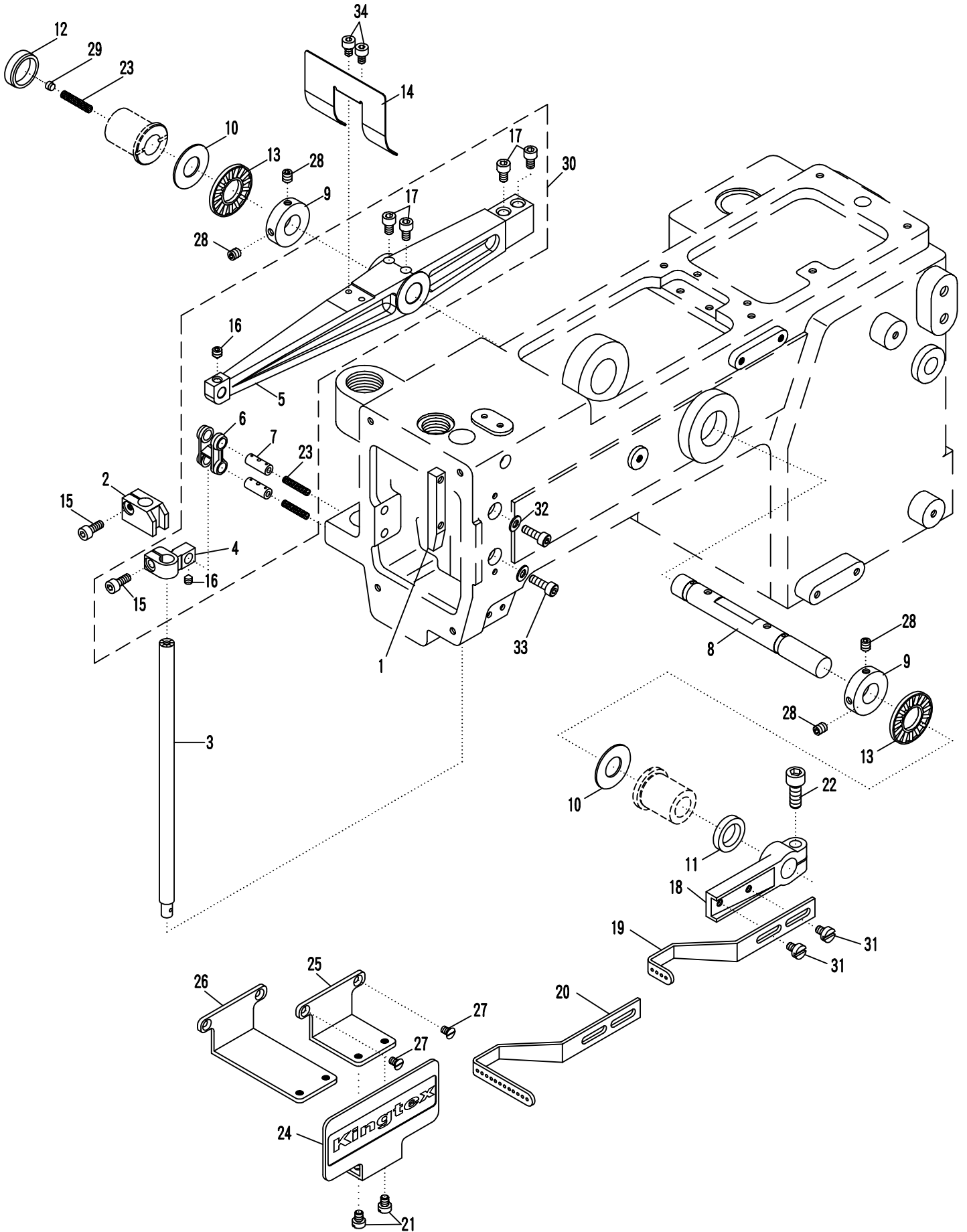

6. MT4000 / MT4500 / MT4600 針棒與相關零件

Subclass / Remark	Date
	2026/03/05

Needle Bar Mechanism

序號 Ref.No.	物料編號 Parts No.	名稱 Description	單位用量 Amt. Req.
1	2310000601	滑道 Guide Block -----	1
2	23100006021	滑塊 Slide Block -----	1
3	2310330603	針棒 Needle Bar -----	1
4	2310000604	連桿 Connecting Rod -----	1
5	23100006051	連桿 Connecting Rod -----	1
6	2310000606	連桿 Connecting Rod -----	1
7	2310000607	連接銷 Pin -----	2
8	2310000608	軸 Shaft -----	1
9	2310000609	定位環 Collar -----	2
10	2310000610	止推墊圈 Thrust Bearing -----	2
11	2310000611	油封 Oil Seal -----	1
12	22000002451	孔塞 Plug -----	1
13	2200001044	止推軸承 Thrust Bearing (CT1044)-----	2
14	2310000614	擋片 Defender -----	1
15	8MM04281007A	螺絲 Screw (FT0203 M4-0.7*10) -----	2
16	8MN04280500C	螺絲 Screw (M4-0.7*5) (FT1222) -----	2
17	8MM06401010A	螺絲 Screw (M6-1*10) (MT0419) -----	4
18	2310000618	導線固定座 Holder -----	1
19	2310000619	導線 Thread Guide -----	1
*20	2310000620	導線 Thread Guide -----	1
21	8MB04280608A	螺絲 Screw (UTB0130 M4-0.7*6) -----	2
22	8MM06401610A	螺絲 Screw (CT0625 M6-1*16) -----	1
23	66800	油線 Oil Wick-----	3
24	2310000624	護蓋 Cover -----	1
25	2310000625	護蓋固定座 Holder -----	1
*26	2310000626	護蓋固定座 Holder -----	1
27	8ME04280708A	螺絲 Screw (CT0206 M4-0.7*7) -----	2
28	8MN04280600A	螺絲 Screw (CT1223 M4-0.7*6) -----	4
29	2200001029	孔塞 Plug (CT1029)-----	1
30	231A00006301	連桿組 Connecting Rod Asm.-----	1
31	8MB04280807K	螺絲 Screw (CT0215 M4-0.7*8) -----	2
32	2100000223	墊圈 Washer (SH0223)-----	2
33	8MM04281207A	螺絲 Screw (C02-02 M4-0.7*12) -----	2
34	8MM04280607A	螺絲 Screw (MT1134 M4-0.7*6) -----	2

* For MT4006-MT4012 / MT4506-MT4525 / MT4606-MT4625 Use

7. MT4500 / MT4600 下軸與相關零件 Crankshaft Mechanism

Subclass / Remark	Date
	2026/03/05

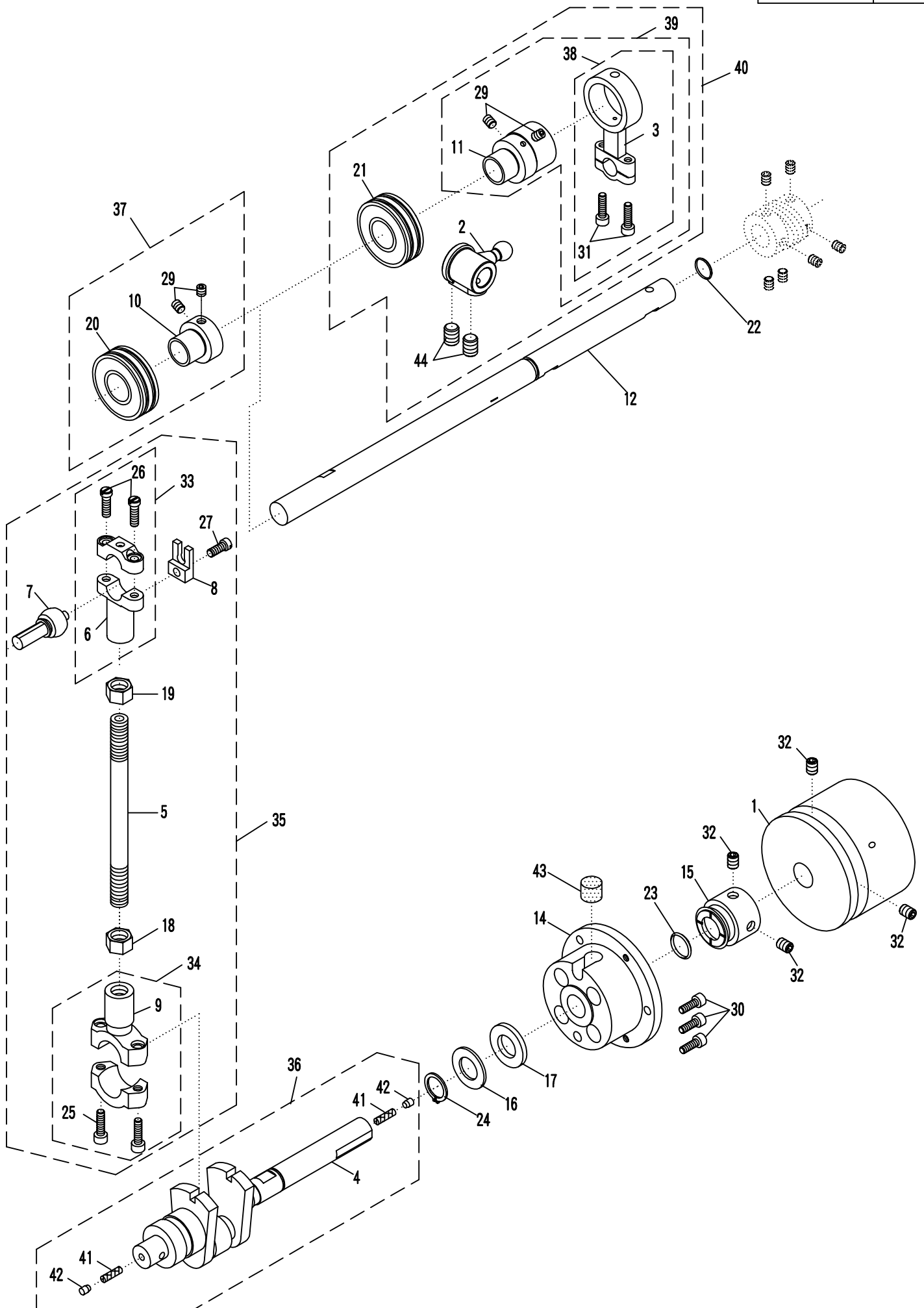

7. MT4500 / MT4600 下軸與相關零件 Crankshaft Mechanism

Subclass / Remark	Date
	2026/03/05

序號 Ref.No.	物料編號 Parts No.	名稱 Description	單位用量 Amt. Req.
1	23100007011	針定位皮帶輪 Belt Cover -----	1
2	23100007021	曲柄 Lever -----	1
3	2310000703	連桿 Connecting Rod -----	1
4	23100007041	曲軸 Crank Shaft -----	1
5	2310000705	螺椿 Stud -----	1
6	2310000706	連桿 Connecting Rod -----	1
7	2310000707	球狀接頭 Ball Stud -----	1
8	2310000708	定向導軌 Guide -----	1
9	2310000709	連桿 Connecting Rod -----	1
10	2310000710	套筒 Clutch Sleeve -----	1
11	2310000711	偏心輪 Eccentric -----	1
12	2310000712	軸 Shaft -----	1
13	-----	-----	-
14	2310000714	鋁蓋 Cover -----	1
15	2310000715	定位環 Collar -----	1
16	2310000716	墊圈 Washer -----	1
17	2310000717	墊圈(銅) Washer -----	1
18	2310000718	螺帽 Nut -----	1
19	2310000719	螺帽 Nut -----	1
20	90BB1740126	滾珠軸承 Ball Bearing (MT0720) 封蓋為鐵的-----	1
21	90BB1740126R	滾珠軸承 Ball Bearing (MT0720-R) 封蓋為紅色-----	1
22	2310000722	O形油環 O Ring (線徑 ϕ 1.2) -----	1
23	90OR140	O形油環 O Ring (線徑 ϕ 2.4) -----	1
24	90SCR140	C形扣環 C Ring -----	1
25	8MB95301807K	螺絲 Screw (MT0725 M4.5-0.75*18) -----	2
26	8MB95301507K	螺絲 Screw (MT0726 M4.5-0.75*15) -----	2
27	8MB95301106K	螺絲 Screw (MT0727 M4.5-0.75*11) -----	1
28	-----	-----	-
29	8MN05320600A	螺絲 Screw (MT0729 M5-0.8*6) -----	4
30	8MM04281007A	螺絲 Screw (FT0203 M4-0.7*10) -----	3
31	8MM04281407A	螺絲 Screw (FT1003 M4-0.7*14) -----	2
32	8MN06400800A	螺絲 Screw (CT0549 M4-0.7*8) -----	4
33	231A0000733	連桿組 Connecting Rod Asm. -----	1
34	231A0000734	連桿組 Connecting Rod Asm. -----	1
35	231A0000735	連桿組 Connecting Rod Asm. -----	1
36	231A0000736	曲軸組 Crank Shaft Asm. -----	1
37	231A0000737	連桿組 Connecting Rod Asm. -----	1
38	231A0000738	連桿組 Connecting Rod Asm. -----	1
39	231A0000739	連桿組 Connecting Rod Asm. -----	1
40	231A00007401	偏心輪組 Eccentric Asm. -----	1
41	66800	油線 Oil Wick -----	2
42	2200001029	孔塞 Plug (CT1029)-----	2
43	2100001501	海綿 Seal (SH1501)-----	1
44	8MN08500800A	螺絲Screw(CT10461M8-1.25*8)-----	2

8. MT4000 / MT4500 / MT4600 進給變換機構 Feed Mechanism

Subclass / Remark	Date
	2026/03/05

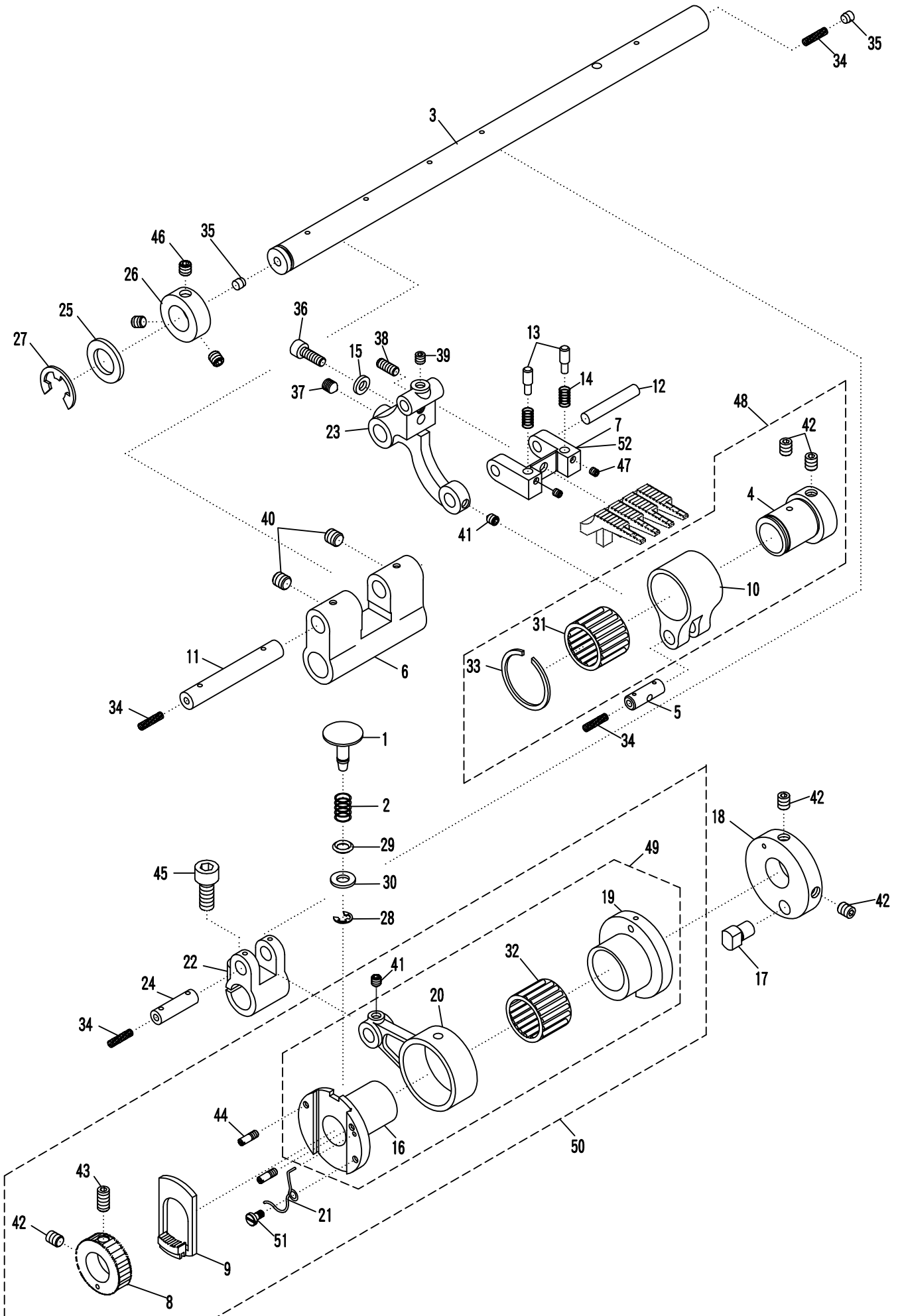

8. MT4000 / MT4500 / MT4600 進給變換機構 Feed Mechanism

Subclass / Remark	Date
	2026/03/05

序號 Ref.No.	物料編號 Parts No.	名稱 Description	單位用量 Amt. Req.
1	23100008011	止動銷 Stopper Pin -----	1
2	2310000802	彈簧 Spring -----	1
3	23100008031	軸 Shaft -----	1
4	2310000804	偏心輪 Eccentric -----	1
5	2310000805	連結銷 Link Pin -----	1
6	2310000806	曲柄 Lever -----	1
**7	2330000807	狗齒台 Feed Dog Holder -----	1
8	2310000808	離合齒輪 Regulating Gear -----	1
9	2310000809	離合齒片 Regulating Plate -----	1
10	2310000810	連桿 Link -----	1
11	2310000811	連結銷 Link Pin -----	1
12	2310000812	軸 Shaft -----	1
13	2310000813	銷 Pin -----	2
14	2310000814	彈簧 Spring -----	2
15	2310000815	墊圈 Washer -----	1
16	2310000816	變距偏心輪 Eccentric -----	1
17	2310000817	變距銷 Pin -----	1
18	2310000818	變距銷座 Eccentric Collar -----	1
19	2310000819	進給偏心輪 Eccentric -----	1
20	2310000820	連桿 Link -----	1
21	23100008212	彈簧 Spring -----	1
22	2310000822	曲柄 Lever -----	1
23	2310000823	連桿 Link -----	1
24	2310000824	連結銷 Link Pin -----	1
25	2310000825	墊圈 Washer -----	1
26	2310000826	定位環 Collar -----	1
27	90ER100	E形扣環 E Ring (RP10108) -----	1
28	90ER040	E形扣環 E Ring (FT0225) -----	1
29	90OR050	O形油環 O Ring -----	1
30	2200001025	墊圈 Washer (CT1025)-----	1
31	90NB182217	滾針軸承 Needle Bearing -----	1
32	90NB252913	滾針軸承 Needle Bearing -----	1
33	2310000833	C形同心扣環 C Ring -----	1
34	66800	油線 Oil Wick -----	4
35	2310000835	孔塞 Plug -----	2
36	8MM04281207A	螺絲 Screw (CT0202 M4-0.7*12) -----	1
37	8MN05320600C	螺絲 Screw (CT350248 M5-0.8*6) -----	1
38	8MN04281000A	螺絲 Screw (CT0216 M4-0.7*10) -----	1
39	8MN04280400A	螺絲 Screw (CT0229 M4-0.7*4) -----	1
40	8MN06400600A	螺絲 Screw (CT0244 M6-1*6) -----	2
41	8MN04280500C	螺絲 Screw (FT1222 M4-0.7*5) -----	1
42	8MN05320600A	螺絲 Screw (MT0729 M5-0.8*6) -----	5
43	8MN05321000E	螺絲 Screw (MT0843 M5-0.8*10) -----	1
44	8MB03200403C	螺絲 Screw (MT0844 M3-0.5*4) -----	2
45	8MM06401510A	螺絲 Screw (MT0845 M6-1*15) -----	1
46	8MN05320500E	螺絲 Screw (CT0903 M5-0.8*5) -----	3
47	8MN03200300A	螺絲 Screw (CT0115 M3-0.5*3) -----	2
48	231A0000848	連桿組 Link Asm. -----	1
49	231A0000849	變距偏心輪組 Eccentric Asm. -----	1
50	231A0000850	離合齒輪組 Regulating Gear Asm. -----	1
51	8MB03200606B	螺絲 Screw (MT0851 M3-0.5*3) -----	1
*52	2310000807	狗齒台 Feed Dog Holder -----	1

* MT4000 / MT4500 用 For MT4000 / MT4500 Use

** MT4600 用 For MT4600 Use

9. MT4600 結線鉤驅動機構 Looper Mechanism

Subclass / Remark	Date
	2026/03/05

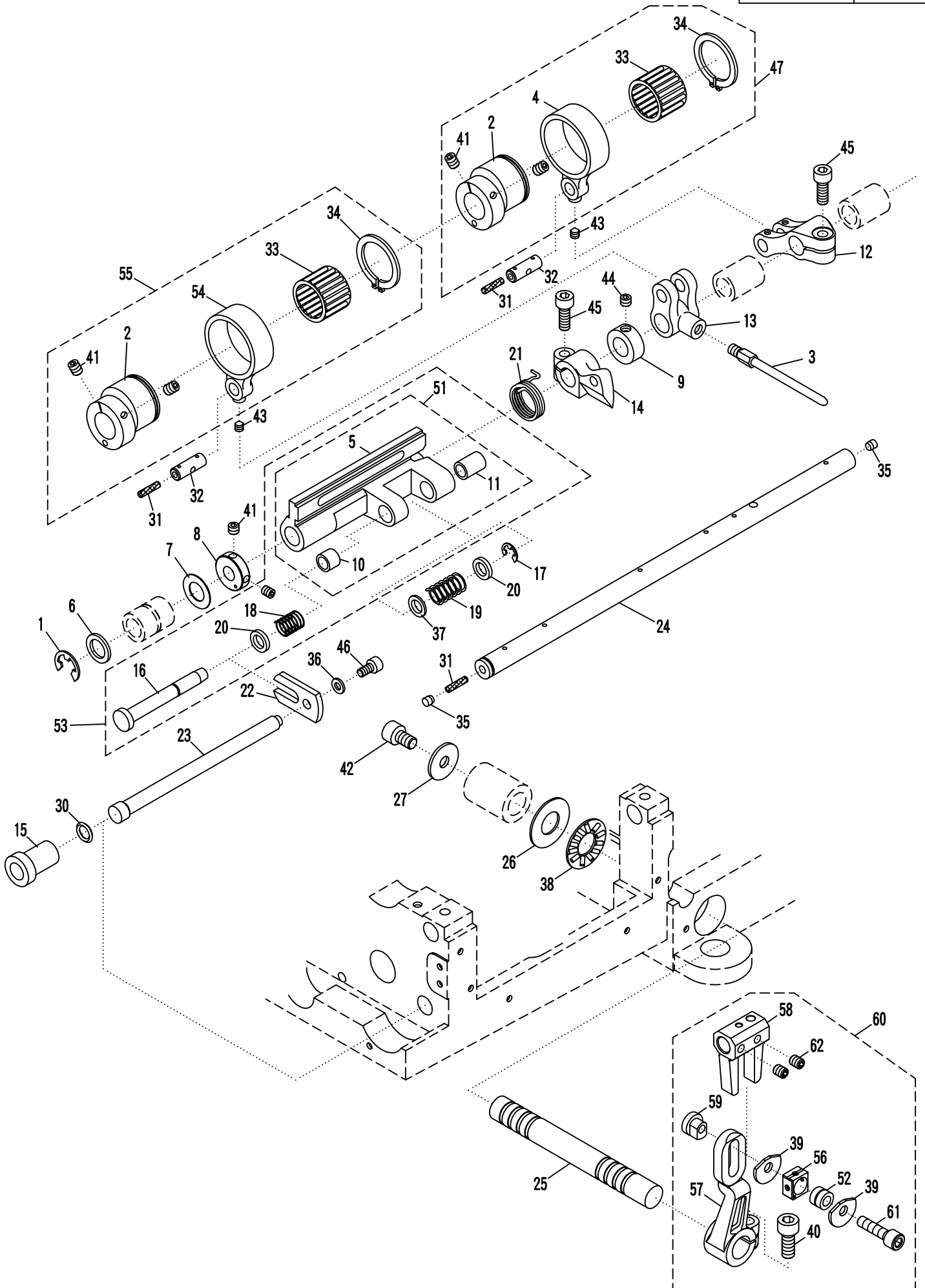

9. MT4600 結線鉤驅動機構 Looper Mechanism

Subclass / Remark	Date
	2026/03/05

序號 Ref.No.	物料編號 Parts No.	名稱 Description	單位用量 Amt. Req.
1	90ER080	E形扣環 E Ring (F090404)	1
2	231000902	偏心輪 Eccentric	2
3	231000903	撥線桿 Take-up Rod	1
4	231000904	連桿 Link	1
◎5	2310009051	承座 Bracket	1
6	2310009061	墊圈 Washer	1
7	231000907	墊圈 Washer	1
8	231000908	定位環 Collar	1
9	231000909	定位環 Collar	1
◎10	231000910	襯套 Clutch Tension Sleeve	1
◎11	231000911	襯套 Clutch Tension Sleeve	1
12	231000912	曲柄 Lever	1
13	231000913	曲柄 Lever	1
14	2310009141	驅動柄 Looper Rocker Stopper	1
15	231000915	栓 Stud	1
16	2310009161	軸 Shaft	1
17	90ER050	E形扣環 E Ring (SH0620)	1
18	231000918	彈簧 Spring	1
19	231000919	彈簧 Spring	1
20	231000920	墊圈 Washer	2
21	231000921	彈簧 Spring	1
22	231000922	隔板 Plate	1
23	231000923	軸 Shaft	1
24	2310009241	軸 Shaft	1
25	231000925	軸 Shaft	1
26	231000926	止推墊圈 Thrust Washer	1
27	231000927	墊圈 Washer	1
28	-----	-----	-
29	-----	-----	-
30	231000930	O形油環 O Ring	1
31	66800	油線 Oil Wick ϕ 3	3
32	231000805	連結銷 Link Pin	2
33	90NB252913	滾針軸承 Needle Bearing	2
34	90SCR250	C形扣環 C Ring	2
35	231000835	孔塞 Plug	2
36	90SW040	彈簧墊圈 Spring Washer (UTB0317)	1
37	240012039	墊圈 Washer	1
38	2200001044	滾針止推軸承 Needle Bearing (CT1044)	1
39	231000939	墊圈 Washer	2
40	8MM06401510A	螺絲 Screw (MT0845 M6-1*15)	1
41	8MN05320600A	螺絲 Screw (MT0729 M5-0.8*6)	6
42	8MM06401010A	螺絲 Screw (MT0419 M6-1*10)	1
43	8MN04280500C	螺絲 Screw (FT1222 M4-0.7*5)	2
44	8MN05320400A	螺絲 Screw (MT0944 M5-0.8*4)	2
45	8MM05321409A	螺絲 Screw (CT0632 M5-0.8*14)	2
46	8MM04280607A	螺絲 Screw (MT1134 M4-0.7*6)	1
47	231A0000947	偏心輪組 Eccentric Asm.	1
48	-----	-----	-
49	-----	-----	-
50	-----	-----	-
◎51	231A00009511	承座組 Bracket Asm.	1
52	231000952	襯套 Clutch Tension Sleeve	1
53	231A0000953	承座組 Bracket Asm.	1
54	231000954	連桿 Link	1
55	231A0000955	偏心輪組 Eccentric Asm.	1
56	231000956	滑塊 Slide Block	1
57	231000957	擺動臂 Spreader Arm	1
58	231000958	撥線軸座 Retainer Bar Holder	1
59	231000959	隔環 Spacer	1
60	231A0000960	撥線軸座組 Retainer Bar Holder Asm.	1
61	8MM05322009A	螺絲 Screw (TTS34-02-26 M5-0.8*20)	1
62	8MN05320500A	螺絲 Screw (EF0144 M5-0.8*5)	2

◎需整組購買 Must be sold in complete set

10. MT4000 / MT4500 / MT4600 壓腳與相關零件

Subclass / Remark	Date
	2026/03/05

Presser Foot Mechanism

序號 Ref.No.	物料編號 Parts No.	名稱 Description	單位用量 Amt. Req.
1	2310001001	螺椿 Stud -----	1
2	2310001002	螺帽 Nut -----	1
3	2310001003	彈簧 Spring -----	1
4	2310001004	連接塊 Connecting Block -----	1
5	2310001005	彈簧 Spring -----	1
6	2310001006	軸 Shaft -----	1
7	2310001007	滑道 Lower Movable Knife Guide -----	1
8	2310001008	揚昇臂 Lifter Arm -----	1
9	2310001009	曲柄 Lever -----	1
10	23100010101	曲柄 Lever -----	1
11	2310001011	吊桿 Lifter Connecting Plate -----	1
12	2310001012	墊圈 Washer -----	1
13	2310001013	螺椿 Stud -----	1
14	2310001014	拉桿 Lifter Connecting Plate -----	1
15	2310001015	吊臂 Left Upper Feed Roller Arm -----	1
16	23100010161	吊臂 Left Upper Feed Roller Arm -----	1
17	2310001017	銷 Pin -----	1
*18	2310001018	軸 Shaft -----	1
19	2310001019	彈簧 Spring -----	1
20	8SK56322110A	螺絲 Screw (MT1020 7/32"-32*21) -----	1
21	2310001021	連結銷 Connecting Pin -----	2
22	2310000908	定位環 Collar -----	1
23	2200000811	阻油片 Oil Separator (CT0811) -----	1
24	2100000323	墊圈 Washer (SH0323) -----	2
25	90ER040	E形扣環 E Ring (CT0209) -----	2
26	8SA56320410A	螺帽 Nut (F090512 7/32"-32*21) -----	1
27	8MC95301608E	螺絲 Screw (C08-08 M4.5-0.75*16) -----	2
28	8MN05320600A	螺絲 Screw (MT0729 M5-0.8*6) -----	2
29	8MM05321209A	螺絲 Screw (FT0524 M5-0.8*12) -----	1
30	8SC44400810G	螺絲 Screw (MT1030 11/64"-40*5) -----	2
31	8MM06401010A	螺絲 Screw (MT0419 M6-1*10) -----	2
32	8MM04281007A	螺絲 Screw (FT0203 M4-0.7*10) -----	1
33	2310001207	波形墊圈 Corrugated Ring -----	1
34	2310001034	護指擋片 Safety Plate Holder (MT4□01-MT4□04) -----	1
35	2310001035	護指擋片 Safety Plate Holder (MT4□06-MT4□25) -----	1
36	8MB85240605A	螺絲 Screw (CT1002 M3.5-0.6*6) -----	1
37	8MM04280807A	螺絲 Screw (M0124 M4-0.7*8) -----	2
38	231A0001038	壓力調整螺椿組 Spring Regulator Set -----	1

* 二件組壓腳底用 For bisector presser foot

11. MT4000 / MT4500 / MT4600 潤滑系統 Lubrication Mechanism

Subclass / Remark	Date
	2026/03/05

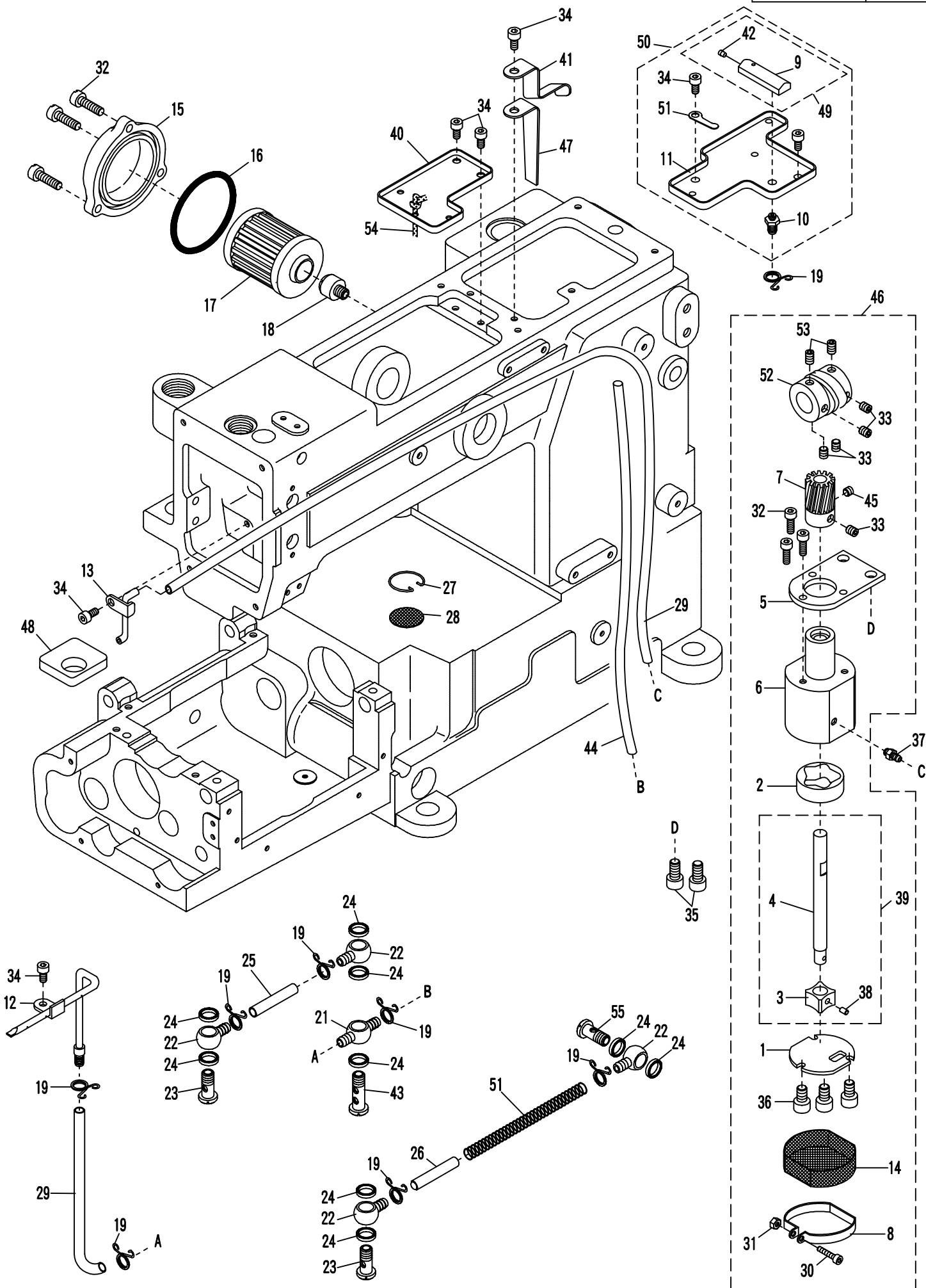

11. MT4000 / MT4500 / MT4600 潤滑系統 Lubrication Mechanism

Subclass / Remark	Date
	2026/03/05

序號 Ref.No.	物料編號 Parts No.	名稱 Description	單位用量 Amt. Req.
◎1	2310001101	蓋板 Lower Feed Roller Cover -----	1
◎2	23100011021	齒輪 Gear -----	1
◎3	23100011031	齒輪 Gear -----	1
◎4	23100011041	軸 Shaft -----	1
◎5	2310001105	泵座 Pump Seat -----	1
◎6	2310001106	泵 Pump -----	1
◎7	2310001107	蝸母 Worm Gear -----	1
8	2310001108	夾簧 Latch Spring -----	1
◎9	2310001109	導油歧路 Lubricant Guiding Block -----	1
10	2310001110	油嘴 Nozzle -----	1
11	2310001111	承油盤 Oil Receiver -----	1
12	2310001112	油管 Oil Tube -----	1
13	2310001113	油管 Oil Tube -----	1
14	2310001114	油網 Oil Mesh -----	1
15	2200001311	封蓋 Oil Filter Cover -----	1
16	2200001313	O形油環 O Ring (CT1313) -----	1
17	2100001521	過濾器 Oil Filter (SH1521) -----	1
18	2200001315	過濾器接頭 Oil Filter Joint (CT1315) -----	1
19	2100001536	夾簧 Latch Spring (SH1536) -----	8
20	-----	-----	-
21	2200001327	油管接頭 Oil Tube Joint (CT1327) -----	1
22	2100001535	油管接頭 Oil Tube Joint (SH1535) -----	4
23	2100001533	螺椿 Stud (SH1533) -----	2
24	2100001534	墊圈 Washer (SH1534) -----	9
25	2200001328	油管 Oil Tube (CT1328) -----	1
26	2200001332	油管 Oil Tube (CT1332) -----	1
27	2200001316	扣簧 Filter Screen Clamp (CT1316) -----	1
28	2200001317	網板 Filter Screen (CT1317) -----	1
29	66790	油管 Oil Tube (ϕ 3* ϕ 5) -----	2
30	8MM03201606A	螺絲 Screw (MT11-30 M3-0.5*16) -----	1
31	8MA03200306A	螺帽 Nut (FTB0111 M3-0.5*3) -----	1
◎32	8MM04281207A	螺絲 Screw (CT0202 M4-0.7*12) -----	6
◎33	8MN05320600A	螺絲 Screw (MT7-29 M5-0.8*6) -----	5
34	8MM04280607A	螺絲 Screw (MT1134 M4-0.7*6) -----	7
◎35	8MM06401210A	螺絲 Screw (FT1103 M6-1*12) -----	2
◎36	8MM03200606A	螺絲 Screw (CT130406 M3-0.5*6) -----	3
◎37	2100001505	油嘴 Oil Tube Joint (SH1505) -----	1
◎38	90SP0310	彈簧銷 Spring Pin (SH0508) -----	1
◎39	231A0001139	齒輪組 Gear Asm. -----	1
40	2310001140	承油盤 Oil Receiver -----	1
41	2310001141	油管支持臂 Oil Tube Holder -----	1
◎42	2200000550	孔塞 Plug (CT0550) -----	1
43	2200001338	螺椿 Stud (CT1338) -----	1
44	66792	油管 Oil Tube (ϕ 4.1* ϕ 5.7) -----	1
◎45	8MN05320400A	螺絲 Screw (MT0944 M5-0.8*4) -----	1
46	231A0001146	泵組 Pump Asm. -----	1
47	2310001147	油管支持臂 Oil Tube Holder -----	1
48	2310001148	羊毛氈 Felt -----	1
49	231A0001149	導油歧路組 Lubricant Guiding Block Asm. -----	1
50	231A0001150	承油盤組 Oil Receiver Asm. -----	1
51	2270001377	彈簧 Spring -----	1
◎52	2310000713	蝸桿 Worm -----	1
◎53	8MN05320800C	螺絲 Screw (MT1153 M5-0.8*8) -----	2
54	66800	油線 Oil Wick -----	1
55	2120001220	迴路螺絲 Screw (UH1220) -----	1

◎ 需整組購買 Must be sold in complete set

12. MT4000 / MT4500 / MT4600 後引式拖輪機構 Rear Puller Mechanism

Subclass / Remark	Date
	2026/03/05

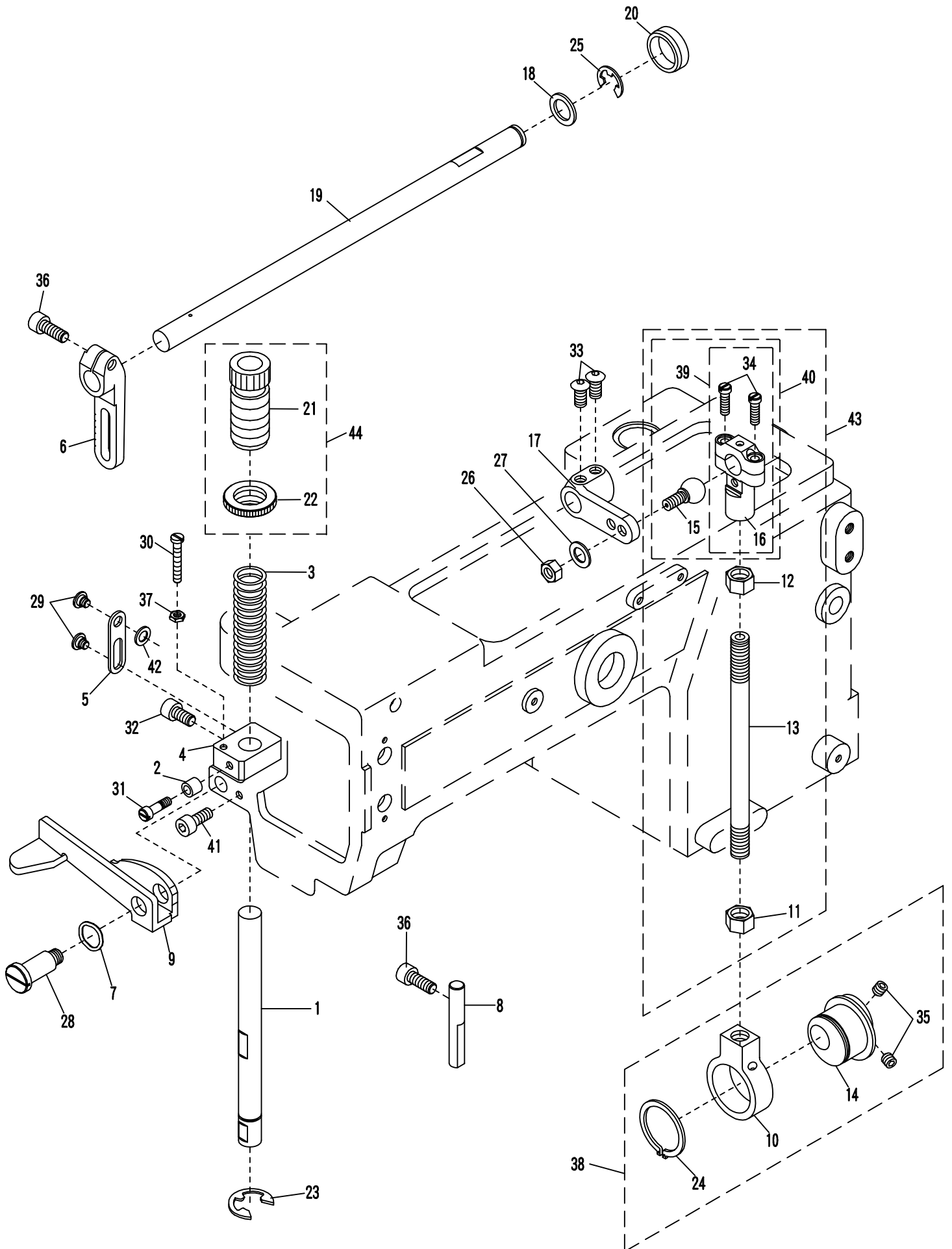

12. MT4000 / MT4500 / MT4600 後引式拖輪機構

Subclass / Remark	Date
	2026/03/05

Rear Puller Mechanism

序號 Ref.No.	物料編號 Parts No.	名稱 Description	單位用量 Amt. Req.
1	2310001201	軸 Shaft -----	1
2	2310001202	定位環 Collar -----	1
3	2310001203	彈簧 Sping -----	1
4	2310001204	彈簧座 Spring Set -----	1
5	2310001205	吊桿 Lifter Connecting Plate -----	1
6	23100012061	拉臂 Upper Feed Roller Arm -----	1
7	2310001207	波形墊圈 Corrugated Washer -----	1
8	4RP0010210	軸 Shaft -----	1
9	2310001209	揚昇手臂 Lifter Arm -----	1
◎10	23100012101	接頭 Joint -----	1
11	2310000718	螺帽 Nut -----	1
12	2310000719	螺帽 Nut -----	1
13	23100012131	螺椿 Stud -----	1
◎14	2310001214	偏心輪 Eccentric -----	1
◎15	2310001215	球狀接頭 Ball Stud -----	1
◎16	2310001216	連桿 Link -----	1
17	23100012171	連桿 Link -----	1
18	2310001218	墊圈 Washer -----	1
19	2310001219	軸 Shaft -----	1
20	22000002451	孔塞 Plug (CT0245) -----	1
21	2310001221	調壓螺椿 Spring Regulator -----	1
22	2310001222	螺帽 Nut -----	1
23	90ER100	E形扣環 Ring (RP10108) -----	1
◎24	90SCR280	C形扣環 C Ring -----	1
25	90ER090	E形扣環 E Ring (SH0658) -----	1
26	8MA06400510A	螺帽 Nut (CT0533 M6-1*5) -----	1
27	2200000910	墊圈 Washer (CT0910) -----	1
28	8MB08502816G	螺椿 Stud (MT1228 M8-1.25*7) -----	1
29	8SC44400810G	螺絲 Screw (MT1030 11/64"-40*5) -----	2
30	8SB44403006K	螺絲 Screw (MT1230 11/64"-40*30) -----	1
31	8SB44401507G	螺絲 Screw (MT1231 11/64"-40*7) -----	1
32	8MM06401410A	螺絲 Screw (UH0808 M6-1*14) -----	1
33	8MP06400811A	螺絲 Screw (FTC1-01-23 M6-1*8) -----	2
◎34	8MB95301507K	螺絲 Screw (MT0726 M4.5-0.75*15) -----	2
◎35	8MN06400600A	螺絲 Screw (CT0244 M6-1*6) -----	2
36	8MM06401610A	螺絲 Screw (CT0625 M6-1*16) -----	2
37	8SA44400407A	螺帽 Nut (SH0111 11/64"-40*4) -----	1
38	231A0001238	偏心輪組 Eccentric Asm. -----	1
◎39	231A0001239	連桿組 Link Asm. -----	1
40	231A0001240	連桿組 Link Asm. -----	1
41	8MM04281007A	螺絲 Screw (FT0203 M4-0.7*10) -----	1
42	2310001242	減震橡膠 Rubber Cushion -----	1
43	231A0001243	連桿組 Link Asm. -----	1
44	231A0001244	調壓螺椿組 Spring Regulator Asm. -----	1

◎ 需整組購買 Must be sold in complete set

13. MT4001-MT4004 / MT4504 / MT4604 後引式拖輪機構

Rear Puller Mechanism

Subclass / Remark	Date
	2026/03/05

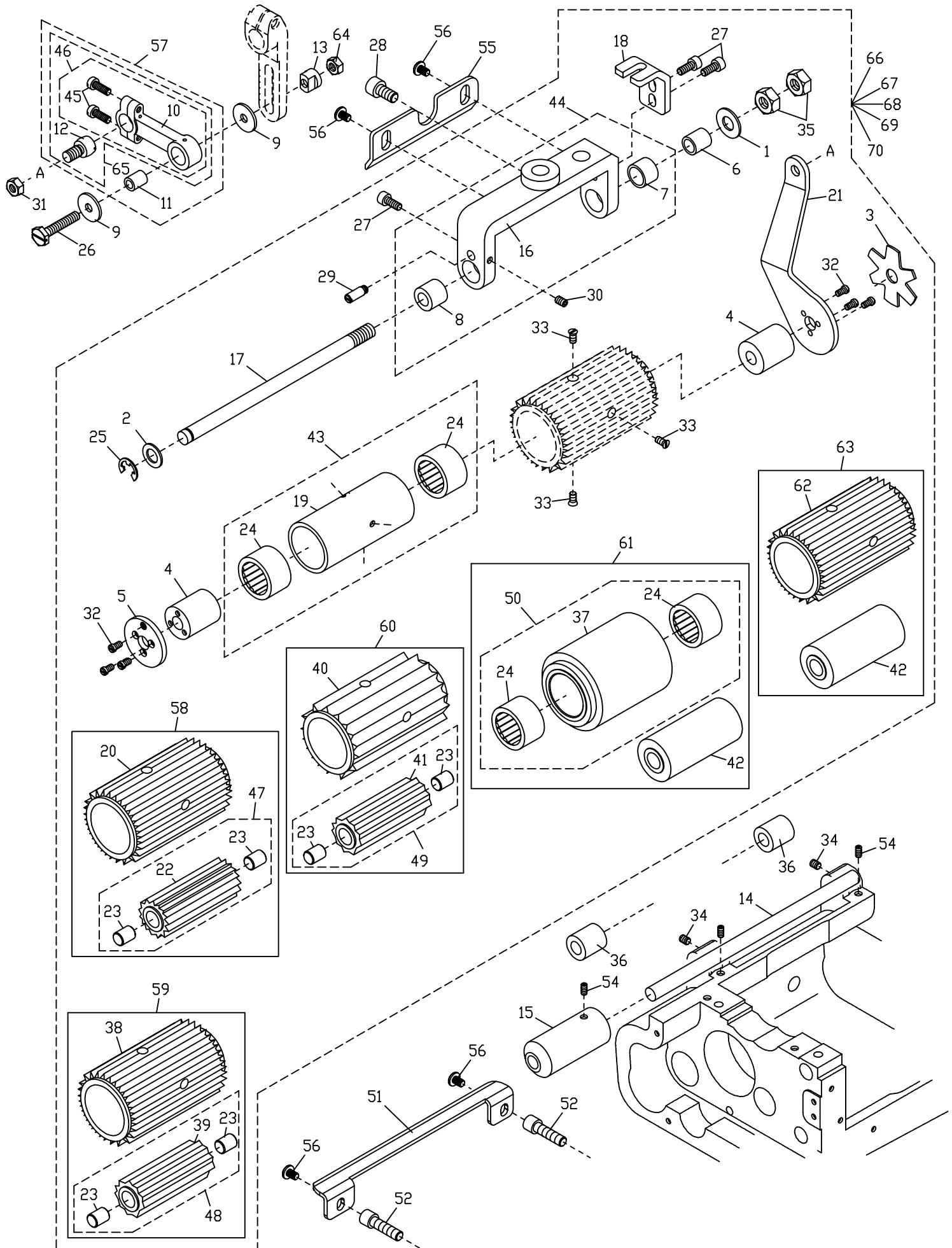

13. MT4001-MT4004 / MT4504 / MT4604 後引式拖輪機構

Subclass / Remark	Date
	2026/03/05

Rear Puller Mechanism

序號 Ref.No.	物料編號 Parts No.	名稱 Description	單位用量 Amt. Req.
1	2310001301	墊圈 Washer -----	1
2	2310001302	墊圈 Washer -----	1
3	2310001303	星形壓環 Clutch Tension Spring -----	1
4	23100013042	離合器 Clutch -----	2
5	2310001305	封蓋 Cover -----	1
6	2310001306	襯套 Clutch Tension Sleeve -----	1
◎7	2310001307	軸襯 Bushing -----	1
◎8	2310001308	軸襯 Bushing -----	1
9	2310001309	墊圈 Washer -----	2
◎10	2310001310	連桿 Link -----	1
11	2310001311	襯套 Clutch Tension Sleeve -----	1
◎12	2310001312	球狀接頭 Ball Joint -----	1
13	2310001313	隔環 Spacer -----	1
14	2310001314	軸 Shaft -----	1
15	23100013151	套筒 Clutch Sleeve -----	1
◎16	2310001316	主動輪軸 Bracket -----	1
17	2310001317	軸 Shaft -----	1
18	23100013181	導軌 Yoke Guide -----	1
◎19	23100013191	套筒 Clutch Sleeve -----	1
◎20	2310001320	主動輪 Upper Feed Rollar (28 齒) -----	1
21	2310001321	拉柄 Clutch Driving Lever -----	1
◎22	2310001322	從動輪 Lower Feed Roller (15齒) -----	1
◎23	2310001323	軸襯 Bushing -----	2
◎24	90NB2026161	單向滾針軸承 Needle Bearing -----	2
25	90ER070	E形扣環 E Ring -----	1
26	8MK05322710A	螺絲 Screw (MT1326 M5-0.8*27) -----	1
27	8MM04281007A	螺絲 Screw (FT0203 M4-0.7*10) -----	3
28	8MM06401010A	螺絲 Screw (MT0419 M6-1*10) -----	1
29	8SB44400305N	螺絲 Screw (MT1329 11/64"-40*3) -----	1
30	8MN04280600A	螺絲 Screw (CT1223 M4-0.7*6) -----	1
31	8SA64400409B	螺帽 Nut (RP0319 1/4"-40*4) -----	1
32	8SB32440604A	螺絲 Screw (MT1332 1/8"-44*6) -----	6
33	8SF36400606A	螺絲 Screw (RP10217 9/64"-40*8) -----	3
34	8MN04280500A	螺絲 Screw (MT1334 M4-0.7*5) -----	2
35	8MA08500613A	螺帽 Nut (RP10208 M8-1.25*6) -----	2
36	2310001336	隔環 Spacer -----	2
◎37	2310001337	主動輪 Upper Feed Roller (0 齒) -----	1
38	2310001338	主動輪 Upper Feed Rollar (22 齒) -----	1
◎39	2310001339	從動輪 Lower Feed Roller (12 齒) -----	1
40	2310001340	主動輪 Upper Feed Rollar (18 齒) -----	1
◎41	2310001341	從動輪 Lower Feed Roller (10 齒) -----	1
42	2310001342	從動輪 Lower Feed Roller (0 齒) -----	1
43	231A0001343	套筒組 Clutch Sleeve Asm. -----	1
44	231A0001344	主動輪軸組 Upper Feed Roller Shaft Asm. -----	1
◎45	8MB85241006K	螺絲 Screw (CT0621 M3.5-0.6*10) -----	2
◎46	231A0001346	連桿組 Link Asm. -----	1
47	231A0001347	從動輪組 Lower Feed Roller Asm. (15 齒) -----	1
48	231A0001348	從動輪組 Lower Feed Roller Asm. (12 齒) -----	1
49	231A0001349	從動輪組 Lower Feed Roller Asm. (10 齒) -----	1
50	231A0001350	從動輪組 Lower Feed Roller Asm. (0齒) -----	1
51	23100013511	護蓋 Cover -----	1
52	2310001352	螺樁 Stud -----	2
53	-----	-----	-
54	8MN05320600A	螺絲 Screw (MT7-29 M5-0.8*6) -----	3
55	2310001355	護蓋 Cover -----	1
56	8MB04280608A	螺絲 Screw (UTB0130 M4-0.7*6) -----	4
57	231A0001357	連桿組 Link Asm. -----	1
58	231A0001358	拖輪組 Puller Asm. (P) -----	1
●59	231A0001359	拖輪組 Puller Asm. (P2) -----	1
●60	231A0001360	拖輪組 Puller Asm. (P1) -----	1
●61	231A0001361	拖輪組 Puller Asm. (P0) -----	1
62	2310001362	主動輪 Upper Feed Rollar (59 齒) -----	1
●63	231A0001363	拖輪組 Puller Asm. (P3) -----	1
64	8MA05320408A	螺帽 Nut (CT1028 M5-0.8*4) -----	1
65	231A0001365	連桿組 Link Asm. -----	1
66	231A0001366	拖輪組 Puller Asm.(28齒) -----	1
67	231A0001367	拖輪組 Puller Asm.(22齒) -----	1
68	231A0001368	拖輪組 Puller Asm.(18齒) -----	1
69	231A0001369	拖輪組 Puller Asm.(0齒) -----	1
70	231A0001370	拖輪組 Puller Asm.(59齒) -----	1

◎ 需整組購買 Must be sold in complete set

● 特註品 Custom-made Item

14. MT4006-MT4012 / MT4506-MT4525 / MT4606-MT4625

後引式拖輪機構 Rear Puller Mechanism

Subclass / Remark	Date
	2026/03/05

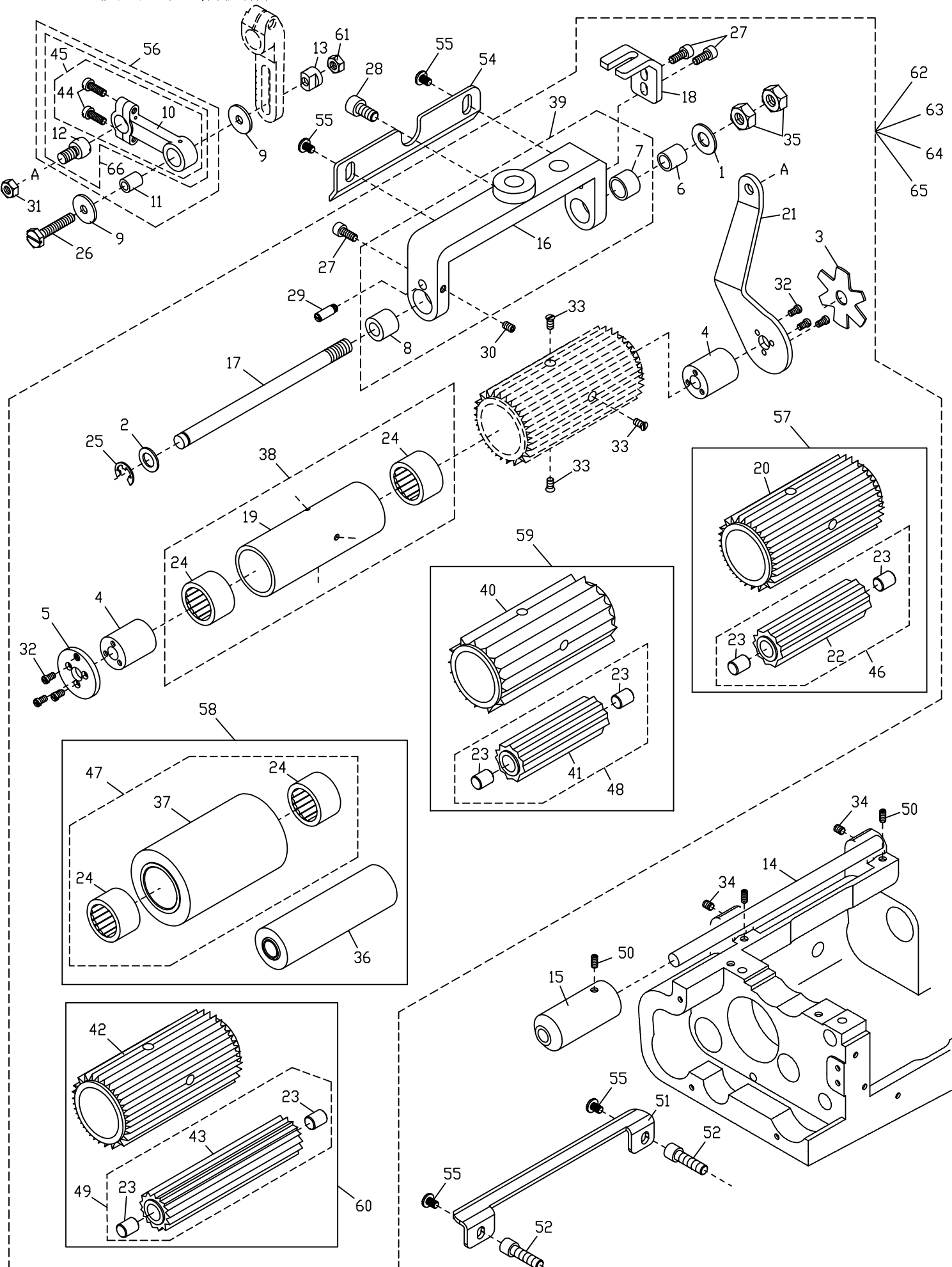

14. MT4006-MT4012 / MT4506-MT4525 / MT4606-MT4625

Subclass / Remark	Date
	2026/03/05

後引式拖輪機構 Rear Puller Mechanism

序號 Ref.No.	物料編號 Parts No.	名稱 Description	單位用量 Amt. Req.
1	2310001301	墊圈 Washer -----	1
2	2310001302	墊圈 Washer -----	1
3	2310001303	星形壓環 Clutch Tension Spring -----	1
4	23100013042	離合器 Clutch -----	2
5	2310001305	封蓋 Cover -----	1
6	2310001306	襯套 Clutch Tension Sleeve -----	1
◎7	2310001307	軸襯 Bushing -----	1
◎8	2310001308	軸襯 Bushing -----	1
9	2310001309	墊圈 Washer -----	2
◎10	2310001310	連桿 Link -----	1
11	2310001311	襯套 Clutch Tension Sleeve -----	1
◎12	2310001312	球狀接頭 Ball Joint -----	1
13	2310001313	隔環 Spacer -----	1
14	2310001314	軸 Shaft -----	1
15	23100013151	套筒 Clutch Sleeve -----	1
◎16	2310001416	主動輪軸 Bracket -----	1
17	2310001417	軸 Shaft -----	1
18	23100014181	導軌 Yoke Guide -----	1
◎19	23100014191	套筒 Clutch Sleeve -----	1
◎20	2310001420	主動輪 Upper Feed Rollar (22齒) -----	1
21	2310001421	拉柄 Clutch Driving Lever -----	1
◎22	2310001422	從動輪 Lower Feed Roller (12齒) -----	1
◎23	2310001323	軸襯 Bushing -----	2
◎24	90NB202626	單向滾針軸承 Needle Bearing -----	2
25	90ER070	E形扣環 E Ring -----	1
26	8MK05322710A	螺絲 Screw (MT1326 M5-0.7*27) -----	1
27	8MM04281007A	螺絲 Screw (FT0203 M4-0.7*10) -----	3
28	8MM06401010A	螺絲 Screw (MT0419 M6-1*10) -----	1
29	8SB44400305N	螺絲 Screw (MT1329 11/64"-40*3) -----	1
30	8MN04280600A	螺絲 Screw (CT1223 M4-0.7*6) -----	1
31	8SA64400409B	螺帽 Nut (RP0319 1/4"-40*4) -----	1
32	8SB32440604A	螺絲 Screw (MT1332 1/8"-44*6) -----	6
33	8SF36400606A	螺絲 Screw (RP10217 9/64"-40*8) -----	3
34	8MN04280500A	螺絲 Screw (MT1334 M4-0.7*5) -----	2
35	8MA08500613A	螺帽 Nut (RP10208 M8-1.25*6) -----	2
36	2310001436	從動輪 Lower Feed Roller (0 齒) -----	1
◎37	2310001437	主動輪 Lower Feed Roller (0 齒) -----	1
38	231A0001438	套筒組 Clutch Sleeve Asm. -----	1
39	231A0001439	主動輪軸組 Upper Feed Roller Shaft Asm. -----	1
40	2310001440	主動輪 Upper Feed Roller (18齒) -----	1
◎41	2310001441	從動輪 Lower Feed Roller (10 齒) -----	1
42	2310001442	主動輪 Upper Feed Roller (28齒) -----	1
◎43	2310001443	從動輪 Lower Feed Roller (15齒) -----	1
◎44	8MB85241006K	螺絲 Screw (CT0621 M3.5-0.6*10) -----	2
◎45	231A0001346	連桿組 Link Asm. -----	1
46	231A0001446	從動輪組 Lower Feed Roller Asm. (12 齒) -----	1
47	231A0001447	從動輪組 Lower Feed Roller Asm. (0 齒) -----	1
48	231A0001448	從動輪組 Lower Feed Roller Asm. (10 齒) -----	1
49	231A0001449	從動輪組 Lower Feed Roller Asm. (15 齒) -----	1
50	8MN05320600A	螺絲 Screw (MT7-29 M5-0.8*6) -----	3
51	23100013511	護蓋 Cover -----	1
52	2310001352	螺樁 Stud -----	2
53	-----	-----	-
54	2310001454	護蓋 Cover -----	1
55	8MB04280608A	螺絲 Screw (UTB0130 M4-0.7*6) -----	4
56	231A0001357	連桿組 Link Asm. -----	1
●57	231A0001457	拖輪組 Puller Asm. (P2) -----	1
●58	231A0001458	拖輪組 Puller Asm. (P0) -----	1
●59	231A0001459	拖輪組 Puller Asm. (P1) -----	1
60	231A0001460	拖輪組 Puller Asm. (P) -----	1
61	8MA05320408A	螺帽 Nut (CT1028 M5-0.8*4) -----	1
62	231A0001462	拖輪組 Puller Asm. (28齒) -----	1
63	231A0001463	拖輪組 Puller Asm. (18齒) -----	1
64	231A0001464	拖輪組 Puller Asm. (22齒) -----	1
65	231A0001465	拖輪組 Puller Asm. (0 齒) -----	1
66	231A0001365	連桿組 Link Asm. -----	1

◎需整組購買 Must be sold in complete set

●特註品 Custom-made Item

15. 667091 線架 MT4501 / MT4601 用 Thread Stand Mechanism

Subclass / Remark	Date
	2026/03/05

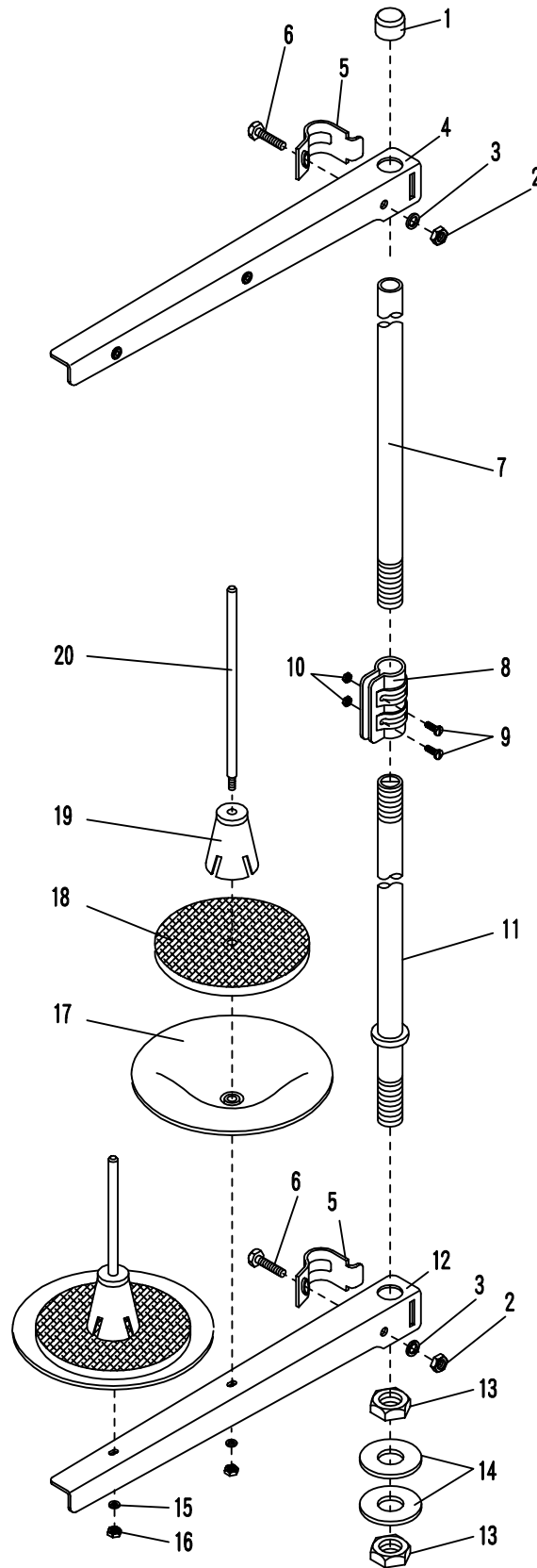

15. 667091 線架 MT4501 / MT4601 用 Thread Stand Mechanism

Subclass / Remark	Date
	2026/03/05

序號 Ref.No.	物料編號 Parts No.	名稱 Description	單位用量 Amt. Req.
◎1	6670919	孔塞 Cap -----	1
◎2	6670526	螺帽 Nut -----	2
◎3	6670525	彈簧墊圈 Spring Washer -----	2
◎4	6670918	導線臂 Thread Arm -----	1
◎5	667097	夾板 Clamp -----	2
◎6	667098	螺絲 Screw -----	2
◎7	6670917	上柱 Upper Thread Stand Rod -----	1
◎8	6670914	夾板 Clamp -----	1
◎9	6670915	螺絲 Screw -----	2
◎10	6670916	螺帽 Nut -----	2
◎11	6670913	下柱 Lower Thread Stand Rod -----	1
◎12	667092	線盤座 Spool Set Bracket -----	1
◎13	6670912	螺帽 Nut -----	2
◎14	6670911	墊圈 Washer -----	2
◎15	667099	彈簧墊圈 Spring Washer -----	2
◎16	6670910	螺帽 Nut -----	2
◎17	667093	線盤 Spool Set -----	2
◎18	667094	緩衝墊 Seat -----	2
◎19	667095	線盤軸 Spool Pin -----	2
◎20	667096	定心錐 Spool Retaining Fig -----	2

◎需整組購買 Must be sold in complete set

15-1. 66711-1 線架 MT4504 / MT4604 用

Thread Stand Mechanism

Subclass / Remark	Date
	2026/03/05

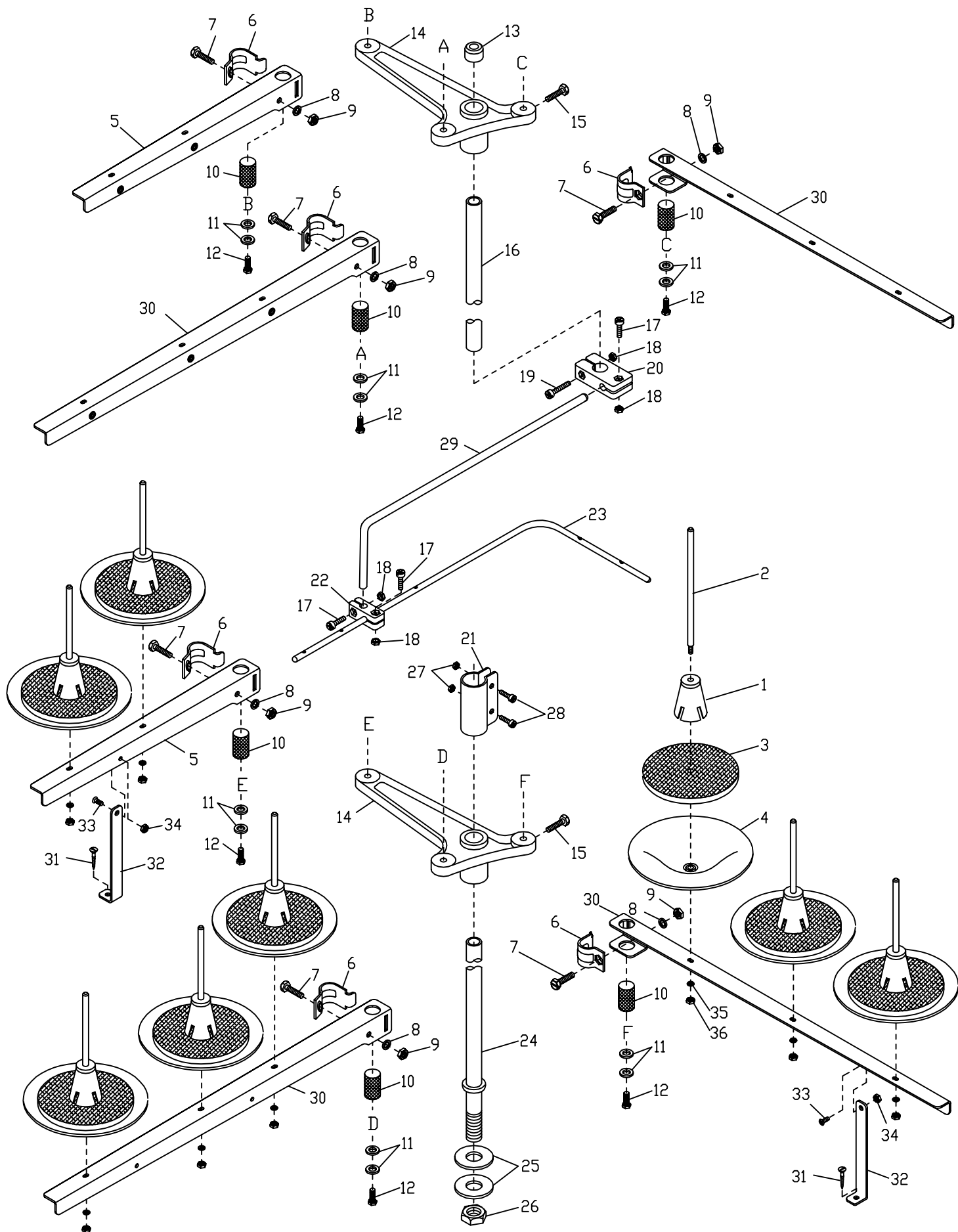

15-1. 66711-1 線架 MT4504 / MT4604 用

Subclass / Remark	Date
	2026/03/05

Thread Stand Mechanism

序號 Ref.No.	物料編號 Parts No.	名稱 Description	單位用量 Amt .Req.
◎1	667101	定心錐 Spool Retaining Fig (67101)-----	8
◎2	667102	線盤軸 Spool Pin (67102)-----	8
◎3	667103	緩衝墊 Seat (67103)-----	8
◎4	667104	線盤 Spool Set (67104)-----	8
◎5	667105	線盤座 Spool Set Bracket (67105)-----	2
◎6	667106	夾板 Clamp (67106)-----	6
◎7	667107	螺絲 Screw (67107)-----	6
◎8	667108	彈簧墊圈 Spring Washer (67108)-----	6
◎9	667109	螺帽 Nut (67109)-----	6
◎10	6671010	支架 Knife Holder Bracket (67010)-----	6
◎11	6671011	墊圈 Washer (671011)-----	12
◎12	6671012	螺絲 Screw (671012)-----	6
◎13	6671013	柱帽 Rod Cup (671013)-----	1
◎14	6671014	軸 Shaft (671014)-----	2
◎15	6671015	螺絲 Screw (671015)-----	2
◎16	6671016	上柱 Upper Thread Stand Rod (671016)-----	1
◎17	6671017	螺絲 Screw (671017)-----	3
◎18	6671018	螺帽 Nut (671018)-----	4
◎19	6671019	螺絲 Screw (671019)-----	1
◎20	6671020	接頭 Bracket (671020)-----	1
◎21	6671021	接頭 Bracket(671021)-----	1
◎22	6671022	接頭 Joint (671022)-----	1
◎23	6671023	導線桿 Thread Guide (671023)-----	1
◎24	6671024	下柱 Lower Thread Stand Rod (671024)-----	1
◎25	6671025	墊圈 Washer (671025)-----	2
◎26	6671026	螺帽 Nut (671026)-----	1
◎27	6671027	螺帽 Nut (671027)-----	2
◎28	6671028	螺絲 Screw (671028)-----	2
◎29	6671029	旋臂 Arm (671029)-----	1
◎30	6671030	線盤座 Spool Set Bracket (671030)-----	4
◎31	6671031	木螺絲 Wood Screw (671031)-----	2
◎32	6671032	撐桿 Support Rod (671032)-----	2
◎33	6671033	螺絲 Screw (671033)-----	2
◎34	6671034	螺帽 Nut (671034)-----	2
◎35	6671035	彈簧墊圈 Spring Washer (671035)-----	8
◎36	6671036	螺帽 Nut (671036)-----	8

◎需整組購買 Must be sold in complete set

16. 66711-5 & 66711-6 & 66711-7 線架 Thread Stand Mechanism MT4506-MT4525 / MT4606-MT4625 用

Subclass / Remark	Date
	2026/03/05

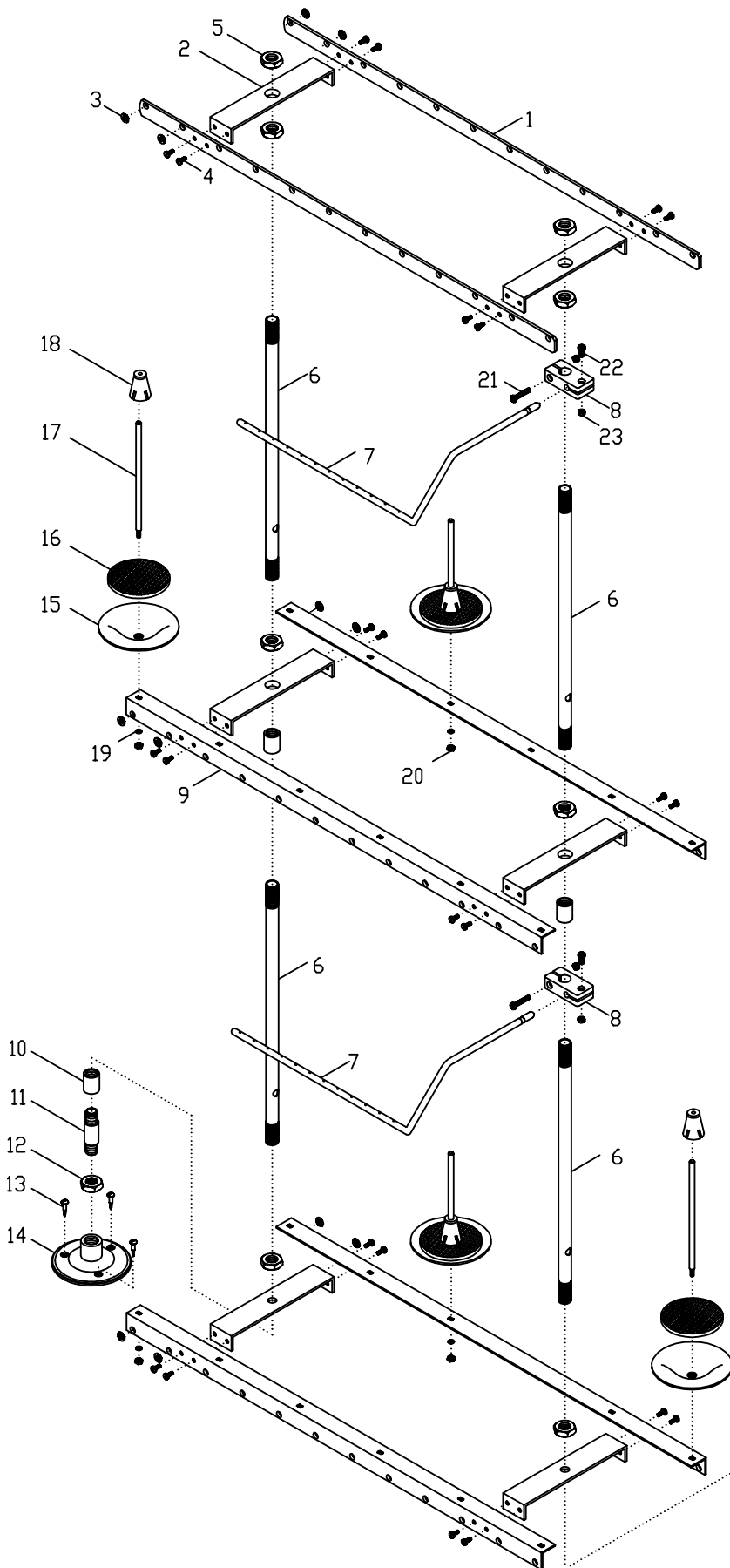

零件用量列表 Amt. Req.

Model 線架機型 組編號 序號 Ref. No.	MT4□06	MT4□09	MT4□12 MT4□25
	66711-5	66711-6	66711-7
2	4	6	6
3	48	72	72
4	16	24	24
5	6	8	8
6	2	4	4
7	1	2	2
8	1	2	2
9	2	4	4
10	2	4	4
15	12	18	24
16	12	18	24
17	12	18	24
18	12	18	24
19	12	18	24
20	12	18	24
21	1	2	2
22	1	2	2
23	2	4	4

16. 66711-5 & 66711-6 & 66711-7 線架 Thread Stand Mechanism

Subclass / Remark	Date
	2026/03/05

MT4506-4525 / MT4606-MT4625 用

序號 Ref.No.	物料編號 Parts No.	名稱 Description	單位用量 Amt. Req.
◎1	66711501	導線桿 Thread Guide -----	2
◎2	66711502	支架 Holder -----	-
◎3	66711503	導線 Thread Guide -----	-
◎4	66711504	螺絲 Screw -----	-
◎5	66711505	螺帽 Nut -----	-
◎6	66711506	柱 Thread Stand Rod -----	-
◎7	66711507	旋臂 Arm -----	-
◎8	66711508	接頭 Joint -----	-
◎9	66711509	線盤座 Spool Set Bracket -----	-
◎10	66711510	軸襯 Bushing -----	-
◎11	66711511	螺椿 Stud -----	2
◎12	66711512	螺帽 Nut -----	2
◎13	66711513	螺絲 Screw -----	6
◎14	66711514	基座 Base -----	2
◎15	66711515	線盤 Spool Set (See Left Page) -----	-
◎16	66711516	緩衝墊 Seat (See Left Page) -----	-
◎17	66711517	線盤軸 Spool Pin (See Left Page) -----	-
◎18	66711518	線盤軸 Spool Pin (See Left Page) -----	-
◎19	66711519	彈簧墊圈 Spring Washer -----	-
◎20	66711520	螺帽 Nut -----	-
◎21	66711521	螺絲 Screw -----	-
◎22	66711522	螺絲 Screw -----	-
◎23	66711523	螺帽 Nut -----	-

◎需整組購買 Must be sold in complete set

17. MT4609-MT4625 鬆線機構 Tension Stand Mechanism

Subclass / Remark	Date
	2026/03/05

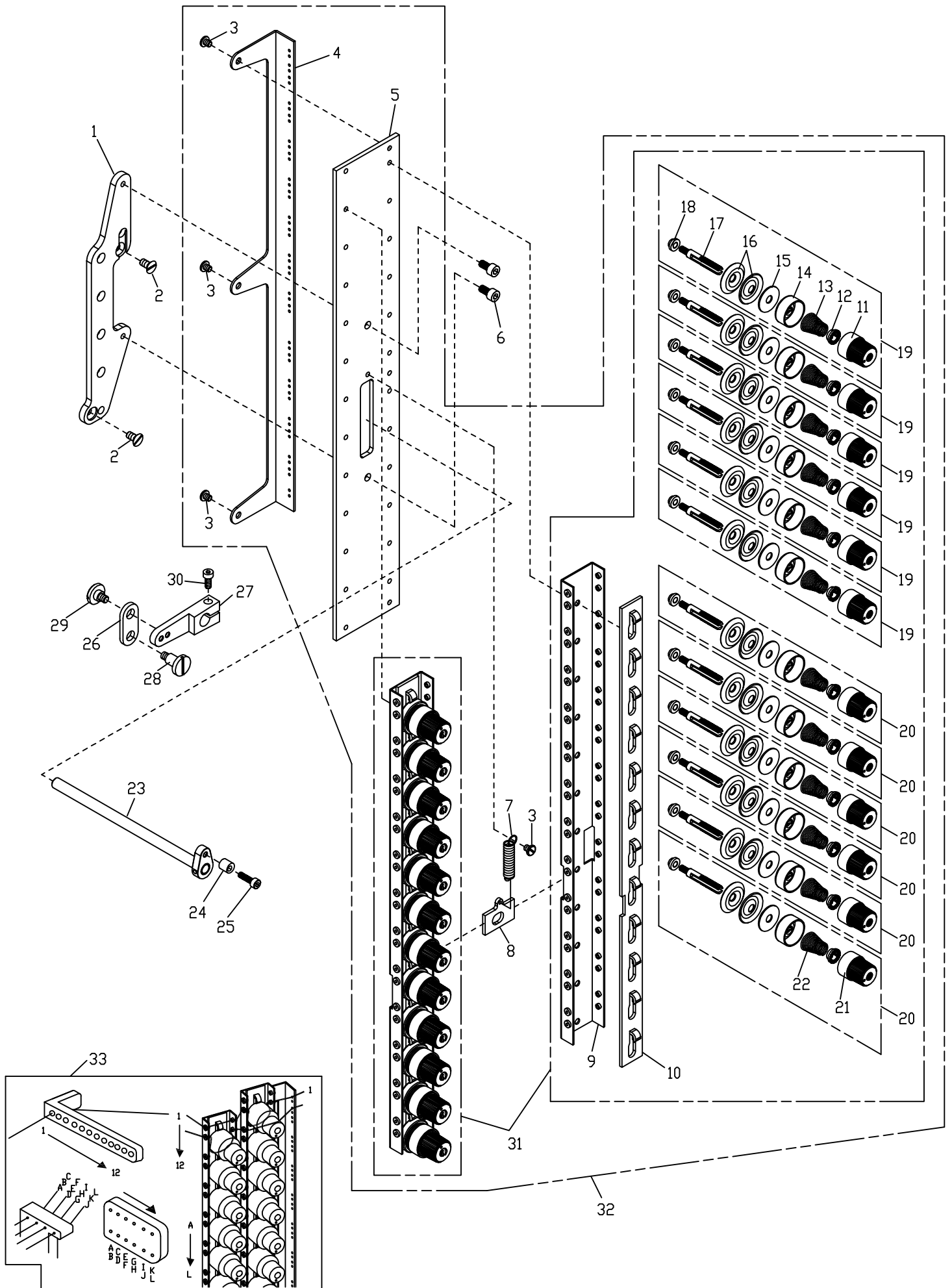

17. MT4609-MT4625 鬆線機構 Tension Stand Mechanism

Subclass / Remark	Date
	2026/03/05

序號 Ref.No.	物料編號 Parts No.	名稱 Description	單位用量 Amt. Req.
1	2330001701	鬆線座 Tension Post Support -----	1
2	8ME05321010A	螺絲 Screw (FTC1 0116 M5-0.8*10) -----	2
3	2330001703	螺絲 Screw (11/64"-40*5) -----	4
4	2330001704	導線 Thread Guide -----	1
5	2330001705	鬆線座 Tension Post Support -----	1
6	8MM05321009A	螺絲 Screw (C0626 M5-0.8*10) -----	2
7	2330001707	彈簧 Spring -----	1
8	2330001708	活動片 Plate -----	1
9	2330001709	導線座 Thread Guide Holder -----	2
10	2330001710	鬆線板 Release Wedge -----	2
11	2330001711	張力調整螺帽 Tension Nut (Red) -----	12
12	2330001712	套管 Bushing -----	24
13	2330001713	彈簧 Spring -----	12
14	2330001714	彈簧座 Spring Seat -----	24
15	2330001715	羊毛氈 Felt -----	24
16	2330001716	張力控制盤 Tension Disc -----	48
17	2330001717	螺樁 Stud -----	24
18	2330001718	隔環 Spacer -----	24
19	233A0001719	鬆線組 Thread Tension Mechanism (Red) -----	12
20	233A0001720	鬆線組 Thread Tension Mechanism (Blue) -----	12
21	2330001721	張力調整螺帽 Tension Nut (Blue) -----	12
22	2330001722	彈簧 Spring -----	12
23	2330001723	軸 Shaft -----	1
24	2330001724	隔環 Spacer -----	1
25	8MM04281407A	螺絲 Screw (F1003 M4-0.7*14) -----	1
26	2310000341	連桿 Link -----	1
27	2310000342	曲柄 Lever -----	1
28	2310000343	螺樁 Stud -----	1
29	2310000344	螺樁 Stud -----	1
30	8MK95301407A	螺絲 Screw (CT0837 M4.5-0.75*14) -----	1
31	233A0001731	鬆線組 Thread Tension Mechanism -----	2
32	233A0001732	鬆線組 Thread Tension Mechanism -----	1
33	66441-4	貼紙 Paster -----	1

17-1. MT4506 / MT4606 鬆線機構 Tension Stand Mechanism

Subclass / Remark	Date
	2026/03/05

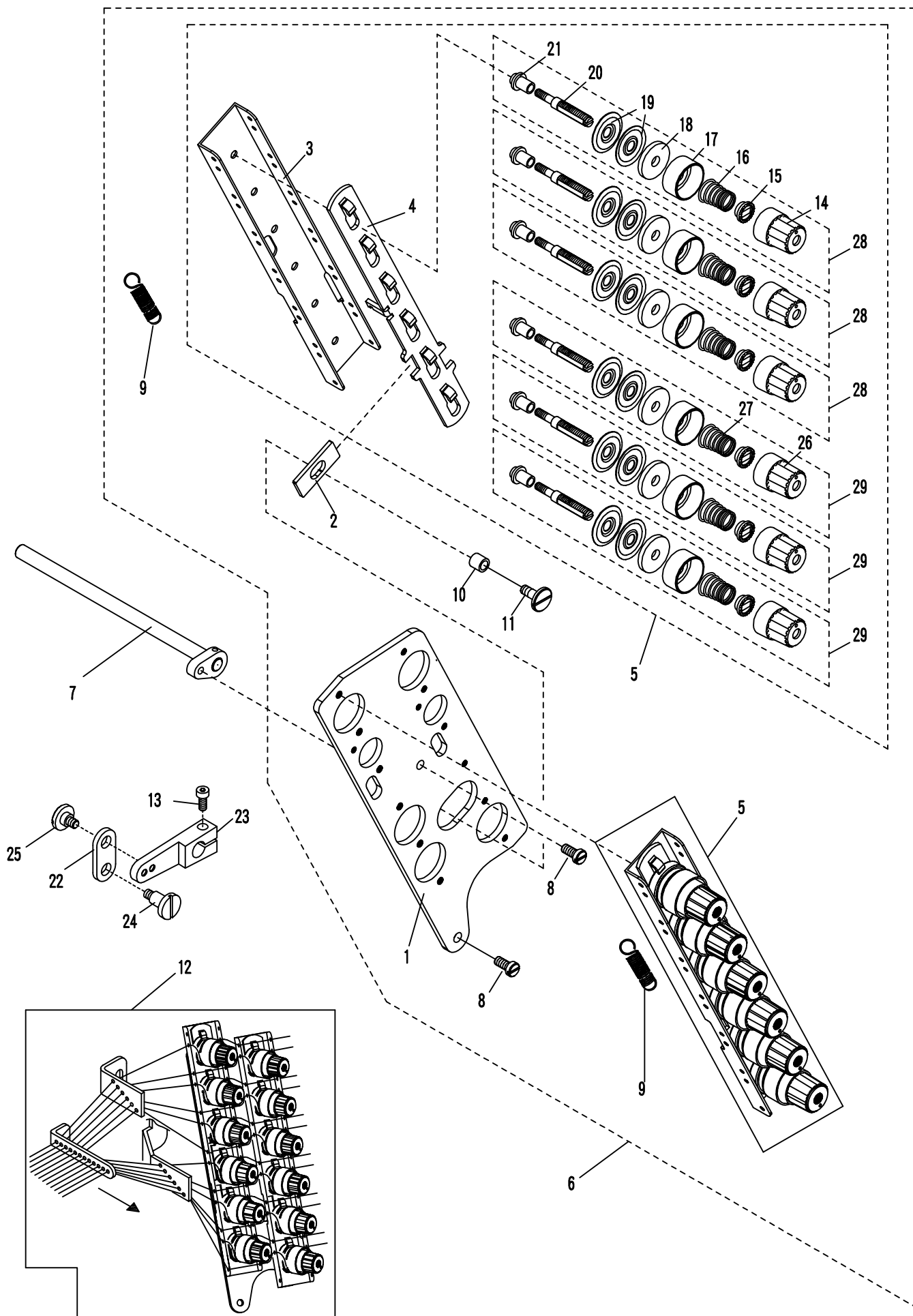

17-1. MT4506 / MT4606 鬆線機構 Tension Stand Mechanism

Subclass / Remark	Date
	2026/03/05

序號 Ref.No.	物料編號 Parts No.	名稱 Description	單位用量 Amt. Req.
1	2320001701	鬆線座 Tension Post Support-----	1
2	2320001702	活動片 Plate -----	1
3	2320001703	導線座 Tension Post Support-----	2
4	2320001704	鬆線板 Release Wedge-----	2
5	231A0001705	鬆線組 Thread Tension Mechanism -----	2
6	231A0001706	鬆線組 Thread Tension Mechanism -----	1
7	2310001905	軸 Shaft -----	1
8	8MC05321208A	螺絲 Screw (M5-0.8*12) (MT0332) -----	2
9	2310000310	彈簧 Spring -----	2
10	2310001910	隔環 Space -----	1
11	2310001911	螺樁 Stud -----	1
12	66441-2	貼紙Paster-----	1
13	8MK95301407A	螺絲 Srew-----	1
14	2100001121	張力調整螺帽 Tension Nut (Red) (See left Page)(SH1121) -----	6
15	2200000303	套管 Bushing (See left Page) (SH1122)-----	12
16	2100001123	彈簧 Spring (Red) (See left Page)(SH1123) -----	6
17	2200000305	彈簧座 Spring Seat (See left Page)(CT0305) -----	12
18	2100001127	羊毛氈 Felt (See left Page)(SH1127) -----	12
19	2100001126	張力控制盤 Tension Disc (See left Page)(SH1126) -----	24
20	22000003081	螺樁 Stud (See left Page) (CT03081)-----	12
21	22000003091	隔環 Spacer (See left Page) (CT03091)-----	12
22	2310000341	連桿 Link-----	1
23	2310000342	曲柄 Lever-----	1
24	2310000343	螺樁 Stud-----	1
25	2310000344	螺樁 Stud-----	1
26	2100001121B	張力調整螺帽 Tension Nut (Bule) (See left Page)(SH1121) -----	6
27	2100001132	彈簧 Spring (Bule)(See left Page)(SH1132) -----	6
28	231A0001922	張力控制組 Tension Set. (Red)-----	6
29	231A0001923	張力控制組 Tension Set. (Bule)-----	6

18. MT4500 / MT4600 定規零件 Gauge Parts

Subclass / Remark	Date
	2026/03/05

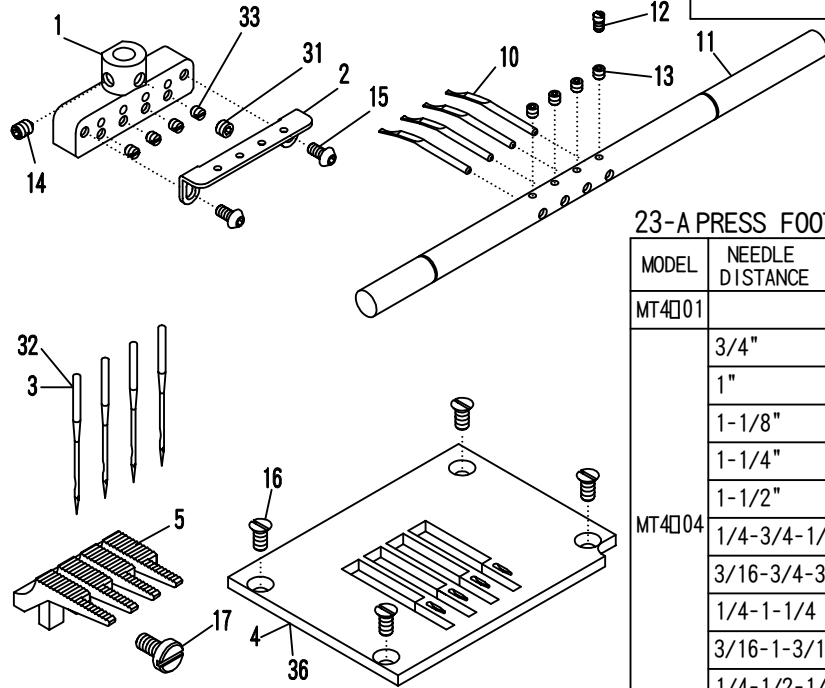
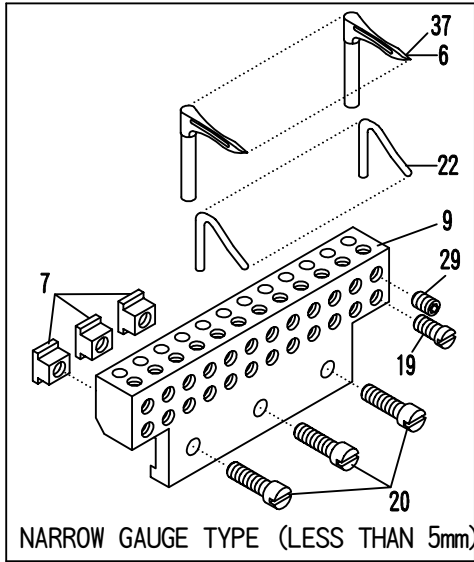

23-A PRESS FOOT

MODEL	NEEDLE DISTANCE	PARTS NO.
MT4□01		5231PF0101A
MT4□04	3/4"	5231PF0401A
	1"	5231PF0403A
	1-1/8"	5231PF0405A
	1-1/4"	5231PF0406A
	1-1/2"	5231PF0408A
	1/4-3/4-1/4	5231PF0411A
	3/16-3/4-3/16	5231PF0412A
	1/4-1-1/4	5231PF0413A
MT4□06	3/16-1-3/16	5231PF0414A
	1/4-1/2-1/4	5231PF0415A
	1/4"	5231PF0601A
	3/8"	5231PF0602A
MT4□09	1/3"	5231PF0603A
	064-119	5231PF0604A
MT4□12	1/4"	5231PF0901A
	3/16"	5231PF1201A
	1/4"	5231PF1202A
MT4□13	5mm	5231PF1203A
	1/4"	5231PF1301A
MT4□17	MULTI-NEEDLE DISTANCE	5231PF1302A
MT4□17	1/8"	5231PF1701A
MT4□25	1/8"	5231PF2501A

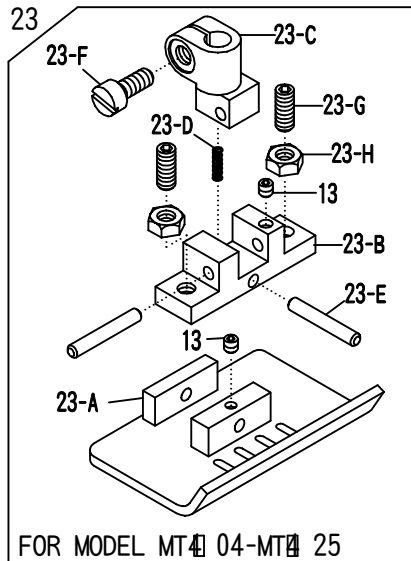
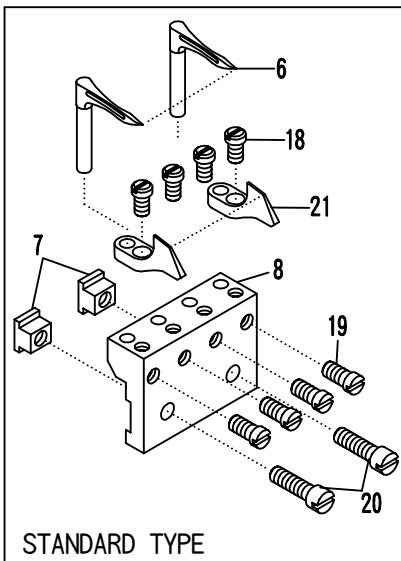
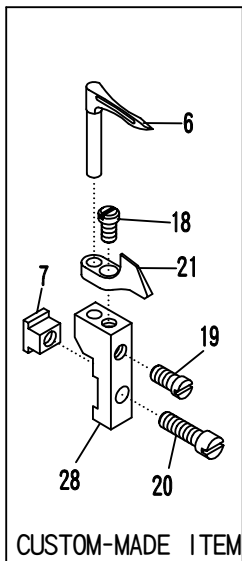

24-A PRESS FOOT

MODEL	NEEDLE DISTANCE	PARTS NO.
MT4□04	3/4"	5231PF0402A
	1"	5231PF0404A
	1-1/8"	5231PF0410A
	1-1/4"	5231PF0407A
	1-1/2"	5231PF0409A

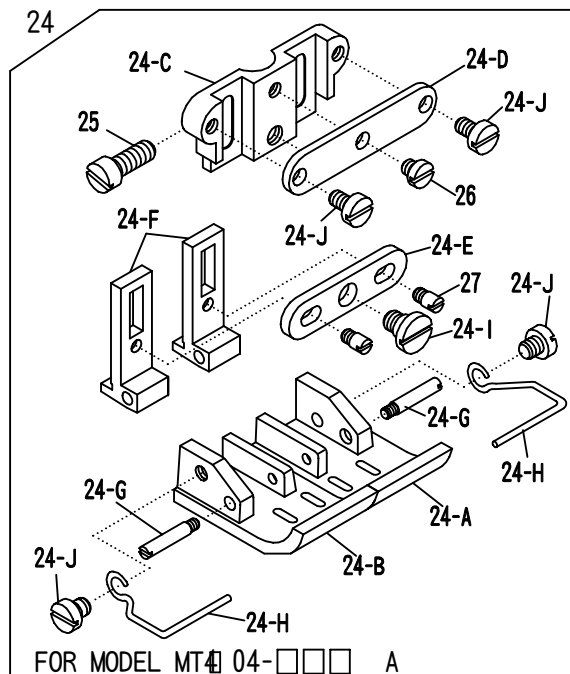
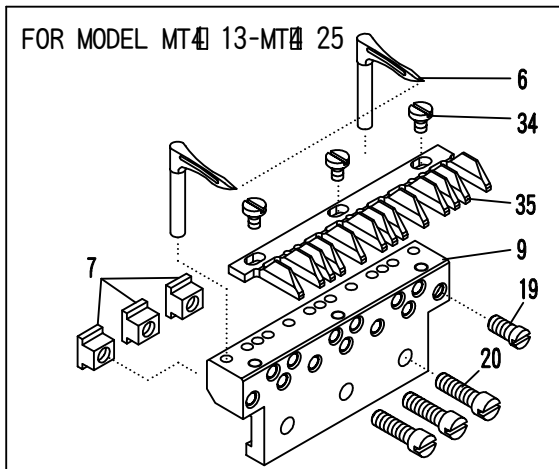
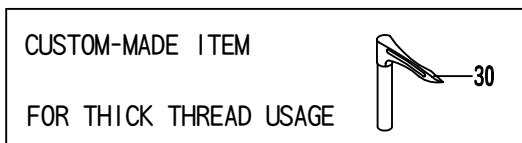

24-B PRESS FOOT

MODEL	NEEDLE DISTANCE	PARTS NO.
MT4□04	3/4"	5231PF0402B
	1"	5231PF0404B
	1-1/8"	5231PF0410B
	1-1/4"	5231PF0407B
	1-1/2"	5231PF0409B

3 NEEDLE REQ.

MODEL NO.	Q' TY	MODEL NO.	Q' TY
MT4□01	1	MT4□04	4
MT4□06	6	MT4□09	9
MT4□12	12	MT4□13	13
MT4□17	17	MT4□25	25

18. MT4500 / MT4600 定規零件 Gauge Parts

Subclass / Remark	Date
	2026/03/05

序號 Ref.No.	物料編號 Parts No.	名稱 Description	單位用量 Amt. Req.
1	-----	針留 Needle Clamp -----	1
2	-----	導線 Thread Guide -----	1
3	66729-14	針 UO113 #14 Needle -----	1
4	-----	針板 Needle Plate -----	1
5	-----	狗齒 Feed Dog -----	1
6	-----	結線鉤 Retainer Lopper -----	-
7	2310001807	承座 Bracker -----	-
8	-----	結線鉤座 Looper Holder -----	1
9	-----	結線鉤座 Looper Holder -----	1
10	5231UL0001	結線鉤 Looper -----	-
11	-----	撥線桿 Retainer Holder -----	1
*12	8MC75180403E	螺絲 Screw (MT1812 M2.5-0.45*3.5) -----	-
13	8MN03200300A	螺絲 Screw (CT0115 M3-0.5*3) -----	-
14	8MN04280400A	螺絲 Screw (CT0229 M4-0.7*4) -----	1
15	8MP03200606A	螺絲 Screw (MT0142 M3-0.5*6) -----	2
16	8SE36400806A	螺絲 Screw (SH0530 9/64"-40*8) -----	4
17	8SC44400909S	螺絲 Screw (MT1817 11/64"-40*6) -----	1
18	8SB32440605A	螺絲 Screw (K07-08 1/8"-44*6) -----	-
19	8SC36400705K	螺絲 Screw (MT1819 9/64"-40*7) -----	-
20	8SB36401205K	螺絲 Screw (MT1820 9/64"-40*12) -----	-
21	5231NG0001	導針器 Needle Guide -----	-
22	5231NG0002	導針器 Needle Guide -----	-
23	-----	壓腳 Presser Foot -----	1
23-A	-----	壓腳底 Presser Foot Guide (See Left Page)-----	1
23-B	5231PF0401B	壓腳連桿 Presser Foot Link -----	1
23-C	5231PF0401C	壓腳柄 Presser Foot Arm -----	1
23-D	5231PF0401D	壓縮彈簧 Spring -----	1
23-E	5231PF0401E	固定銷 Pin -----	1
23-F	8MB04281007K	螺絲 Screw (CT1237 M4-0.7*10) -----	1
23-G	8MN04281000A	螺絲 Screw (CT0216 M4-0.7*10) -----	2
23-H	8MA04280307A	螺帽 Nut (CT0238 M4-0.7*3) -----	2
24	-----	壓腳 Presser Foot -----	1
24-A	-----	壓腳底(右) Presser Foot Guide (Right) (See Left Page)-----	-
24-B	-----	壓腳底(左) Presser Foot Guide (Left) (See Left Page)-----	-
24-C	5231PF0404C	壓腳座 Presser Foot Bracket -----	1
24-D	5231PF0404D	檔片 Plate -----	1
24-E	5231PF0404E	連桿 Link -----	1
24-F	5231PF0404F	滑塊 Bracket -----	2
24-G	5231PF0404G	銷 Pin -----	2
24-H	5231PF0404H	護指環 Safety Plate Holder -----	2
24-I	5231PF0404I	螺絲 Screw (M4.5-0.75*4) -----	1
24-J	8MB85240607K	螺絲 Screw (CT0637 M3.5-0.6*6) -----	4
25	8MB95301107A	螺絲 Screw (CT0706 M4.5-0.75*12) -----	1
26	8MB85240406K	螺絲 Screw (PMD010166 M3.5-0.6*4) -----	1
27	8MB03200304M	螺絲 Screw (MT1827 M3-0.5*3) -----	2
28	2310001828	結線鉤座 Looper Holder -----	1
29	8SN36400400E	螺絲 Screw (SH0222 9/64"-40*4) -----	-
30	5231LL0004	結線鉤 Retainer Lopper (For Thick Thread Usage)-----	1
31	8MN04280500C	螺絲 Screw (FT1222 M4-0.7*5) -----	1
**32	66729-18	針 UO113 #18 Needle -----	1
33	8SH32440300A	螺絲 Screw (S04-65 1/8"-44*2.5) -----	-
*34	8MB03200405A	螺絲 Screw (FT0548 M3-0.5*4) -----	3
*35	-----	導針器 Needle Guide -----	1
**36	5231TP0024	針板 Needle Plate -----	1
**37	5231LL0004	結線鉤 Retainer Lopper -----	1

* For MT4□13-MT4□25 Use.

** For MT4□12 Bigger Eyelet Hole

19. TR02A 擴張滾輪組零件列表 Parts List For TR02A Roller Set

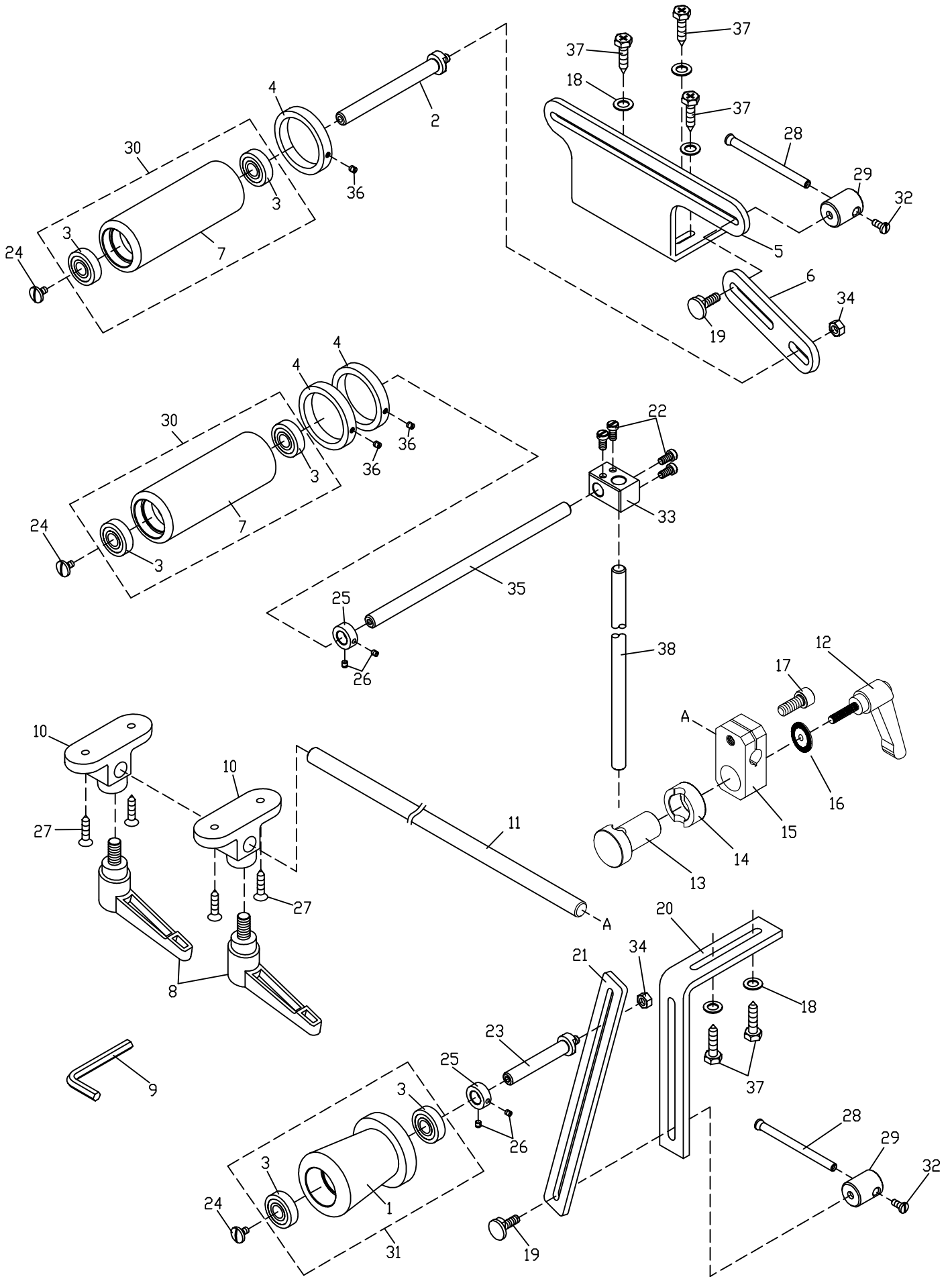

19. TR02A 擴張滾輪組零件列表 Part List For TR02A Roller Set

Subclass / Remark	Date
	2026/03/05

序號 Ref.No	物料編號 Parts No.	名稱 Description	單位用量 A mt.Req.
1	4TR00201011	滾輪 Roller -----	1
2	4TR00201021	軸 Shafe -----	1
3	90BB1026082	滾珠軸承 Ball Bearing -----	6
4	4TR0020104	鬆緊帶導模 Elastic Tape Guide -----	3
5	4TR0020105	滾輪座 Roller Seat -----	1
6	4TR0020106	滾輪臂 Roller Holder Arm -----	1
7	4TR00201071	滾輪 Roller -----	2
8	4TR0020108	固定扳手 Lock Lever -----	2
9	66641	六角扳手 Spanner 6MM -----	1
10	4TR0020110	支架座 Holder Bracket Seat -----	2
11	4TR03A0111	支架 Holder Bracket -----	1
12	4TR03A0112	固定扳手 Lock Lever -----	1
13	4TR03A0113	連接塊 Connecting Block -----	1
14	4TR03A0114	連接塊 Connecting Block -----	1
15	4TR03A0115	連接塊 Connecting Block -----	1
16	4TR03A0116	墊圈 Washing -----	1
17	8MM08502013A	螺絲 Screw (CT0106 M8-1.25*20) -----	1
18	2200000910	墊圈 Washing -----	5
19	4TR0020119	螺椿 Stud -----	2
20	4TR0020120	滾輪臂 Roller Holder Arm -----	1
21	4TR0020121	滾輪臂 Roller Holder Arm -----	1
22	8MB05321008K	螺絲 Screw (CT0233 M5-0.8*10) -----	4
23	4TR0020123	軸 Shafe -----	1
24	8SC44400812A	螺絲 Screw (CL450424 11/64"-40*8) -----	3
25	4TR0020125	定位環 Collar -----	2
26	8MH85240500A	螺絲 Screw (CT0923 M3.5-0.6*5) -----	4
27	8WE37002400A	木螺絲 Wood Screw (CL450427) -----	4
28	4TR0020128	柄 Handle -----	2
29	4TR0020129	止動塊 Tension Roller Slider Stop -----	2
30	4TR002A0130	滾輪組 Roller Asm.-----	2
31	4TR002A0131	滾輪 Roller Asm.-----	1
32	8SC44401008A	螺絲 Screw (SH1225 11/64"-40*10) -----	2
33	2200850421	連接塊 Connecting Block -----	1
34	8MA06400510A	螺帽 Nut (CT0533) -----	2
35	2270850423	支架 Holder Bracket -----	1
36	8MH04280400A	螺絲 Screw (CT1134 M4-0.7*4) -----	3
37	8WK45002900C	木螺絲 Wood Screw (CL450408) -----	5
38	4TR03A0105	支架 Holder Bracker -----	1

註:此裝置僅適用於 MT4004 / MT4504 / MT4604 / MTD4504 / MTD4604 機型

Note:This device is suitable for the model MT4004 / MT4504 / MT4604 / MTD4504 / MTD4604 only.

20. MT4000 / MT4500 / MT4600 / MTD4500 / MTD4600

装載附件 Supporting Board

Subclass / Remark	Date
	2026/03/05

上載式

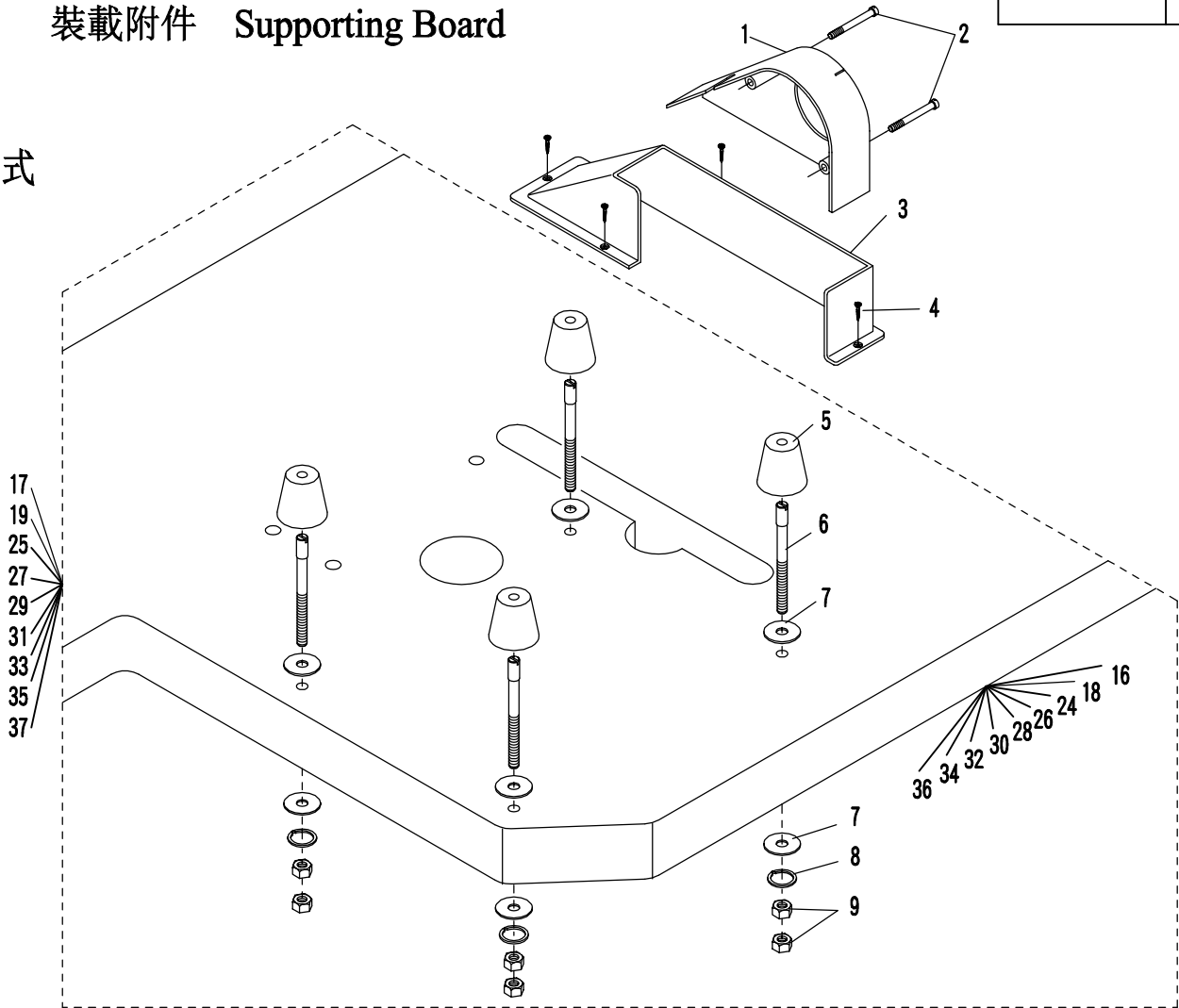

半沉式

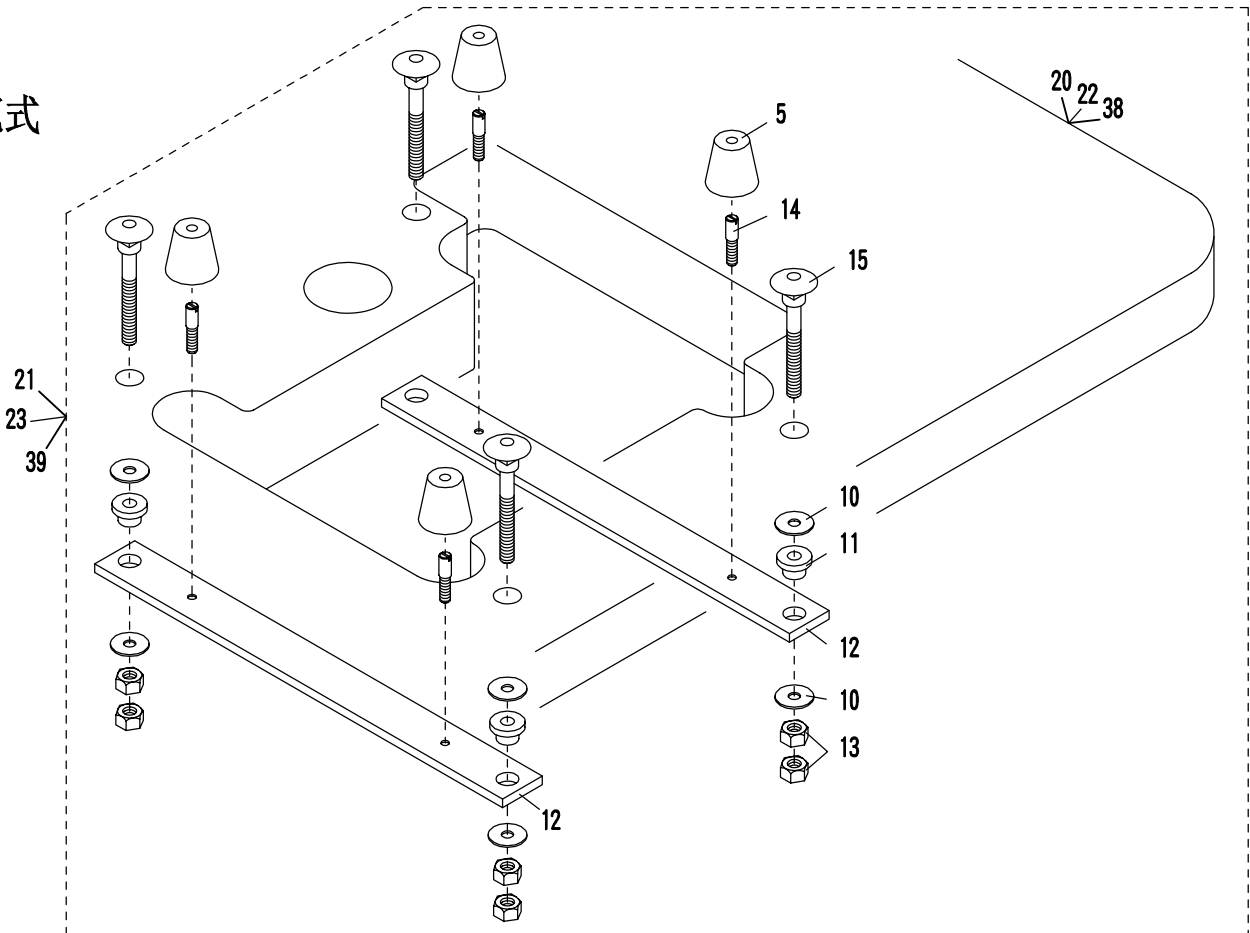

20. MT4000 / MT4500 / MT4600 / MTD4500 / MTD4600

Subclass / Remark	Date
	2026/03/05

裝載附件 Supporting Board

序號 Ref.No.	物料編號 Parts No.	名稱 Description	單位用量 Amt. Req.
1	2310002001	皮帶蓋 Belt Cover -----	1
2	8MB06405609S	螺絲 Screw (M6-1*56) (MT2002) -----	2
3	2310002003	皮帶蓋 Belt Cover -----	1
4	8WF03131706A	木螺絲 Screw (CT1516) -----	4
5	66944	減震橡膠 Rubber Cushion -----	4
6	8MB06406507B	螺椿 Bolt (CT1507 M6-1*65) -----	4
7	2200001504	墊圈 Washer (CT1504) -----	8
8	90SW070	彈簧墊圈 Spring Washer (CT1505) -----	4
9	8MA06400612A	螺帽 Nut (SH0242 M6-1*6) -----	8
10	2200001510	墊圈 Washer -----	8
11	2200001511	橡膠環 Rubber Washer -----	4
12	2310002012	車頭承板 Supporting Board -----	2
13	8SA79180613A	螺帽 Nut (CT1514 5/16"-18*6) -----	8
14	8MB06401607M	螺椿 Stud (CT1503 M6-1*16) -----	4
15	8SC79187827B	懸吊螺椿 Bolt -----	4
●16	66816-2	上載開口式長車板 Open-cut Long Table Top Type (12-25針)-----	-
●17	FS006	上載開口式長車板組 Open-cut Long Table Top Type Asm. (12-25針)-----	-
18	66816-3	上載開口式短車板 Open-cut Short Table Top Type (1-25針)-----	-
19	FS005	上載開口式短車板組 Open-cut Short Table Top Type Asm. (1-25針)-----	-
●20	66816-4	半沉式車板 Semi-Submerged Type (1-25針)-----	-
●21	FS004	半沉式車板組 Semi-Submerged Type Asm.(1-25針)-----	-
●22	66816-5	半沉式車板 Semi-Submerged Type With "PS001"Devic (含PS001) -----	-
●23	FS007	半沉式車板組 Semi-Submerged Type With "PS001"Devic Asm. (含PS001) -----	-
●24	66816-12	上載開口式長車板 (兩用板) Open-cut LongTable Top Type (12-25針)-----	-
●25	FS008	上載開口式長車板組 (兩用板) Open-cut Long Table Top Type Asm. -----	-
●26	66816-13	上載開口式短車板 (兩用板) Open-cut Short Table Top Type (1-25針)-----	-
●27	FS009	上載開口式短車板組 (兩用板) Open-cut Short Table Top Type Asm. -----	-
●28	66816-8	上載式車板 Table Top Type With "MP001+TC" Devic-----	-
●29	FS010	上載式車板 Table Top Type With "MP001+TC" Devic Asm. -----	-
30	66816-9	MTD上載開口式短車板 Open-cut Short Table Top Type -----	-
31	FS011	MTD上載開口式短車板組 Open-cut Short Table Top Type Asm. -----	-
●32	66816-10	MTD上載式短車板 Short Table Top Type -----	-
●33	FS012	MTD上載式短車板組 Short Table Top Type Asm. -----	-
●34	66816-11	MTD上載開口式短車板 (兩用板1200mm) Open-cut Short Table Top Type -----	-
●35	FS013	MTD上載開口式短車板組 (兩用板1200nn) Open-cut Short Table Top Type Asm. -----	-
●36	66816-14	MTD上載開口式車板 (兩用板1000mm) Open-cut Short Table Top Type -----	-
●37	FS014	MTD上載開口式車板組 (兩用板1000mm) Open-cut Short Table Top Type Asm. -----	-
●38	66816-15	MTD半沉式車板 Semi-Submerged Type (1-25針) -----	-
●39	FS015	MTD半沉式車板組 Semi-Submerged Type Asm.(1-25針)-----	-

● 特註品 Custom-made Item

21. MT4500 / MT4600 工具及附件 Accessories

Subclass / Remark	Date
	2026/03/05

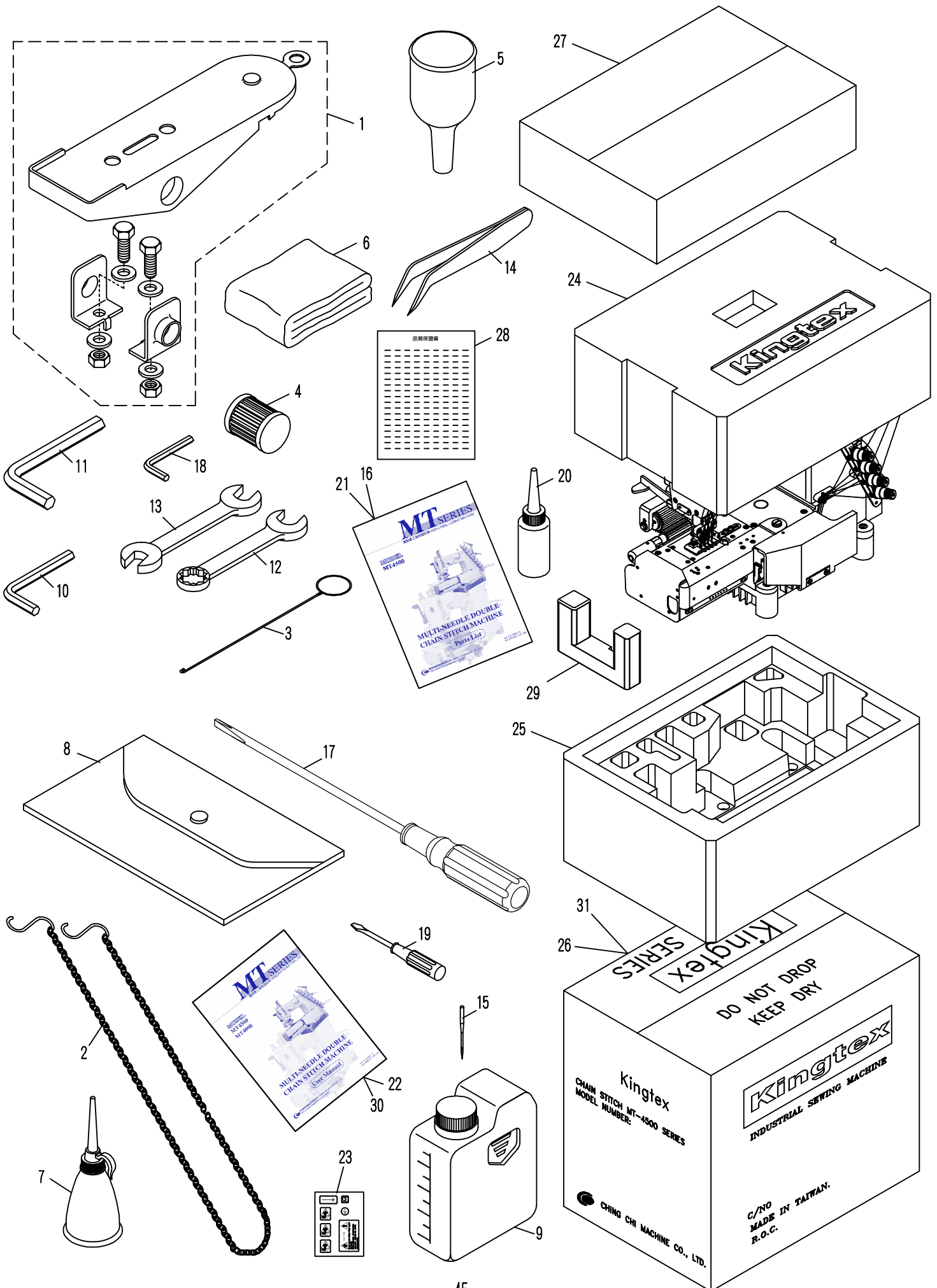

21. MT4500 / MT4600 工具及附件 Accessories

Subclass / Remark	Date
	2026/03/05

序號 Ref.No.	物料編號 Parts No.	名稱 Description	單位用量 Amt. Req.
1	66700	踏板組 Pedel Complete -----	1
2	66695	鍊條組 Chain Set -----	1
3	66840	穿線鋼絲 Threading Bar -----	1
4	2100001521	過濾器 Oil Filter (SH1521)-----	1
5	66722	漏斗 Oil Funnel -----	1
6	66846-2	防塵罩 Mechine Cover -----	1
7	66721	油壺 Oiler -----	1
8	66831	工具袋 Bag (AM-6751)-----	1
9	66715	油罐 Oil Container -----	1
10	66636	六角扳手 Spanner 3MM -----	1
11	66637	六角扳手 Spanner 4MM -----	1
12	66612	梅花扳手 Wrench 10MM -----	1
13	66613	開口扳手 Wrench 7/8MM -----	1
14	66690	鑷子 Tweezer -----	1
15	66729-14-5	備用針 UO113 #12 Retainer Needle -----	1
*16	6MT63O6-H-26-02	零件冊 Parts List -----	1
17	66671	木柄一字起子 Wooden Handle Flat Screw Driver -----	1
18	66639	六角扳手 Spanner 1.5MM (UTB0439) -----	1
19	66667	小起子 Screw Driver (Small) -----	1
20	66720	矽油 Silicon Oil -----	1
21	6MT63O6-1-03-05	零件冊 Parts List -----	1
22	6MT62E6-1-03-05	使用說明書 Instruction Manual -----	1
23	66452	貼紙 Paster -----	1
24	66746-1	保利龍 Styroform -----	1
25	66746-2	保利龍 Styroform -----	1
26	66411	紙箱 Carton -----	1
27	66411-1	附件盒紙箱 Carton -----	1
28	66200	保質保證書 Guarautee -----	1
29	66746-3	保利龍 Styroform -----	1
*30	6MT62M6-3-26-02	使用說明書 Instruction Manual -----	1
*31	66411-4	紙箱 Carton -----	1

* For MT4600 Use.







22. MT4500 / MT4600 GAUGE PARTS LIST

機型 MODEL	針距 GAUGE SIZE (INCH) (針距代碼)	針留 NEEDLE HOLDER	導線 THREAD GUIDE	壓腳組 PRESSER FOOT ASM.	針板 NEEDLE PLATE	送布齒 FEED DOG	結線鉤 LOOPER 座	撥線桿 RETAINER BAR	導針器 NEEDLE GUARD	結線鉤 RETAINER LOOPER	Subclass / Remark	Date	
												2026/03/05	
MT4001		5231NC00241		5231PF0101	5231TP0023	5231FD0023	2310001828				結線鉤 LOOPER		
MT4004	3/4 (064)	5231NC00011	23100022011	5231PF0401	5231TP0001	5231FD0001	2310002221	2310002241	5231NG0001	5231UL0001	5231LL0001		
	1 (085)	5231NC00021		5231PF0402									
	1-1/8 (095)	5231NC00031		5231PF0403	5231TP0002	5231FD0002	2310002222						2310002242
				5231PF0404									
	1-1/4 (106)	5231NC00041	23100022021	5231PF0405	5231TP0003	5231FD0003	2310002223	2310002243					
				5231PF0410									
	1-1/2 (127)	5231NC00051		5231PF0406	5231TP0004	5231FD0004	2310002224	2310002244					
				5231PF0407									
	1/4-3/4-1/4 (064-191)	5231NC00071	23100022041	5231PF0408	5231TP0005	5231FD0005	2310002225	2310002245					
				5231PF0409									
	3/16-3/4-3/16 (048-191)	5231NC00221	23100022021	5231PF0411	5231TP0013	5231FD0013	2310002227	2310002247					
	1/4-1-1/4 (064-254)	5231NC00101	23100022051	5231PF0412	5231TP0014	5231FD0014	2310002226	2310002246					5231NG0002
3/16-1-3/16 (048-254)	5231NC00231	23100022031	5231PF0413	5231TP0015	5231FD0015	2310002230	2310002250	5231NG0001					
1/4-1/2-1/4 (064-127)	5231NC00101	23100022051	5231PF0414	5231TP0016	5231FD0016	2310002234	2310002253						
1/4-1/8 MULTI-NEEDLE DISTANCE	5231NC00121	23100022071	5231PF1302	5231TP0012	5231FD0012	23100022321	2310002252	5231NG0003	5231LL0002				

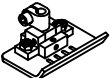
22. MT4500 / MT4600 GAUGE PARTS LIST

機型 MODEL	針距 GAUGE SIZE (INCH) (針距代碼)	針留 NEEDLE HOLDER	導線 THREAD GUIDE	壓腳組 PRESSER FOOT ASM.	針板 NEEDLE PLATE	送布齒 FEED DOG	結線鉤座 LOOPER HOLDER	撥線桿 RETAINER BAR	導針器 NEEDLE GUARD	結線鉤 RETAINER LOOPER	Subclass / Remark	Date		
											結線鉤 LOOPER	2026/03/05		
MT4□06	1/4 (064)	5231NC00091	23100022021	5231PF0601	5231TP0009	5231FD0009	2310002229	2310002249	5231NG0001	5231LL0001				
	3/8 (095)	5231NC00201	23100022051	5231PF0602	5231TP0021	5231FD0021	2310002240	2310002260						
	1/3 (085)	5231NC00211	23100022031	5231PF0603	5231TP0022	5231FD0022	2310002233	2310002261						
	(064-119)	5231NC0026		5231PF0604	5231TP0026	5231FD0026	2310001828	2310002263						
MT4□09	1/4 (064)	5231NC00101	23100022051	5231PF0901	5231TP0010	5231FD0010	2310002230	2310002250	5231UL0001	5231LL0001				
MT4□12	3/16 (048)	5231NC00061	23100022031	5231PF1201	5231TP0027	5231FD0027	2310002226	2310002246					5231NG0002	
	1/4 (064)	5231NC00071	23100022041	5231PF1202	5231TP0007 5231TP0024 BIGGER EYELET HOLE	5231FD0007	2310002227	2310002247					5231NG0001	5231LL0004
	5mm (050)	5231NC00081	23100022031	5231PF1203	5231TP0008	5231FD0008	2310002228	2310002248					5231NG0002	5231LL0001
MT4□13	1/4 (064)	5231NC00111	23100022061	5231PF1301	5231TP0011	5231FD0011	2310002231	2310002251	5231NG0001	5231LL0002				
	MULTI-NEEDLE DISTANCE (064-032)	5231NC00121	23100022071	5231PF1302	5231TP0012	5231FD0012	23100022321	2310002252	5231NG0003					
MT4□17	1/8 (032)	5231NC00191	23100022091	5231PF1701	5231TP0020	5231FD0020	23100022391	2310002259	5231NG0004	5231LL0003				
MT4□25		5231NC0025	2310002210	5231PF2501	5231TP0025	5231FD0025	2310002280	2310002262	5231NG0005					

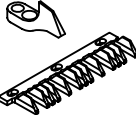
22. MT4500 / UT GAUGE PARTS LIST

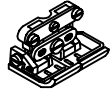
機型 MODEL	針距 GAUGE SIZE (INCH) (針距代碼)	針留 NEEDLE HOLDER	導線 THREAD GUIDE	壓腳組 PRESSER FOOT ASM.	針板 NEEDLE PLATE	送布齒 FEED DOG	結線鉤座 LOOPER HOLDER	撥線桿 RETAINER BAR	導針器 NEEDLE GUARD	結線鉤 RETAINER LOOPER	結線鉤 LOOPER										
MT4504 /UT04A	3/4 (064)	5231NC00011		 5231PF0401																	
				5231PF0402								5231TP001T	5231FD0001	2310002221	2310002241						
MT4504 /UT04B	1 (085)	5231NC00021		23100022011	 5231PF0403	5231TP002T	5231FD0002	2310002222				2310002242	5231NG0001	5231UL0001	5231LL0006						
				5231PF0404	5231TP003T											5231FD0003	2310002223	2310002243			
MT4504 /UT04C	1-1/8 (095)	5231NC00031		5231PF0405	5231TP005T	5231FD0005	2310002225	2310002245				5231NG0001				5231UL0001	5231LL0006				
				5231PF0410														5231PF0408	5231PF0409	5231TP015T	5231FD0015
MT4504 /UT04S	1-1/2 (127)	5231NC00051		23100022021	5231PF0413	5231TP015T	5231FD0015	2310002230										2310002250	5231NG0001	5231UL0001	5231LL0006
MT4504 /UT04S1	1/4-1-1/4 (064-254)	5231NC00101		23100022051	5231PF0601	5231TP009T	5231FD0009	2310002229										2310002249			
MT4506 /UT06A	1/4 (064)	5231NC00091		23100022021	5231PF0901	5231TP010T	5231FD0010	2310002230										2310002250			
MT4509 /UT09A		5231NC00101		23100022051	5231PF1202	5231TP007T	5231FD0007	2310002227										2310002247			
MT4512 /UT12A	1/4 (064)	5231NC00071	23100022041	5231PF1701	5231TP020T	5231FD0020	23100022391	2310002259	5231NG0004	5231LL0005											
MT4517 /UT17S	1/8 (032)	5231NC00191	23100022091																		

22. MT4500 / MT4600 / UT□□□-P□ GAUGE PARTS LIST

機型 MODEL	針距 GAUGE SIZE (INCH) (針距代碼)	針留 NEEDLE HOLDER	導線 THREAD GUIDE	壓腳組 PRESSER FOOT ASM.	針板 NEEDLE PLATE	送布齒 FEED DOG	結線鉤座 LOOPER 座 HOLDER	撥線桿 RETAINER BAR	導針器 NEEDLE GUARD	結線鉤 RETAINER LOOPER	結線鉤 LOOPER
MT4604 /UT04B-P	1 (085)	5231NC0021	23100022011	5231PF0403	5231TP002P	5231FD0002	2310002222	2310002242	5231NG0001	5231UL0001	5231LL0006
MT4604 /UT04B-P1				5231PF0404							
MT4612 /UT12A-P	1/4 (064)	5231NC00071	23100022041	5231PF1202	5231TP007P	5231FD0007	2310002227	2310002247	5231NG0001	5231UL0001	5231LL0005
MT4612 /UT12A-P1											
MT4625 /UT25S-P	1/8 (032)	5231NC0025	2310002210	5231PF2501	5231TP025P	5231FD0025	2310002280	2310002262	5231NG0005	5231UL0001	5231LL0005
MT4625 /UT25S-P1											



NTD7001
4-Needle, 6-Thread Flat-Seamer,
Feed-Off-The-Arm Machine



MT4506P-064
6-Needle Double Chain Stitch Machine



UHU9304/TR025
Automatic chain cutter device direct-drive
cylinder bed top feed overlock fitted with
labor-saving rib folder



CXM2085-0-356M
Attaching Pre-Closed Flat Knit Elastic Band
Onto Waists Of Tubular Goods
(With Right Knife, Rear Puller & Chips Suction Pipe)



精機機械廠股份有限公司
CHING CHI MACHINE CO., LTD.

The specification and / or appearances of the equipment described
in this catalogue are subject to be changed without prior notice.

本目錄所述產品，因更新或改良，可能不事前預告，而對產品之外觀、規格、內容有所修改，特此聲明敬告請鑒亮。

