

# 1. PFE06 電磁式壓腳提昇裝置 Elec-Magnetic Presser Foot Lifter

Subclass / Remark	Date
	2026/02/05

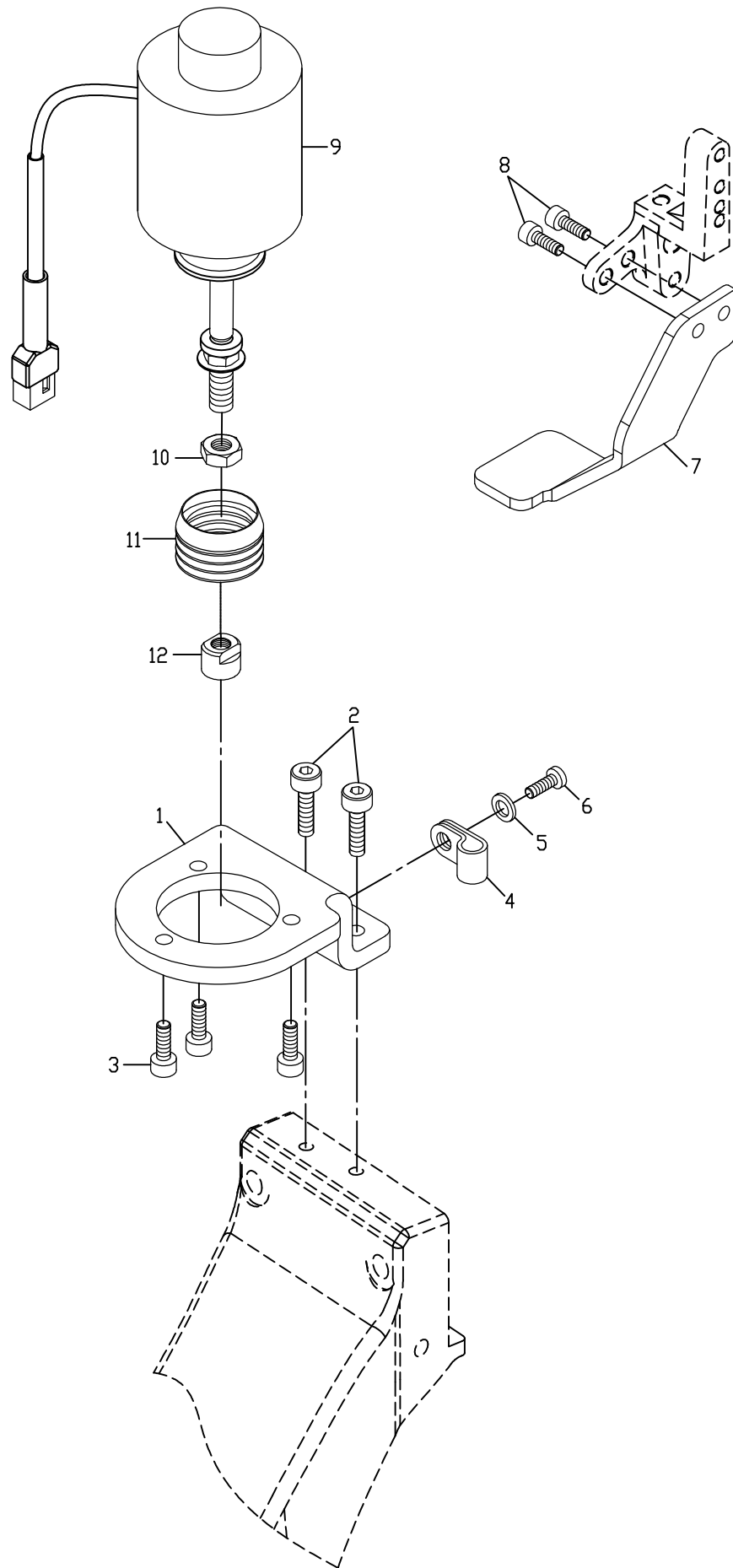

# 1. PFE06電磁式壓腳提昇裝置 Elec-Maghetic Presser Foot Lifter

序號 Ref.No.	物料編號 Parts No.	名稱 Description	單位用量 Amt.Req.
1	4PFE0601031	支架 Bracket-----	1
2	8MM06401610X	螺絲 Screw-----	2
3	8MM05321409X	螺絲 Screw-----	3
4	4PFE040103	管夾 Thread Pipe Stay-----	1
5	2100000223	墊圈 Washer-----	1
6	8MC04280807D	螺絲 Screw-----	1
7	4PFE0601021	壓桿 Bracket-----	1
8	8MM05321009X	螺絲 Screw-----	2
9	4PFE06A0105	磁力線圈組 Presser Foot Lifter Solenoid Asm.-----	1
10	8MA08500413A	螺帽 Nut-----	1
11	4PFE050107	橡膠套 Cap-----	1
12	4PFE060104	接頭 Clutch Sleeve-----	1